



Technical catalog - Preliminary

SACE Tmax XT UL/CSA

New low voltage molded case
circuit breakers up to 250A for UL 489
and CSA C22.2 Standards



[Construction characteristics](#)

1

[The SACE Tmax XT ranges](#)

2

[Accessories](#)

3

[Characteristic curves and technical information](#)

4

[Overall dimensions](#)

5

[Wiring diagrams](#)

6

[Ordering codes](#)

7

New SACE Tmax XT. Simply XTraordinary.



ABB SACE is proud to present the result of a long and intense research and development project: the new SACE Tmax XT up to 250A - ABB SACE's new family of molded case circuit breakers.



Today a highly advanced range of circuit breakers has been introduced, with unparalleled versatility of use and the ability to solve all installation problems brilliantly. You can find the new SACE Tmax XT in three-pole and four-pole, fixed, plug-in and withdrawable versions. They are fitted with the very latest generation thermomagnetic and electronic trip units, with the possibility of interchangeability. The new SACE Tmax XT sets a new technological standard and

provides the freedom to build installations with extraordinary performances. An extraordinary demonstration of ABB SACE's innovation capability. Extraordinary latest generation electronics. Extraordinary coverage of all plant requirements. Extraordinary performances in compact dimensions. Extraordinary simplicity of installation and putting into service. Extraordinary range of accessories available.

[New SACE Tmax XT. Simply XTraordinary.](#)

New SACE Tmax XT. XTraordinary completeness of range.



There are the 4 new SACE Tmax XT UL/CSA frames:

- small XT1 up to 125A
- high-performing XT2 up to 125A
- reliable XT3 up to 225A
- powerful XT4 up to 250A



The new SACE Tmax XT go everywhere and fear no tests because they are made to respond successfully to all plant engineering requirements, from the standard to the most technologically advanced, thanks to the extraordinary fullness of their range. They provide a complete offering up to 250A for distribution, for energy metering, for motor protection, for generator protection, as switch-disconnectors and for any other needs. In addition, a new range of both thermomagnetic and electronic protection trip units, interchangeable right from

the smallest frames, has been created. This is to say nothing of the new and vast line of dedicated accessories available, even for special applications.

All that remains is making a simple selection: XT1 and XT3, with ABB SACE's unquestioned reliability and safety, for standard installations, or XT2 and XT4, with top of the market performance, for technologically advanced installations. The new SACE Tmax XT: simply extraordinary, for any choice.

[New SACE Tmax XT. XTreme protection.](#)

New SACE Tmax XT. XTraordinary advanced electronics.



Welcome a totally renewed, high-performing and versatile range of electronic trip units.

Ekip: the new, very latest generation electronic trip units which equip the new frames of SACE Tmax XT2 and SACE Tmax XT4 circuit breakers.



Ekip trip units are interchangeable and guarantee absolute tripping reliability and precision. Apart from the continuous green LED, which indicates correct operation of the protection trip unit, all the Ekip trip units also have an LED to signal intervention of all the protection functions.

To allow the Ekip units to communicate and exchange information with the other devices, the Ekip Com module can be inserted inside the circuit breaker, freeing space inside the electric panel.

All the Ekip trip units can be fitted with a vast range of dedicated accessories. The main accessories include:

- the Ekip Display, to be applied onto the front of the electronic trip unit for simpler setting and for better reading of information;
- the Ekip LED Meter, a device to be installed on the front of the trip unit to simplify current readings;
- the Ekip TT, the new trip test unit;
- the Ekip T&P, the extraordinary testing and programming unit.

Finally, for the first time an integrated energy metering function is available on the 250A frame Ekip: isn't all this simply XTraordinary?

[New SACE Tmax XT. XTended technology.](#)

Construction characteristics

Construction characteristics	1/2
Regulations and reference standards	1/5
Identification of the SACE Tmax XT circuit breakers	1/6
Nomenclature of the trip units	1/7

Construction characteristics

1

Molded case circuit breakers (MCCB)

			XT1		
Frame Size		[A]	125		
Rated		80% rated	■		
		100% rated TM	up to 100A		
		100% rated Ekip	-		
Poles		[No.]	3, 4		
Rated voltage	(AC) 50-60Hz	[V]	600Y/347		
	(DC)	[V]	500		
Versions			Fixed, Plug-in		
Interrupting ratings			N	S	H
	240 V (AC)	[kA]	50	65	100
	480 V (AC)	[kA]	25	35	65
	600Y/347 V (AC)	[kA]	18	22	25
	600 V (AC)	[kA]	-	-	-
	250 V (DC) 2 poles in series	[kA]	35	42	50
	500 V (DC) 3 poles in series	[kA]	-	-	-
	500 V (DC) 4 poles in series	[kA]	35	50	50
	600 V (DC) 3 poles in series	[kA]	-	-	-
Mechanical life		[No. Operations]	25000		
		[No. Hourly operations]	240		
Dimensions - Fixed (Width x Depth x Height)	3 poles	[mm]/[in]	[76,2 x 70 x 130] / [3 x 2.75 x 5.12]		
	4 poles	[mm]/[in]	[101,6 x 70 x 130] / [4 x 2.75 x 5.12]		
Weight	Fixed 3/4 poles	[kg]/[lbs]	[1,1 - 2.43] / [1,4 - 3,07]		
	Plug-in (EF) 3/4 poles	[kg]/[lbs]	[2,21 - 4.87] / [2,82 - 6.22]		
	Withdrawable (EF) 3/4 poles	[kg]/[lbs]	-		
Total opening time	CB with SOR	[ms]	15		
	CB with UVR	[ms]	15		
Trip units for power distribution					
	TMF		■		
	TMA				
	Ekip LS/I				
	Ekip I				
	Ekip LSI				
	Ekip LSIG				
	Ekip E-LSIG				
Interchangeable protection trip units					

⁽¹⁾ Current Limiting circuit breaker in 480V AC and 600V AC

⁽²⁾ 2-poles version available only as complete circuit breaker with TMF, trip units interchangeable; 4-poles version available only as complete circuit breaker from In=80 to In=250 with TMF, trip units interchangeable

⁽³⁾ With F, EF, ES, FCCuAI installation

⁽⁴⁾ 100kA up to 150A, 65kA from 175A up to 250A

Motor protection ⁽¹⁾

			XT1		
Frame Size		[A]	125		
Poles		[No.]	3		
Rated service voltage	(AC) 50-60Hz	[V]	600Y/347		
	(DC)	[V]	500		
Versions			Fixed, Plug-in		
Rating level			H		
Trip units for motor protection					
	MA (MCP)		■		
	Ekip M-LIU (MPCB)				

⁽¹⁾ Available only as complete circuit breaker

Molded case disconnect switches (MCS)

			XT1		
Frame Size		[A]	125		
Poles		[No.]	3, 4		
Rated voltage	(AC) 50-60Hz	[V]	600Y/347		
	(DC)	[V]	500 4p series / 3p CB up to 250V DC 2p series		
Versions			Fixed, Plug-in		
Rating level			N	S	H
Magnetic Override		[A]	1250		

XT2						XT3		XT4					
125						225		250					
■						■		■					
up to 100A						fixed version only		up to 250A ⁽³⁾					
■						-		up to 250A ⁽³⁾					
3, 4						3, 4		2 (for N version) 3, 4					
600						600Y/347		600					
500						500		600					
Fixed, Plug-in, Withdrawable						Fixed, Plug-in		Fixed, Plug-in, Withdrawable					
N	S	H ⁽¹⁾	L ⁽¹⁾	V ⁽¹⁾	X	N	S	N	S	H ⁽¹⁾	L ⁽¹⁾	V ⁽¹⁾	X
65	100	150	200	200	200	50	65	65	100	150	200	200	200
25	35	65	100	150	200	25	35	25	35	65	100	150	200
-	-	-	-	-	-	10	10	-	-	-	-	-	-
18	22	25	35	42	45	-	-	18	22	25	50	65	100/65 ⁽⁴⁾
35	50	65	75	85	85	25	35	35	42	50	85	100	-
35	50	65	75	85	85	25	35	-	-	-	-	-	-
-	-	-	-	-	-	-	-	-	-	-	-	-	-
-	-	-	-	-	-	-	-	35	50	65	75	85	-
25000						25000		25000					
240						240		240					
[90 x 82,5 x 130] / [3,54 x 3,25 x 5,12]						[105 x 70 x 150] / [4,13 x 2,75 x 5,90]		[105 x 82,5 x 160] - [4,13 x 3,25 x 6,3]					
[120 x 82,5 x 130] / [4,72 x 3,25 x 5,12]						[140 x 70 x 150] / [5,51 x 2,75 x 5,90]		[140 x 82,5 x 160] - [5,51 x 3,25 x 6,3]					
[1,2 - 2,65] / [1,6 - 3,53]						[1,7 - 3,37] / [2,1 - 4,63]		[2,5 - 5,51] / [3,5 - 7,72]					
[2,54 - 5,60] / [3,27 - 7,21]						[3,24 - 7,14] / [4,1 - 9,04]		[4,19 - 9,24] / [5,52 - 12,17]					
[3,32 - 7,32] / [4,04 - 8,91]								[5 - 11,02] / [6,76 - 14,90]					
15						15		15					
15						15		15					
■						■		■					
■						■		■					
■						■		■					
■						■		■					
■						■		■					
■						■		■					
■						■		■					

XT2						XT3		XT4					
125						225		250					
3						3		3					
600						600Y/347		600					
500						500		600					
Fixed, Plug-in, Withdrawable						Fixed, Plug-in		Fixed, Plug-in, Withdrawable					
H						S		H					
■						■		■					
■						■		■					

XT2						XT3		XT4					
125						225		250					
3, 4						3, 4		3, 4					
600						600Y/347		600					
500 3p series						500 3p series		600 3p series					
Fixed, Plug-in, Withdrawable						Fixed, Plug-in		Fixed, Plug-in, Withdrawable					
N	H		L	V		N	S	N	S	H		L	V
1250						2250		2500					

Construction characteristics

1



Positive operation

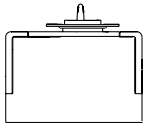
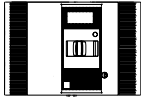
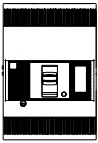

Installation positions

The references in round brackets ^(Gx.x) refer to the Glossary in the final chapter of the technical catalog.

All circuit breakers in the SACE Tmax XT family are made with the following construction characteristics:

- double insulation^(G1.5);
- positive operation^(G1.6);
- isolation behavior^(G1.7);
- electromagnetic compatibility^(G1.8);
- tropicalization^(G1.9);
- impact and vibration resistance^(G1.10);
- power supply from the top towards the bottom or vice versa, except for over 480V on XT2 and over 600V on XT4;
- installation versatility. Circuit breaker can be mounted in a horizontal or vertical position or laid flat without any derating of rated characteristics;
- no nominal performance derating for use up to an altitude of 2000m/6561ft. Above 2000m/6561ft, atmospheric properties (air composition, dielectric strength, cooling power and pressure) change, affecting the main parameters that define the circuit breaker. The table below shows changes to the main performance parameters:

Altitude		2000m/ 6561ft	3000m/ 9842ft	4000m/ 13123ft	5000m/ 16404ft
Rated employ voltage, U _e	[V AC]	600	528	468	408
Rated uninterrupted current	%	100	98	93	90

- SACE Tmax XT circuit breakers can be used in ambient temperatures between -25°C/-13°F and +70°C/158°F and stored in ambient temperatures between -40°C/-40°F and +70°C/158°F. For temperatures outside these ranges, see the “Temperature performance” paragraph of the “Typical curves and technical information” chapter;
- different degrees of IP (International Protection)^(G 1.11);

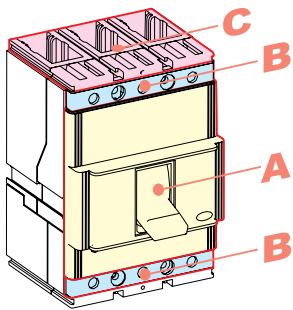

1SD0210A01P0001

Protection degrees

Circuit-breaker

	With front	Without front ⁽¹⁾	With front for lever -FLD-	With rotary handles	With extended rotary handle and accessory IP54	With high terminal covers HTC	With low terminal covers LTC
A	IP40	IP20	IP40	IP40	IP54	IP40	IP40
B	IP20	IP20	IP20	IP20	IP20	IP40	IP40
C	NC	NC	NC	NC	NC	IP40	IP30

⁽¹⁾ During the installation of electrical accessories
NC Not classifiable

Accessories

	Motor operator MOD, MOE or MOE-E	Residual current devices	Residual current from switchboard RCQ020	Automatic transfer switch ATS021 and ATS022
On Front	IP30	IP40	IP41	IP40

- all circuit breakers in the XT family have a pushbutton for performing the release test. The circuit breaker must be closed, with no current, while the test is being performed.



Test pushbutton

Regulations and reference standards



Hologram



Naval Registers

Conformity with Standards

SACE Tmax XT circuit breakers and their accessories are constructed in conformity with:

- Standard^(G6.1):
 - UL 489;
 - CSA C22.2 No. 5;
 - IEC 60947-2;
- Directives^(G6.2):
 - EC “Low Voltage Directive” (LVD) N° 2006/95/EC (replacing 73/23/EEC and subsequent amendments);
 - EC “Electromagnetic Compatibility Directive” (EMC) 2004/108/CE;
- Naval Registers^(G6.3) (ask ABB SACE for the versions available):
 - ABS.

Certification of conformity with the product Standards is carried out in the ABB SACE test laboratory (accredited by SINAL) in respect of the EN 45011 European Standard, by the Italian certification body ACAE (Association for Certification of Electrical Apparatus), member of the European LOVAG organization (Low Voltage Agreement Group) and by the Swedish certification body SEMKO belonging to the International IECEE organization.

The SACE Tmax XT series has a hologram on the front, obtained using special anti-forgery techniques. This ensures the quality and authenticity of the circuit breaker as a genuine ABB SACE product.

Company Quality System

The ABB SACE Quality System conforms to the following Standards:

- ISO 9001 International Standard;
- EN ISO 9001 (equivalent) European Standards;
- UNI EN ISO 9001 (equivalent) Italian Standards;
- IRIS International Railway Industry Standard.

The ABB SACE Quality System attained its first certification with the RINA certification body in 1990.

Environmental management system, social responsibility and ethics

For ABB SACE, environmental protection is a top priority, as evidenced when ours was the first industry in Italy’s electromechanical sector to have obtained the RINA’s Environmental Management System certification in recognition of the company’s commitment in conformity with the International ISO 14001 Standard.

In 1999, the Environmental Management System and the Occupational Health and Safety Management System were integrated according to the OHSAS 18001 Standard. In 2005, the SA 8000 (Social Accountability 8000) Standard was integrated, committing itself to respect business ethics and working conditions.

Our commitment to environmental protection is solidified through:

- selection of materials, processes and packaging which mitigate the true environmental impact of the product;
- use of recyclable materials;
- voluntary adherence to the RoHS directive^(G6.4).

ISO 14001, 18001 and SA8000 recognitions together with ISO 9001 made it possible for ABB SACE to obtain RINA BEST FOUR CERTIFICATION.

Identification of the SACE Tmax XT circuit breakers

1

The specifications of each circuit breaker appear on the rating name plate on both the front and side of the unit.

Front label

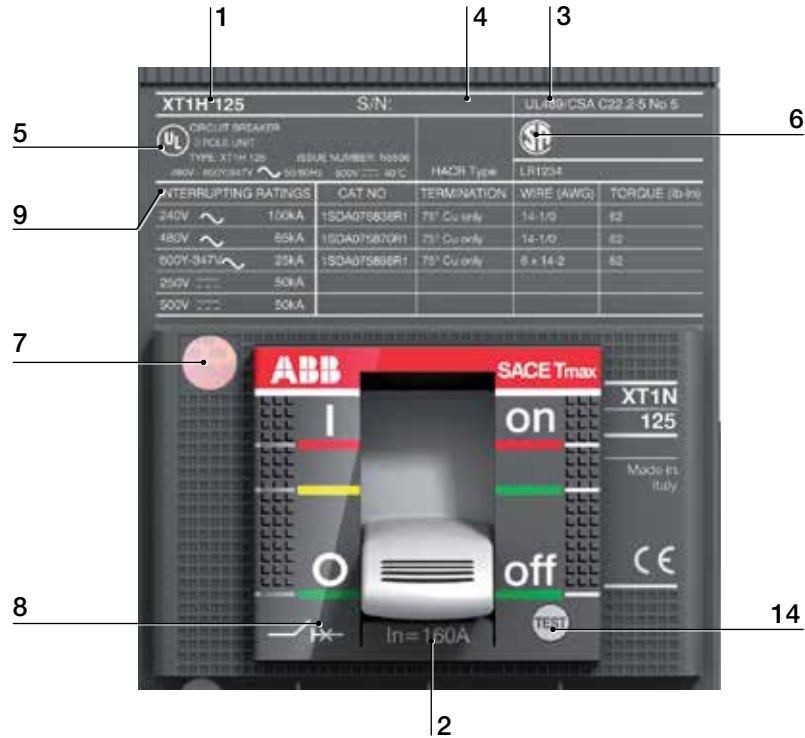

Side label

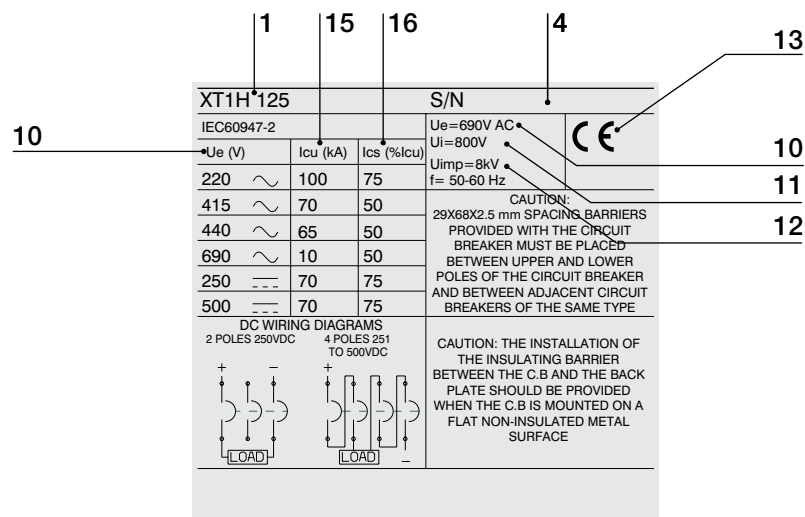

- | | | | |
|---|----------------------------------|----|--|
| 1 | Name and performance level | 9 | Interrupting ratings |
| 2 | In: rated current | 10 | Rated service voltage |
| 3 | Reference standard UL489/CSA22.2 | 11 | Rated insulation voltage |
| 4 | Serial number | 12 | Rated impulse withstand voltage |
| 5 | UL marking | 13 | CE marking |
| 6 | CSA marking | 14 | Test pushbutton |
| 7 | Anti-forgery logo | 15 | Rated ultimate short-circuit breaking capacity |
| 8 | Symbol of isolation behavior | 16 | Rated short-circuit duty breaking capacity |

Nomenclature of the trip units

The tables below outline the logic behind the naming of each thermomagnetic and electronic trip unit.

Magnetic trip units		
Family name		Protection
M: magnetic	+	A: with adjustable threshold

Thermomagnetic trip units		
Family name		Protection
TM: thermomagnetic	+	F: with fixed threshold A: with adjustable thermal and magnetic threshold

Example:

- MA: magnetic only trip unit, with adjustable protection threshold (MCP);
- TMF: thermomagnetic trip unit, with fixed thermal and fixed magnetic protection threshold;

Electronic trip units				
Family name		Application	Protection	
Ekip	+	...: Distribution M: Motor protection E: Energy measurements	+	I LS/I LSI LSIG LIU

Example:

- Ekip LS/I: electronic trip unit for distribution networks protection, with “L” against overload and either “S” protection function against delay short circuit or “I” protection function against instantaneous short circuit;
- Ekip M-LIU: electronic trip unit for motor protection, with LIU protection functions.

Residual current protection devices		
Family name		Typology
RC	+	Inst: instantaneous type 'A' Sel: selective type 'A' Sel 200: selective type 'A' reduced to 200mm B Type: selective type 'B'

The SACE Tmax XT ranges

[The SACE Tmax XT family ranges](#) 2/2

[Circuit breakers for power distribution](#)

Main characteristics	2/3
Thermomagnetic trip units	2/4
Electronic trip units	2/6

[Circuit breakers for motor protection](#)

Main characteristics	2/13
Magnetic trip units	2/14
Electronic trip units	2/15

[Molded case switch disconnectors](#)

Main characteristics	2/16
----------------------	------

[Current Limiting](#)

Electrical characteristics	2/17
----------------------------	------

[Special applications](#)

Communication system	2/18
----------------------	------

The SACE Tmax XT family ranges

The SACE Tmax XT molded case circuit breaker family for UL/CSA complies with different installation requirements. Circuit breakers are available with trip units dedicated to different applications, such as power distribution and motor protection. Molded case switch disconnectors are also available.

2

In = Rated uninterrupted current ^(G2.2) [A]	XT1 125	XT2 125	XT3 225	XT4 250
Power distribution				
Thermomagnetic trip units				
TMF	15...125	15...70	60...225	25...250
TMA		80...125		80...250
Electronic trip units				
Ekip LS/I		10...125		40...250
Ekip I		10...125		40...250
Ekip LSI		10...125		40...250
Ekip LSIG		10...125		40...250
Ekip E-LSIG				40...250
Motor protection				
Magnetic trip units				
MA (MCP)	3...125	3...125	100...200	25...250
Electronic trip units				
Ekip M-LIU (MPCB)		25...100		40...150
Molded case switch disconnectors				
Standard	■	■	■	■
Special applications				
Communication		■		■

Circuit breakers for power distribution

Main characteristics

SACE Tmax XT moulded case circuit breakers are the ideal solution for all distribution levels, from the main low voltage switchboard to panelboards throughout the installation. They feature high specific let-through current peak and energy-limiting characteristics that allow the circuits and equipment on the load side to be sized optimally. SACE Tmax XT circuit breakers with thermomagnetic and electronic trip units protect against overloads, short-circuits, ground faults and indirect contacts in low voltage distribution networks.

The SACE Tmax XT family of moulded case circuit breakers can be equipped with:

- thermomagnetic trip units^(G3.2), for direct and alternating current network protection, using the physical properties of a bimetal and an electromagnet to detect overloads and short-circuits;
- electronic trip units^(G3.4), for alternating current network protection. Releases with microprocessor technology obtain protection functions that make the operations extremely reliable and accurate. The power required for operating them is supplied straight from the current sensors of the releases. This ensures they trip even in single-phase conditions at the minimum setting. The electronic protection trip unit consists of:
 - 3 or 4 current sensors (current transformers);
 - a protection unit;
 - an opening solenoid (built into the electronic trip unit).

Characteristics of SACE Tmax XT Ekip Electronic trip units	
Operating temperature	-25°C/-13°F...+70°C/+158°F
Relative humidity	98%
Self-supplied	0.2xIn (single phase) ⁽¹⁾
Auxiliary supply (where applicable)	24V DC ± 20%
Operating frequency	45...66Hz or 360...440Hz
Electromagnetic compatibility	IEC 60947-2 Annex F

⁽¹⁾ For 10A: 0.4In

Characteristics of circuit breakers for power distribution

		XT1	XT2	XT3	XT4
Size^(G2.1)	[A]	125	125	225	250
Poles	[No.]	3, 4	3, 4	3, 4	2 ⁽¹⁾ , 3, 4,
Rated service voltage, Ue^(G2.4)	(AC) 50-60Hz [V]	600Y/347	600	600Y/347	600
	(DC) [V]	500	500	500	600
Versions		Fixed, Plug-in	Fixed, Plug-in, Withdrawable	Fixed, Plug-in	Fixed, Plug-in, Withdrawable
Breaking capacities		N S H	N S H⁽²⁾ L⁽²⁾ V⁽²⁾ X	N S	N S H⁽²⁾ L⁽²⁾ V⁽²⁾ X
Trip units		Thermomagnetic	Thermomagnetic, Electronic	Thermomagnetic	Thermomagnetic, Electronic
TMF	[In A]	15, 20, 25, 30, 35, 40, 45, 50, 60, 70, 80, 90, 100, 110, 125	15, 20, 25, 30, 35, 40, 50, 60, 70	60, 70, 80, 90, 100, 110, 125, 150, 175, 200, 225	25, 30, 35, 40, 50, 60, 70, 80 ⁽³⁾ , 90 ⁽³⁾ , 100 ⁽³⁾ , 110 ⁽³⁾ , 125 ⁽³⁾ , 150 ⁽³⁾ , 175 ⁽³⁾ , 200 ⁽³⁾ , 225 ⁽³⁾ , 250 ⁽³⁾
TMA	[In A]	–	80, 90, 100, 110, 125	–	80, 90, 100, 110, 125, 150, 175, 200, 225, 250
Ekip LS/I	[In A]	–	10, 25, 60, 100, 125	–	40, 60, 100, 150, 225, 250
Ekip I	[In A]	–	10, 25, 60, 100, 125	–	40, 60, 100, 150, 225, 250
Ekip LSI	[In A]	–	10, 25, 60, 100, 125	–	40, 60, 100, 150, 225, 250
Ekip LSIG	[In A]	–	10, 25, 60, 100, 125	–	40, 60, 100, 150, 225, 250
Ekip E-LSIG	[In A]	–	–	–	40, 60, 100, 150, 225, 250
Interchangeability		–	Yes	–	Yes

⁽¹⁾ XT4 2-pole version is available in the N breaking capacity only.

⁽²⁾ XT2 and XT4 in the H, L and V breaking capacities are current limiting circuit breakers.

⁽³⁾ Available in 3-pole and 2-poles (N) version only.

Circuit breakers for power distribution

Thermomagnetic trip units

TMF

Main characteristics:

- available for XT1 and XT3 in the three-pole and four-pole versions;
- protections:
 - against overload (L): fixed $I_1 = I_n$ protection threshold, with inverse long-time trip curve;
 - against instantaneous short-circuits (I): fixed $10 \times I_n$ protection threshold at 500A for $I_n < 50A$ and $10 \times I_n$ for $I_n \geq 50A$, with instantaneous trip curve;

2

Example with XT1 125A

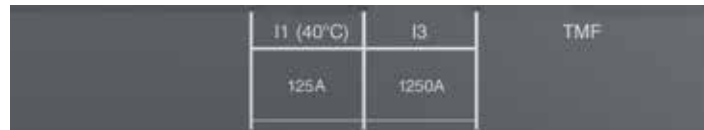

XT1

TMF

L	$I_1 = 1 \times I_n$	I_n [A]	15	20	25	30	35	40	45	50	60	70	80	90	100	110	125
		I_1	15	20	25	30	35	40	45	50	60	70	80	90	100	110	125
I	$I_3 = 10 \times I_n$	I_n [A]	15	20	25	30	35	40	45	50	60	70	80	90	100	110	125
		I_3	500	500	500	500	500	500	500	500	600	700	800	900	1000	1100	1250

XT3

TMF

L	$I_1 = 1 \times I_n$	I_n [A]	60	70	80	90	100	110	125	150	175	200	225
		I_1	60	70	80	90	100	110	125	150	175	200	225
I	$I_3 = 10 \times I_n$	I_n [A]	60	70	80	90	100	110	125	150	175	200	225
		I_3	600	700	800	900	1000	1110	1250	1500	1750	2000	2250

TMF/TMA

Main characteristics:

- available for XT2 and XT4 in the two-pole (XT4 N version only) three-pole and four-pole versions, except where noted;
- protections:
 - against overload (L):
 - fixed protection threshold $I_1=I_n$;
 - adjustable protection threshold from 0.7...1xIn, with inverse long time trip curve;
 - against instantaneous short-circuit (I):
 - fixed protection threshold at $I_1=400A$ for $I_n<40A$ and $I_1=10xI_n$ for $I_n\geq 40A$;
 - adjustable threshold between 5...10xIn;
- the thermal and magnetic protection settings on the TMA versions are made by turning the corresponding dials on the front of the release.

Example with XT4 250A



XT2

TMF/TMA

		In [A]	15 ⁽¹⁾	20 ⁽¹⁾	25 ⁽¹⁾	30 ⁽¹⁾	35 ⁽¹⁾	40 ⁽¹⁾	50	60	70	80	90	100	110	125
			I ₁ = 1xIn (TMF)	I ₁ TMF	I ₁ TMA	I ₃ = 400A (TMF)	I ₃ TMF	I ₃ TMA	I ₃ = 10xIn (TMF)	I ₃ TMF	I ₃ TMA	I ₃ = 5...10xIn (TMA)	I ₃ TMA			
L	I ₁ = 1xIn (TMF)	I ₁ TMF	15	20	25	30	35	40	50	60	70	80	90	100	110	125
	I ₁ = 0.7...1xIn (TMA)	I ₁ TMA	-	-	-	-	-	-	-	-	-	56...80	63...90	70...100	77...110	87.5...125
I	I ₃ = 400A (TMF)	I ₃ TMF	400	400	400	400	400	400	-	-	-	-	-	-	-	-
	I ₃ = 10xIn (TMF)	I ₃ TMF	-	-	-	-	-	-	500	600	700	-	-	-	-	-
	I ₃ = 5...10xIn (TMA)	I ₃ TMA	-	-	-	-	-	-	-	-	-	400...800	450...900	500...1000	550...1100	625...1250

⁽¹⁾ Available as complete circuit breaker only.

XT4

TMF/TMA

		In [A]	25	30	35	40	50	60	70	80 ⁽²⁾	90 ⁽²⁾	100 ⁽²⁾	110 ⁽²⁾	125 ⁽²⁾
			I ₁ = 1xIn (TMF)	I ₁ TMF	I ₁ TMA	I ₃ = 400A (TMF)	I ₃ TMF	I ₃ TMA	I ₃ = 10xIn (TMF)	I ₃ TMF	I ₃ TMA	I ₃ = 5...10xIn (TMA)	I ₃ TMA	
L	I ₁ = 1xIn (TMF)	I ₁ TMF	25	30	35	40	50	60	70	80	90	100	110	125
	I ₁ = 0.7...1xIn (TMA)	I ₁ TMA	-	-	-	-	-	-	-	56...80	63...90	70...100	77...110	87.5...125
I	I ₃ = 400A (TMF)	I ₃ TMF	400	400	400	400	-	-	-	-	-	-	-	-
	I ₃ = 10xIn (TMF)	I ₃ TMF	-	-	-	-	500	600	700	800	900	1000	1100	1250
	I ₃ = 5...10xIn (TMA)	I ₃ TMA	-	-	-	-	-	-	-	400...800	450...900	500...1000	550...1100	625...1250

⁽¹⁾ Available as loose trip unit only.

TMF/TMA

		In [A]	150 ⁽¹⁾	175 ⁽¹⁾	200 ⁽¹⁾	225 ⁽¹⁾	250
			I ₁ = 1xIn (TMF)	I ₁ TMF	I ₁ TMA	I ₃ = 10xIn (TMF)	I ₃ TMF
L	I ₁ = 1xIn (TMF)	I ₁ TMF	150	175	200	225	250
	I ₁ = 0.7...1xIn (TMA)	I ₁ TMA	105...150	122.5...175	140...200	157.5...225	175...250
I	I ₃ = 10xIn (TMF)	I ₃ TMF	1500	1750	2000	2250	2500
	I ₃ = 5...10xIn (TMA)	I ₃ TMA	750...1500	875...1750	1000...2000	1125...2250	1250...2500

⁽²⁾ TMF version available in 3-pole and 2-pole (N) versions only.

Circuit breakers for power distribution

Electronic trip units

Ekip I

Main characteristics:

- usable with the XT2 and XT4 circuit breaker in the three-pole and four-pole versions;
- protections:
 - against instantaneous short-circuit (I): adjustable protection threshold from 1...10xIn, with instantaneous trip curve;
 - of the neutral in four-pole circuit breakers:
 - for $I_n \geq 100A$ in the OFF or ON positions, 50% and 100% of the phases can be selected;
 - for $I_n < 100A$, neutral protection is fixed at 100% of the phases and disabled by user;
- manual setting using the corresponding dip-switches, which allow the settings to be made even when the trip unit is off;
- LED:
 - LED lit with a steady green light indicating that the trip unit is supplied correctly. The LED comes on when the current exceeds 0.2xIn;
 - LED with a steady red light, indicating that protection I has tripped; red LED light on connecting Ekip TT or Ekip T&P accessories after circuit breaker opening for “I protection” intervention;
 - Ekip I is equipped with a trip coil disconnection protection device that detects whether the opening solenoid has disconnected. Signaling is made by a flashing red LED;
- test connector on the front of the trip unit;
 - the Ekip TT trip test unit, allows trip test, LED test and signaling the latest trip;
 - the Ekip T&P unit, allows the measurements to be read, the trip test to be conducted and the I protection function test to be carried out;
- self-supply from a minimum current of 0.2xIn up.



Ekip I

Protection function	Trip threshold	Trip curve ⁽¹⁾	Excludability	Relation
 Against short-circuits with adjustable threshold and instantaneous trip time	Manual setting: $I_3 = 1, 1.5, 2, 2.5, 3, 3.5, 4.5, 5.5, 6.5, 7, 7.5, 8, 8.5, 9, 10 \times I_n$ Tolerance: $\pm 20\% I > 4I_n$ $\pm 10\% I \leq 4I_n$	$\leq 20ms$	Yes	$t = k$

⁽¹⁾ Tolerances in case of:
 – self-powered trip unit at full power;
 – 2 or 3-phase power supply.
 In conditions other than those stated, the trip time is $\leq 60ms$.

Ekip LS/I

Main characteristics:

- available for XT2 and XT4 in the three-pole and four-pole versions;
- protections:
 - against overload (L): 0.4...1xIn adjustable protection threshold, with adjustable time trip curve;
 - against short-circuit with delay (S): 1...10xIn adjustable protection threshold, with adjustable time trip curve (as an alternative to I protection);
 - against instantaneous short-circuit (I): 1...10xIn adjustable protection threshold, with instantaneous trip curve (as an alternative to S protection);
 - of the neutral in four-pole circuit breakers:
 - for $I_n \geq 100A$ can be selected in the OFF or ON positions, 50%, 100% of the phases;
 - for $I_n < 100A$, neutral protection is fixed at 100% of the phases and disabled by user;
- manual setting using the corresponding dip-switches on the front of the trip unit, which allow the settings to be made even when the trip unit is off;
- LED:
 - LED with steady green light indicating that the trip unit is supplied correctly. The LED comes on when the current exceeds 0.2xIn;
 - red LED for each protection:
 - L: LED with steady red light, indicates pre-alarm for current exceeding 0.9xI₁;
 - L: LED with flashing red light, indicates alarm for current exceeding set threshold;
 - LS/I: LED with steady red light, shows that a protection has tripped. After the circuit breaker has opened, connect the Ekip TT or Ekip T&P accessory to find out which protection function tripped the trip unit;
- Ekip LS/I is equipped with a trip coil disconnection detection device that detects whether the opening solenoid has disconnected. Signaling is made by all the red LEDs flashing simultaneously;
- test connector on the front of the release:
 - the Ekip TT trip test unit, allows trip test, LED test and signaling about the latest trip;
 - the Ekip T&P unit, allows the measurements to be read, the trip test to be conducted and the protection functions test to be carried out;
- thermal memory which can be activated by Ekip T&P;
- self-supply from 0.2xIn minimum current up.

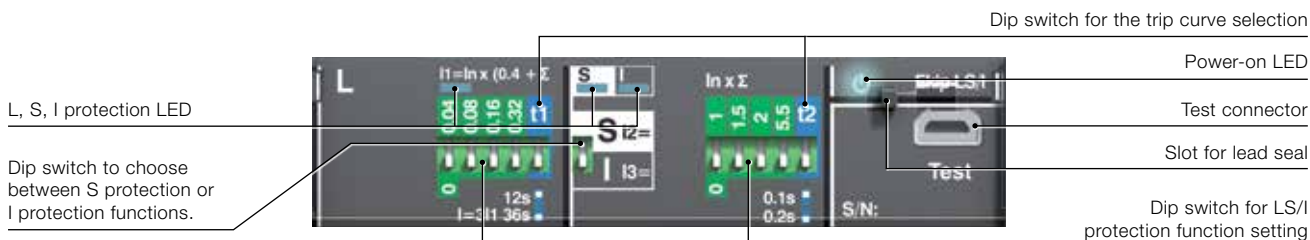

Ekip LS/I

Protection function	Trip threshold	Trip curve ⁽¹⁾	Excludability	Relation	Thermal memory
L Against overloads with long inverse time delay trip and trip characteristic according to an inverse time curve ($t^2t=k$)	Manual setting: $I_1 = 0.4...1xI_n$ step 0.04 Tolerance: trip between 1.05...1.3 I_1	Manual setting: $t_1 = 12-36s$ at $I=3xI_1$ Tolerance: $\pm 10\%$ up to $4xI_n$ $\pm 20\%$ from $4xI_n$	–	$t = k/I^2$	Yes
S Against short-circuits with independent time delay ($t=k$)	Manual setting: $I_2 = 1-1.5-2-2.5-3-3.5-4.5-5.5-6.5-7-7.5-8-8.5-9-10xI_n$ Tolerance: $\pm 10\%$	$t_2 = 0.1-0.2s$ Tolerance: $\pm 15\%$	Yes	$t = k$	–
I Against short-circuits with adjustable threshold and instantaneous trip time	Manual setting: $I_3 = 1-1.5-2-2.5-3-3.5-4.5-5.5-6.5-7-7.5-8-8.5-9-10xI_n$ Tolerance: $\pm 10\%$	$\leq 20ms$	Yes	$t = k$	–

⁽¹⁾ Tolerances in case of:
 – self-powered trip unit at full power;
 – 2- or 3-phase power supply.
 In conditions other than those stated, the following tolerances hold:

Protection	Trip threshold	Trip time
L	release between 1.05 and $1.3 \times I_1$	$\pm 20\%$
S	$\pm 10\%$	$\pm 20\%$
I	$\pm 15\%$	$\leq 60ms$

Circuit breakers for power distribution

Electronic trip units

Ekip LSI and Ekip LSIG

Main characteristics:

- available for XT2 and XT4 in three-pole and four-pole versions;
- protections:
 - against overloads (L): $0.4 \dots 1 \times I_n$ adjustable protection threshold, with adjustable time trip curve;
 - against short-circuits with delay (S): $1 \dots 10 \times I_n$ adjustable protection threshold, with adjustable time trip curve (short inverse time ($t=k^2$) or independent time ($t=k$));
 - against instantaneous short-circuits (I): $1 \dots 10 \times I_n$ adjustable protection threshold, with instantaneous trip curve;
 - against ground faults (G): $0.2 \dots 1 \times I_n$ adjustable protection threshold, with independent time trip curve;
 - of the neutral in four-pole circuit breakers:
 - for $I_n \geq 100A$ can be selected in OFF or ON, 50%, 100% of phases;
 - for $I_n < 100A$ neutral protection is fixed on 100% of phases and disabled by user;
- setting:
 - manual setting using the corresponding dip-switches on the front of the trip unit, which allows the settings to be made even when the trip unit is off;
 - electronic setting, made both locally using the Ekip T&P or Ekip Display accessory and via remote control, by means of the Ekip Com unit;
- LED:
 - LED on with steady green light indicating that the trip unit is supplied correctly. The LED comes on when the current exceeds $0.2 \times I_n$;
 - red LED for each protection:
 - L: LED with steady red light, indicates pre-alarm for current exceeding $0.9 \times I_1$;
 - L: LED with flashing red light, indicates alarm for current exceeding set threshold;
 - LSIG: LED with steady red light, shows that a protection has tripped. After the circuit breaker has opened, connect the Ekip TT or Ekip T&P accessory to find out which protection function tripped the trip unit;
 - the trip unit is equipped with a device that detects the eventual opening solenoid disconnection thanks to the simultaneous blinking of all the LED;
- test connector on the front of the release:
 - the Ekip TT trip test unit allows trip test, LED test and signaling about the latest trip;
 - the Ekip T&P unit allows measurements to be read, trip test to be conducted, protection functions test to be carried out, electronic setting of the trip unit's protection functions and communication parameters;
- thermal memory which can be activated by Ekip T&P or Ekip Display;
- self-supply from a minimum current of $0.2 \times I_n$ up;
- the three-pole version can be accessorized with external neutral;
- with the addition of the Ekip Com in the circuit breaker, you can:
 - acquire and transmit a wide range of information via remote control;
 - command the circuit breaker to open and close by means of the motor operator in the electronic version (MOE-E);
 - know the state of the circuit breaker (open/closed/trip) via remote control;
 - set the configuration and program the unit, such as the current thresholds and the protection function curves.

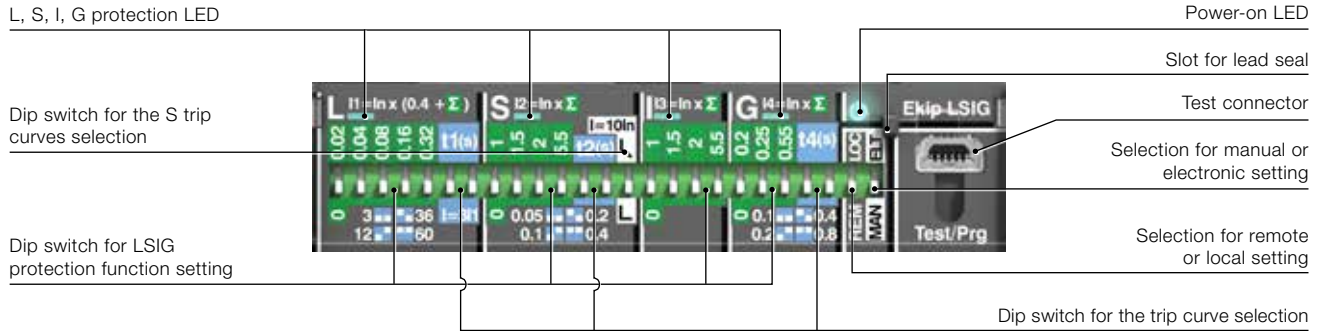

Ekip LSI – Ekip LSIG

Protection function	Trip threshold	Trip curve ⁽¹⁾	Excludability	Relation	Thermal memory
L Against overloads with long inverse time delay trip and trip characteristic according to an inverse time curve ($t^2=k$)	Manual setting: $I_1 = 0.4 \dots 1 \times I_n$ step 0.02 Tolerance: trip between 1.05...1.3 I_1 (IEC 60947-2)	Manual setting: $t_1 = 3-12-36-60s$ at $I = 3 \times I_1$ Tolerance: $\pm 10\%$ up to $4 \times I_n$ $\pm 20\%$ from $4 \times I_n$	-	$t = k/I^2$	Yes
	Electronic setting: $I_1 = 0.4 \dots 1 \times I_n$ step 0.01 Tolerance: trip between 1.05...1.3 I_1 (IEC 60947-2)	Electronic setting: $t_1 = 3 \dots 60s$ at $I = 3 \times I_1$ step 0.5 Tolerance: $\pm 10\%$ up to $4 \times I_n$ $\pm 20\%$ from $4 \times I_n$	-	$t = k/I^2$	Yes
S Against short-circuits with inverse short ($t=k/I^2$) or independent ($t=k$) time delay trip	Manual setting: $I_2 = 1-1.5-2-2.5-3-3.5-4.5-5.5-6.5-7-7.5-8-8.5-9-10 \times I_n$ Tolerance: $\pm 10\%$	Manual setting: $t_2 = 0.05-0.10-0.20-0.40s$ at $10 \times I_n$ Tolerance: $\pm 10\%$ up to $4 \times I_n$ $\pm 20\%$ from $4 \times I_n$	Yes	$t = k/I^2$	-
	Electronic setting: $I_2 = 1 \dots 10 \times I_n$ step 0.1 Tolerance: $\pm 10\%$	Electronic setting: $t_2 = 0.05 \dots 0.40s$ at $10 \times I_n$ step 0.01 Tolerance: $\pm 10\%$ up to $4 \times I_n$ $\pm 20\%$ from $4 \times I_n$	Yes	$t = k/I^2$	-
	Manual setting: $I_2 = 1-1.5-2-2.5-3-3.5-4.5-5.5-6.5-7-7.5-8-8.5-9-10 \times I_n$ Tolerance: $\pm 10\%$	Manual setting: $t_2 = 0.05-0.1-0.2-0.4s$ Tolerance: $\pm 15\%$ $t_2 > 100ms$ $\pm 20\%$ $t_2 \leq 100ms$	Yes	$t = k$	-
	Electronic setting: $I_2 = 1 \dots 10 \times I_n$ step 0.1 Tolerance: $\pm 10\%$	Electronic setting: $t_2 = 0.05 \dots 0.4s$ step 0.01 Tolerance: $\pm 15\%$ $t_2 > 100ms$ $\pm 20\%$ $t_2 \leq 100ms$	Yes	$t = k$	-
I Against short-circuits with adjustable threshold and instantaneous trip time	Manual setting: $I_3 = 1-1.5-2-2.5-3-3.5-4.5-5.5-6.5-7-7.5-8-8.5-9-10 \times I_n$ Tolerance: $\pm 10\%$	$\leq 40ms$	Yes	$t = k$	-
	Electronic setting: $I_3 = 1 \dots 10 \times I_n$ step 0.1 Tolerance: $\pm 10\%$	$\leq 40ms$	Yes	$t = k$	-
G Against ground fault with independent time delay trip ⁽²⁾	Manual setting: $I_4 = 0.2-0.25-0.45-0.55-0.75-0.8-1 \times I_n$ Tolerance: $\pm 10\%$	Manual setting: $t_4 = 0.1-0.2-0.4-0.8s$ Tolerance: $\pm 15\%$	Yes	$t = k$	-
	Electronic setting: $I_4 = 0.2 \dots 1 \times I_n$ step 0.02 Tolerance: $\pm 10\%$	Electronic setting: $t_4 = 0.1 \dots 0.8s$ step 0.05 Tolerance: $\pm 15\%$	Yes	$t = k$	-

⁽¹⁾ Tolerances in case of:
 - self-powered trip unit at full power;
 - 2- or 3-phase power supply.
 In conditions other than those stated, the following tolerances hold:

Protection	Trip threshold	Trip time
L	release between 1.05 and 1.3 x I_1	$\pm 20\%$
S	$\pm 10\%$	$\pm 20\%$
I	$\pm 15\%$	$\leq 60ms$
G	$\pm 15\%$	$\pm 20\%$

⁽²⁾ Protection G is inhibited for currents higher than 2 In.

Circuit breakers for power distribution

Electronic trip units

Ekip E-LSIG

Main characteristics:

- available for XT4 in three-pole and four-pole versions;
- protections:
 - against overloads (L): $0.4 \dots 1 \times I_n$ adjustable protection threshold, with adjustable time trip curve;
 - against short-circuits with delay (S): $1 \dots 10 \times I_n$ adjustable protection threshold, with adjustable time trip curve;
 - against instantaneous short-circuits (I): $1 \dots 10 \times I_n$ adjustable protection threshold, with instantaneous trip curve;
 - of the neutral in four-pole circuit breakers;
- measurements:
 - available from $0.2 \times I_n$ in Vaux mode and starting from $0.5 \times I_n$ in self supply mode; external current or voltage transformers are not required. See table for ranges and accuracy;
 - Currents: three phases (L_1, L_2, L_3), neutral (Ne) and ground fault;
 - Voltage: phase-phase, phase-neutral;
 - Power: active, reactive and apparent;
 - Power factor;
 - Frequency and peak factor;
 - Energy: active, reactive, apparent, counter;
- setting:
 - manual setting using the corresponding dip-switches on the front of the trip unit, which allow the settings to be made even when the trip unit is off;
 - electronic setting, made both locally using Ekip T&P or Ekip Display accessory and via remote control, by means of the dialog unit Ekip Com. The electronic settings have a wider range and more regulation steps. Use of electronic setting allows other functions to be activated:
 - function for protection against ground faults (G): $0.2 \dots 1 \times I_n$ adjustable protection threshold, with a time constant trip curve;
 - over voltage protection $0.5 \dots 0.95 U_n$ with a time constant trip curve;
 - under voltage protection $1.05 \dots 1.2 U_n$ with a time constant trip curve;
- LED:
 - LED on with steady green light indicating that the trip unit is supplied correctly. The LED comes on when the current exceeds $0.2 \times I_n$;
 - red LED for each protection:
 - L: LED with steady red light, indicates pre-alarm for current exceeding $0.9 \times I_1$;
 - L: LED with flashing red light, indicates alarm for current exceeding set threshold;
 - fixed LED MAN/ELT shows the version of active parameters;
 - LSIG: LED with steady red light, shows that a protection has tripped. After the circuit breaker has opened, connect the Ekip TT or Ekip T&P accessory to find out which protection function tripped the trip unit;
 - the trip unit is equipped with a device that detects the opening solenoid disconnection. It is communicated by the simultaneous blinking of all the LEDs;
- test connector on the front of the release:
 - the Ekip TT trip test unit, allows trip test, LED test and signaling about the latest trip;
 - the Ekip T&P unit allows measurements to be read, trip test to be conducted, protection functions test to be carried out, electronic setting of the trip unit's protection functions and communication parameters;
- self-supply from a minimum current of $0.2 \times I_n$ up; measurements starting from $0.5 \times I_n$;
- the three-pole version can be accessorized with external neutral current transformer and external neutral voltage connection kit;
- with the addition of Ekip Com in the circuit breaker, you can:
 - acquire and transmit a wide range of information via remote control;
 - command the circuit breaker to open and close by means of the motor operator in the electronic version (MOE-E);
 - know the circuit breaker's state (open/closed/trip) via remote control;
 - set the configuration and program the unit, such as the current thresholds and the protection function curves.

L, S, I protection LED

LED for electronic/manual setting

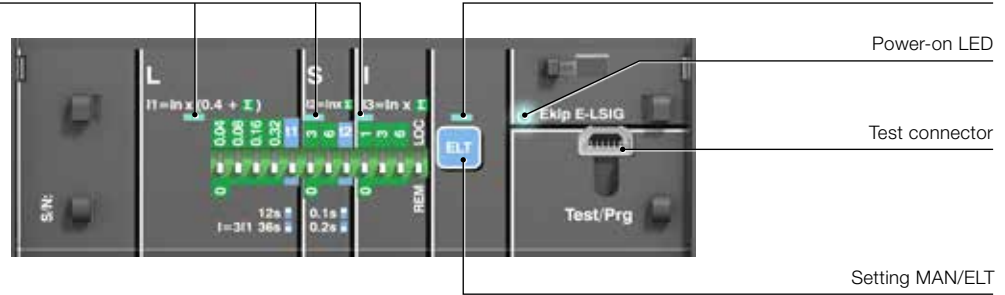

Ekip E-LSIG

Protection function	Trip threshold	Trip curve ⁽¹⁾	Excludability	Relation	Thermal memory
L Against overloads with long inverse time delay trip and trip characteristic according to an inverse time curve ($t^2=k$)	Manual setting: $I_1 = 0.4 \dots 1 \times I_n$ step 0.04 Tolerance: trip between $1.05 \dots 1.3 I_1$ (IEC 60947-2)	Manual setting: $t_1 = 12 \dots 36s$ at $I = 3 \times I_1$ Tolerance: $\pm 10\%$ up to $4 \times I_n$ $\pm 20\%$ from $4 \times I_n$	-	$t = k/I^2$	-
	Electronic setting: $I_1 = 0.4 \dots 1 \times I_n$ step 0.01 Tolerance: trip between $1.05 \dots 1.3 I_1$ (IEC 60947-2)	Electronic setting: $t_1 = 3 \dots 60s$ at $I = 3 \times I_1$ step 0.5 Tolerance: $\pm 10\%$ up to $4 \times I_n$ $\pm 20\%$ from $4 \times I_n$	-	$t = k/I^2$	-
S Against short-circuits with inverse short ($t=k/I^2$) or independent ($t=k$) time delay trip	Manual setting: $I_2 = \text{OFF } 3 \dots 9$ Tolerance: $\pm 10\%$	Manual setting: $t_2 = 0.10 \dots 0.20s$ at $10 \times I_n$ Tolerance: $\pm 10\%$ up to $4 \times I_n$ $\pm 20\%$ from $4 \times I_n$	Yes	$t = k$	-
	Electronic setting: $I_2 = 1 \dots 10 \times I_n$ step 0.1 Tolerance: $\pm 10\%$	Electronic setting: $t_2 = 0.05 \dots 0.4s$ at $10 \times I_n$ step 0.01 Tolerance: $\pm 10\%$ up to $4 \times I_n$ $\pm 20\%$ from $4 \times I_n$	Yes	$t = k/I^2$	-
	Electronic setting: $I_2 = 1 \dots 10 \times I_n$ step 0.1 Tolerance: $\pm 10\%$	Electronic setting: $t_2 = 0.05 \dots 0.4s$ step 0.01 Tolerance: $\pm 10\%$ up to $4 \times I_n$ $\pm 20\%$ from $4 \times I_n$	Yes	$t = k$	-
I Against short-circuits with adjustable threshold and instantaneous trip time	Manual setting: $I_3 = \text{OFF } 1 \dots 10$ Tolerance: $\pm 10\%$	$\leq 40ms$	Yes	$t = k$	-
	Electronic setting: $I_3 = 1 \dots 10 \times I_n$ step 0.1 Tolerance: $\pm 10\%$	$\leq 40ms$	Yes	$t = k$	-
G Against ground fault with independent time delay trip ⁽²⁾	Electronic setting: $I_4 = 0.2 \dots 1 \times I_n$ step 0.02 Tolerance: $\pm 10\%$	Electronic setting: $t_4 = 0.1 \dots 0.8s$ step 0.05s Tolerance: $\pm 15\%$	Yes	$t = k$	-
UV Against undervoltage with adjustable constant time	Electronic setting: $U_g = 0.5 \dots 0.95 \times U_n$ step $= 0.01 \times U_n$ Tolerance: $\pm 5\%$	Electronic setting: $t_g = 0.1 \dots 5s$ step 0.1s Tolerance: min ($\pm 20\% \pm 100ms$)	Yes	$t = k$	-
OV Against overvoltage with adjustable constant time	Electronic setting: $U_g = 1.05 \dots 1.2 \times U_n$ step $= 0.01 \times U_n$ Tolerance: $\pm 5\%$	Electronic setting: $t_g = 0.1 \dots 5s$ step 0.1s Tolerance: min ($\pm 20\% \pm 100ms$)	Yes	$t = k$	-

⁽¹⁾ Tolerances in case of:
 - self-powered trip unit at full power;
 - 2- or 3-phase power supply.
 In conditions other than those stated, the following tolerances hold:

Protection	Trip threshold	Trip time
L	release between 1.05 and $1.3 \times I_1$	$\pm 20\%$
S	$\pm 10\%$	$\pm 20\%$
I	$\pm 15\%$	$\leq 60ms$
G	$\pm 15\%$	$\pm 20\%$

⁽²⁾ Protection G is inhibited for currents higher than $2 I_n$.

Circuit breakers for power distribution

Electronic trip units

2

		Value	Range	Accuracy	Specified measuring range
Current		Phase current (I1, I2, I3, IN)	0...12 In	Cl 1	0.2...1.2 In
		Phase current minimum value			
		Phase current maximum value			
		Ground current (I _g)	0...4 In	–	–
Voltage		Phase voltage runtime, max and min (V1N, V2N, V3N) ⁽¹⁾	5V...480V	±0.5%	30V...400V
		Line voltage runtime, max and min (U12, U23, U31)	10V...828V	±0.5%	50V...690V
Power	Active	Phase power runtime, max and min (P1, P2, P3) ⁽¹⁾	-1440kW...1440kW	Cl 2	-120kW...-1,5kW 1,5kW...120kW ⁽³⁾
		Total power runtime, max and min	-4320kW...4320kW	Cl2	-360kW...-4,5kW 4,5kW...360kW ⁽³⁾
	Reactive	Phase power runtime, max and min (Q1, Q2, Q3) ⁽¹⁾	-1440kVar...1440kVar	Cl 2	-120kVar...-1,5kVar 1,5kVar...120kVar ⁽³⁾
		Total power runtime, max and min	-4320kVar...4320kVar	Cl 2	-360kVar...-4,5kVar 4,5kVar...360kVar ⁽³⁾
	Apparent	Phase power runtime, max and min (S1, S2, S3) ⁽¹⁾	InVA...1440kVA	Cl 2	1,5kVA...120kVA
		Total power runtime, max and min	750VA...4320kVA	Cl 2	4,5kVA...369kVA
Energy	Active	Total energy	1 kWh...214,75 GWh	Cl 2	1 kWh...214,75 GWh
		Incoming energy			
		Outgoing energy			
	Reactive	Total energy	1 kvarh...214,75 GVarh	Cl 2	1 kvarh...214,75 GVarh
		Incoming energy			
		Outgoing energy			
Apparent	Total energy	1 kVAh...214,75 GVAh	Cl 2	1 kVAh...214,75 GVAh	
Power quality		Harmonic analysis ⁽²⁾	11th (50 - 60Hz)	–	–
		THD of phase L1, L2, L3 ⁽²⁾	0...1000%	±10%	0 ... 500%
		Frequency runtime, max, min	44...440Hz	±0.5%	45 ... 66 Hz
		PF of phase L1, L2, L3 ⁽¹⁾	-1...1	±2%	-1 ... -0.5 0.5 ... 1

⁽¹⁾ Not available if Neutral is not connected

⁽²⁾ Available on demand by sending a Modbus command

⁽³⁾ For $0,2 \cdot I_n < I_i < 1,2 \cdot I_n$ and $30V < V_i < 400V$

Circuit breakers for motor protection

Main characteristics

When choosing and manufacturing a system for starting (G4.3 and G4.4) and monitoring motors, a given solution's safety and reliability are important considerations. Start-up is a particularly critical phase for the motor itself and for the installation powering it. Even rated service needs to be adequately monitored and protected in order to deal with any faults that might occur.

When it comes to direct starting, ABB SACE offers two different solutions:

- **a conventional system** equipped with a circuit breaker with a magnetic only trip unit for protection against short-circuits, a thermal relay for protection against overloads

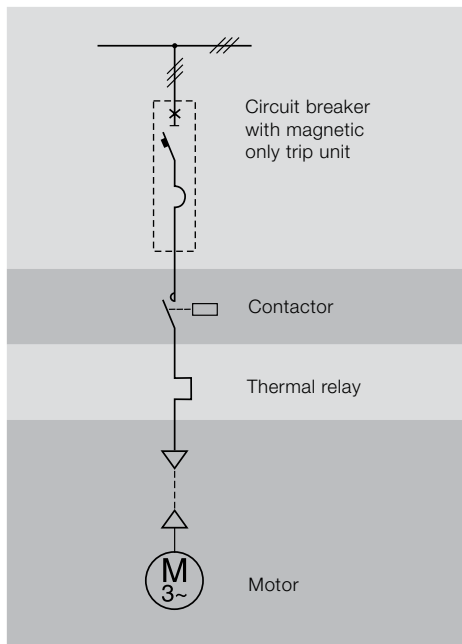

Conventional system

and phase failure or imbalance, and a contactor to operate the motor;

- **an advanced protection system** which integrates all the protection and monitoring functions in the circuit breaker itself and a contactor for operating the motor.

Several different factors must be considered when choosing and coordinating the protection and operating devices, e.g.:

- the electrical specifications of the motor (type, power rating, efficiency, $\cos\phi$);
- the starting type and diagram;
- the fault current and voltage in the part of the network where the motor is installed.

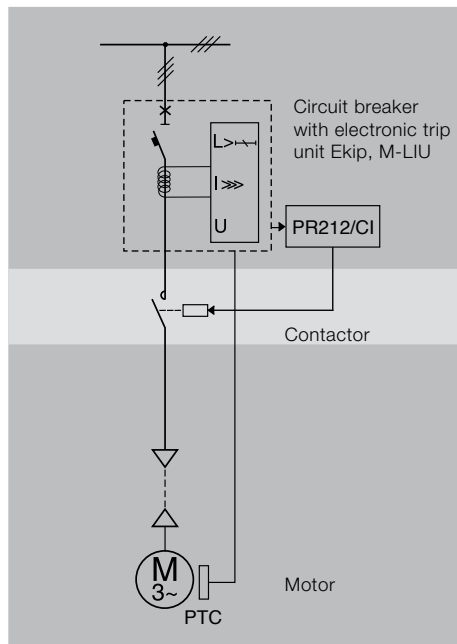

Advanced protection system

Characteristics of circuit breakers for motor protection

		XT1	XT2	XT3	XT4
Size ^(G2.1)	[A]	125	125	225	150/250
Poles	[No.]	3	3	3	3
Rated service voltage, U_e ^(G2.4)	(AC) 50-60Hz	[V] 600Y/347	600	600Y/347	600
	(DC)	[V] 500	500	500	600
Versions		Fixed, Plug-in	Fixed, Plug-in, Withdrawable	Fixed, Plug-in	Fixed, Plug-in, Withdrawable
Breaking capacities		H	H	S	H
Trip Units		Magnetic	Magnetic, Electronic	Magnetic	Magnetic, Electronic
MA (MCP)	[In A]	3, 7, 15, 30, 50, 70, 80, 100, 125	3, 7, 15, 30, 50, 70, 80, 100, 125	100, 110, 125, 150, 200	25, 50, 80, 100, 110, 125, 150, 175, 200, 225, 250
Ekip M-LIU (MPCB)	[In A]	–	25, 60, 100	–	40, 60, 100, 150

Circuit breakers for motor protection

Magnetic trip units

MA (MCP)

Main characteristics:

- available for XT1, XT2, XT3 and XT4 in the three-pole version only. These trip units are mainly used for protecting motors, in conjunction with a thermal relay and a contactor;
- protections:
 - against instantaneous short-circuit (I) for XT1: the protection threshold I is adjustable from 4...11xIn for $I_n \leq 7A$ and 3...11xIn for $I_n > 7A$;
 - against instantaneous short-circuit (I) for XT2: for $I_n \leq 7A$ the protection threshold I is adjustable from 4...11xIn for $15A \leq I_n \leq 100A$ the protection threshold I is adjustable from 3...11xIn, whereas for $I_n = 125A$, the protection threshold I is adjustable from 5...10xIn;
 - against instantaneous short-circuit (I) for XT3: the protection threshold I is adjustable from 6...12xIn;
 - against instantaneous short-circuit (I) for XT4: for $I_n \leq 50A$, the protection threshold I is adjustable from 3...11xIn, whereas for $I_n > 50A$ the protection threshold I is adjustable from 5...10xIn;
- the magnetic protection setting is made by turning the appropriate dial on the front of the release.

Rotary dial for magnetic protection setting

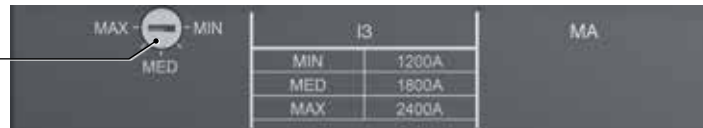

XT1

MA (MCP)

I	In [A]	3	7	15	30	50	70	80	100	125
		$I_3 = 4...11xIn$	I_3	12...33	28...77	–	–	–	–	–
	$I_3 = 3...11xIn$	I_3	–	45...165	90...330	150...550	210...770	240...880	300...1100	375...1375

XT2

MA (MCP)

I	In [A]	3	7	15	30	50	70	80	100	125
		$I_3 = 4...11xIn$	I_3	12...33	28...77	–	–	–	–	–
	$I_3 = 3...11xIn$	I_3	–	45...165	90...330	150...550	210...770	240...880	300...1100	–
	$I_3 = 5...10xIn$	I_3	–	–	–	–	–	–	–	625...1250

XT3

MA (MCP)

I	In [A]	100	110	125	150	200
		$I_3 = 6...12xIn$	I_3	600...1200	660...1320	750...1500

XT4

MA (MCP)

I	In [A]	25	50	80	100	110	125	150	175	200	225	250
		$I_3 = 3...11xIn$	I_3	75...275	150...550	–	–	–	–	–	–	–
	$I_3 = 5...10xIn (>50A)$	I_3	–	400...800	500...1000	550...1100	625...1250	750...1500	875...1750	1000...2000	1125...2250	1250...2500

Circuit breakers for motor protection

Electronic trip units

Ekip M-LIU (MPCB)

Main characteristics:

- available for XT2 and XT4 in the three-pole version, this device protects motors. The L protection function protects the motor against overloads, in accordance with the indications and classes defined by standard IEC 60947-4-1;
- protections:
 - against overloads (L): $0.4...1xI_n$ adjustable threshold. The operating time is established by choosing the operating class defined by Standard IEC 60947-4-1. Class 3E, 5E, 10E, 20E;
 - against short-circuits (I): $6...13xI_n$ adjustable threshold with instantaneous operating time;
 - against phase loss (U): the protection can be selected either in the ON or OFF position. When the selector is in the ON position, the threshold is $50\% I_1$, with fixed operating time;
- manual setting using the corresponding dip-switches on the front of the release;
- LED:
 - LED on with steady green light indicating that the trip unit is supplied correctly. The LED comes on when the current exceeds $0.2xI_n$;
 - red LED for each protection:
 - L: LED with steady red light, indicates pre-alarm for current exceeding $0.9xI_1$;
 - L: LED with flashing red light, indicates alarm for current exceeding set threshold;
 - LIU: LED with steady red light, shows that a protection has tripped. After the circuit breaker has opened, connect the Ekip TT or Ekip T&P accessory to find out which protection function tripped the trip unit;
 - Ekip M-LIU is equipped with a trip coil disconnection device that detects whether the opening solenoid has disconnected. Signal is all red LEDs flashing simultaneously;
- test connector on the front of the release:
 - the Ekip TT trip test unit, allows trip test, LED test and signaling about the latest trip;
 - the Ekip T&P unit allows measurements to be read, trip test to be conducted and protection function test to be carried out;
- thermal memory always active;
- self-supply starting from a minimum current of $0.2xI_n$;
- compliant with UL60947-4-1.



Ekip M-LIU

Protection function	Trip threshold	Trip curve ⁽¹⁾	Excludability	Relation	Thermal memory
L Against overloads with long inverse time delay trip and trip characteristic according to an inverse time curve ($i^2t=k$)	Manual setting: $I_1 = 0.4...1xI_n$ step 0.04 Tolerance: trip between $1.05...1.2xI_1$	Manual setting: Operating class: 3E, 5E, 10E, 20E Tolerance: $\pm 10\%$ up to $4xI_n$ $\pm 20\%$ from $4xI_n$	–	$t = k/I^2$	Yes
I Against short-circuits with adjustable threshold and instantaneous trip time	Manual setting: $I_3 = 6...13xI_n$ step 1 Tolerance: $\pm 10\%$	$\leq 20ms$	–	$t = k$	–
U Against phase loss with independent time delay (IEC 60947-4-1)	Manual setting: $I_6 = ON / OFF$ When ON, $I_6 = 50\% I_1$ Tolerance: $\pm 15\%$	Manual setting: When ON, $t_6 = 2s$ Tolerance: $\pm 10\%$	Yes	$t = k$	–

⁽¹⁾ Tolerances in case of:
– self-powered trip unit at full power;
– 2- or 3-phase power supply.
In conditions other than those stated, the following tolerances hold:

Protection	Trip threshold	Trip time
L	release between 1.05 and $1.2 x I_1$	$\pm 20\%$
I	$\pm 15\%$	$\leq 60ms$
U	$\pm 20\%$	$\pm 20\%$

Molded case switch disconnectors

Main characteristics

2



XT1D



XT2D



XT3D



XT4D

The molded case switch disconnector ("switch") is a device created from the corresponding circuit breakers. It features the same overall dimensions, versions, fastening mechanisms and can be fitted with accessories.

Its main function is to disconnect the circuit it's installed in. In the open position, the switch disconnects and ensure sufficient insulation distance between contacts for safety and to prevent an electrical arc from striking.

Applications

Molded case switch disconnectors are normally used as:

- general sub-switchboard disconnectors;
- operating/disconnecting devices for lines, pan-assemblies or groups of equipment;
- bus-ties;
- general disconnecting devices for groups of machines;
- general group disconnecting devices for motor operation and protection;
- insulation of small tertiary distribution units.

Protection

A switch is unable to automatically break the short-circuit or overload current. For this reason, each molded case switch disconnector must be protected on the supply side by a coordinated device that safeguards it against short-circuits.

Ic [A]	XT1	XT2	XT3	XT4
AC 22A	125	125	225	250
AC 23A	125	125	200	200
DC 22A	125	125	225	250
DC 23A	125	125	200	200

Characteristics of molded case switch disconnectors

		XT1	XT2	XT3	XT4
Size ^(G2.1)	[A]	125	125	225	150/250
Poles	[No.]	3, 4	3, 4	3, 4	3, 4,
Rated service voltage, Ue ^(G2.4)	(AC) 50-60Hz [V]	600Y/347	600	600Y/347	600
	(DC) [V]	500 4p series ⁽¹⁾	500 3p series	500 3p series	500 2p series
Versions		Fixed, Plug-in	Fixed, Plug-in, Withdrawable	Fixed, Plug-in	Fixed, Plug-in, Withdrawable
Rating level		N S H	N H L V	N S	N S H L V
Magnetic Override	[A]	1500	1500	2700	3000

⁽¹⁾ 3p CB up to 250V DC 3p series

Switch disconnector coordination

Supply side	Version	Icu	Load side				
			In	XT1D	XT2D	XT3D	XT4D
XT1	N	25	125	25	25	25	25
	S	35		35	35	35	35
	H	65		65	65	65	65
XT2	N	25	125	25	25	25	25
	S	35		35	35	35	35
	H	65		65	65	65	65
	L	100		65	100	65	100
XT3	V	150		65	150	65	150
	N	25	225			25	25
	S	35				35	35
XT4	N	25	250			25 ⁽¹⁾	25
	S	35				35 ⁽¹⁾	35
	H	65				65 ⁽¹⁾	65
	L	100				65 ⁽¹⁾	100
	V	150				65 ⁽¹⁾	150

⁽¹⁾ The configuration is valid only with I_c < 225A setting on XT4 circuit breaker

Current Limiting

Electrical characteristics

Current, existing UL circuit breakers Tmax XT2 and Tmax XT4 have undergone specific tests as per the UL 489 Standard in order to be classified as UL Current Limiting circuit breakers. They have specific characteristics in terms of limiting peak current and specific let-through energy.

According to the UL 489 Standard, Current Limiting circuit breakers will be signed "Current Limiting" on the front and will have a label on the right side specifying peak current and specific let-through energy values. Accessories and trip are the same as available for standard UL Tmax MCCBs.

Tmax XT Current Limiting

		XT2						XT4					
Trip Units		TMF, TMA, EKIP						TMF, TMA, EKIP					
In	[A]	Up to 125A ⁽¹⁾						Up to 250A ⁽²⁾					
Voltage Rating	[V AC]	480V AC			600V AC			480V AC			600V AC		
Breaking Capacities		H	L	V	H	L	V	H	L	V	H	L	V
Threshold Current													
I _{rms}	[kA]	6	6	6	6	6	6	10	10	10	10	10	10
I _p	[kA]	10	10	10	10	10	10	14,4	14,4	14,4	13,7	13,7	13,7
I ² t	[10 ⁶ A ² s]	266	266	266	301	301	301	499	499	499	582	582	582
Intermediate Point [®]													
I _{rms}	[kA]	30	50	65	14	22	25	42	50	65	18	22	30
I _p	[kA]	19	21	23,2	14,1	18	18	26,4	26,4	30	19,1	22,3	24,2
I ² t	[10 ⁶ A ² s]	480	486	512	472	655	655	853	853	980	791	990	1058
Interrupting Rating													
I _{rms}	[kA]	65	100	150	25	35	42	65	100	150	25	50	50
I _p	[kA]	23,2	31,1	31,1	18	20	21,4	30	44,5	44,5	22,3	30,4	30,4
I ² t	[10 ⁶ A ² s]	512	704	704	655	650	691	980	1142	1142	990	1162	1162

(1) Includes TMF, TMA with I_n = 15-125A and Ekip with I_n= 10,25,60,100,125A
(2) Includes TMF, TMA with I_n = 25-250A and Ekip with I_n= 40,60,100, 150,225,250A

Special applications

Communication system

2

The XT2 and XT4 molded case circuit breakers, equipped with an Ekip LSI, Ekip LSI^G or Ekip E-LSIG trip unit and Ekip Com dialog module, can be integrated in monitoring systems to control and manage electrical and technological plants. The protocol available for communication on bus^(G5,4) is Modbus RTU.

Communications accessories include:

- Ekip Com communication module and electronic auxiliary contacts (1 Q + 1 SY) included in the Ekip Com module. For further details, see the "Accessories" chapter.
- Electronic motor operator MOE-E.

Configuration 1: Monitoring (Electronic trip unit and Ekip Com)

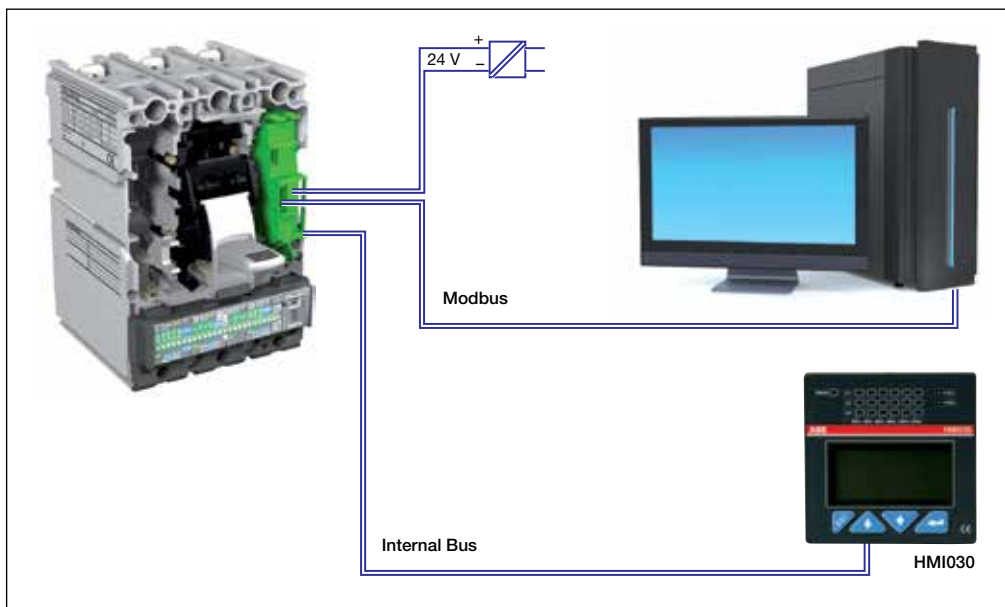

Positioned in the right-hand slot of the circuit breaker, the Ekip Com accessory connects to the Ekip LSI, Ekip LSI^G or Ekip E-LSIG trip unit via the supplied connector. Six cables come out of Ekip Com. Two are required for auxiliary supply, two for connection to the Modbus and two for connection to Internal Bus.

This configuration allows you to:

- read the measurements and settings from the electronic trip unit in remote mode;
- program the electronic trip unit in remote mode;
- know the state of the circuit breaker (Open/Closed/Tripped) in remote mode;
- locally visualize the relevant information of the circuit breaker on the HMI030.

Consult the Electric Diagrams chapter for further details about wiring.

Configuration 2: Monitoring and remote control (Thermomagnetic trip unit or molded case switch disconnecter, Ekip Com and MOE-E)

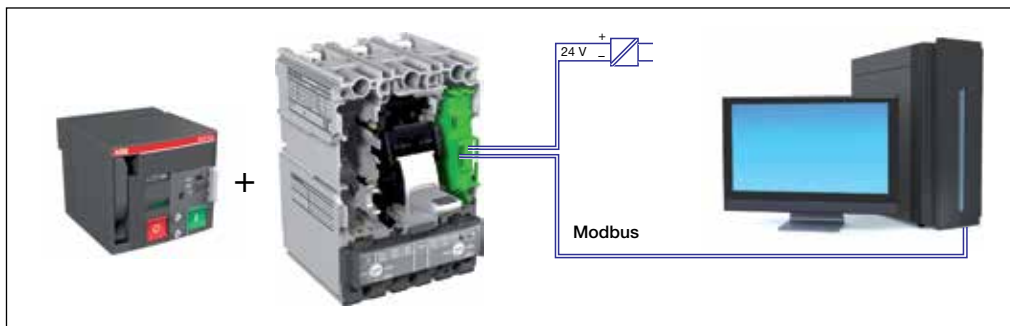

The Ekip Com accessory is positioned in the right-hand slot of the circuit breaker and attaches to a connector at the rear of the MOE-E. Six cables come out of the Ekip Com. Two are needed for the auxiliary power supply and two for connection to the Modbus.

- With this configuration, it is possible to:
- read the Open/Closed/Tripped state of the circuit breaker remotely;
 - open/close the circuit breaker or molded case switch disconnecter remotely.

For further details about cabling the various devices, please refer to the "Electric diagrams" chapter.

Configuration 3: Monitoring and remote control (Electronic trip unit, Ekip Com and MOE-E)

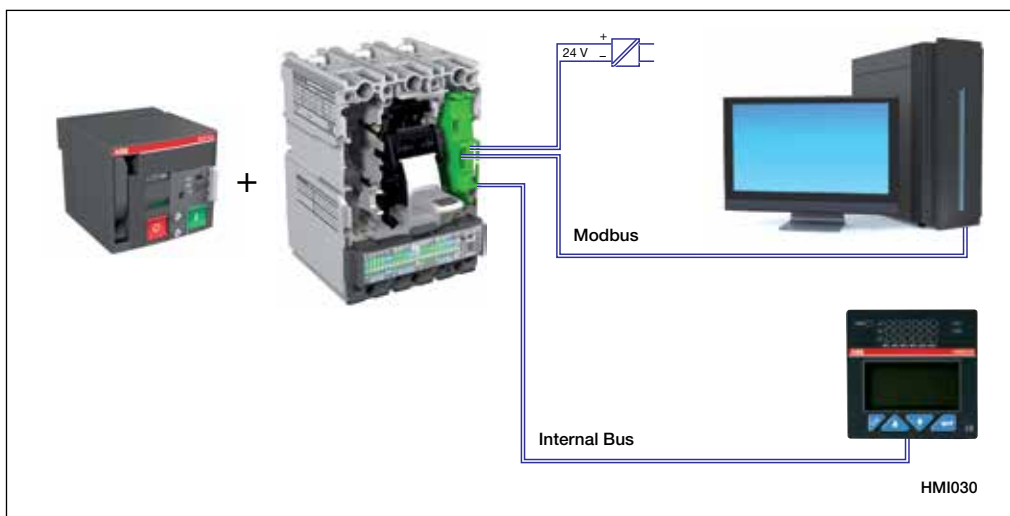

Positioned in the right-hand slot of the circuit breaker, the Ekip Com accessory connects to the Ekip LSI, Ekip LSIg or Ekip E-LSIG trip unit via connector supplied with Ekip Com and to the MOE-E via connector on that unit. Six cables come out of Ekip Com. Two are required for auxiliary supply, two for connection to the Modbus and two for connection to the Internal Bus.

- This configuration allows you to:
- read the measurements and settings from the solid-state release in remote mode;
 - program the electronic trip unit in remote mode;
 - read the state of the circuit breaker (Open/Closed/Tripped) in remote mode;
 - open/close the circuit breaker in remote mode;
 - visualize locally on HMI 030 all the relevant information of the circuit breaker.

Consult the "Electric diagrams" chapter for further details about wiring.

Special applications

Communication system

Configuration 4: Interface from front panel (Electronic trip unit and HMI030 unit)

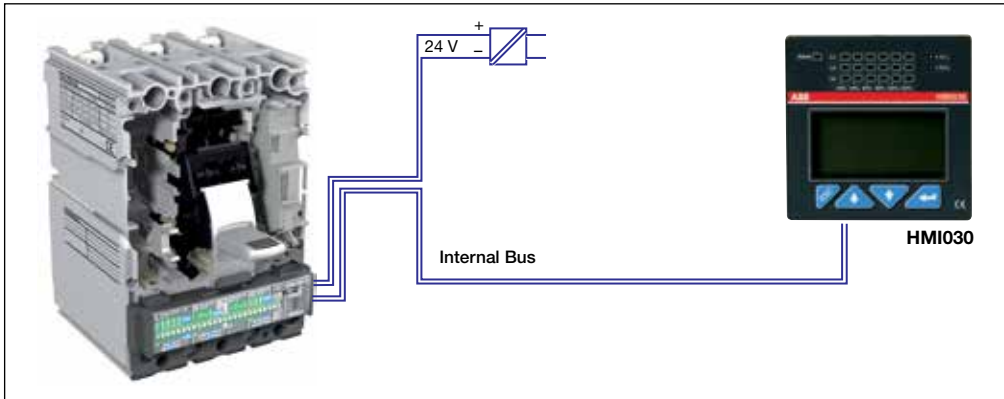

When XT2 and XT4 circuit breakers are equipped with an Ekip LSI, Ekip LSI or Ekip E-LSIG electronic trip unit plus an HM1030 interface, electrical values and the most recent trip information can be displayed directly on the panel door.

The necessary accessories, are:

- interface device HMI030;
- kit of 24V DC auxiliary voltage for electronic trip unit.

Four cables come out of the Ekip E-LSIG, Ekip LSI or Ekip LSI or Ekip LSI or Ekip LSI trip unit. Two are needed for the auxiliary power supply and two for connection to the HMI030 on Internal Bus.

This configuration allows measurements and alarms from the electronic trip unit to be read on the HM1030 interface accessory, positioned on the front of the panel.

For further details on cabling the various devices, refer to the "Electric diagrams" chapter.

Measurement, signaling and available data functions

	Ekip LSI Ekip LSIG	Ekip E-LSIG	Ekip LS/I TM Molded case switch disconnecter
Electrical quantities			
Phase current (I_{L1}, I_{L2}, I_{L3})	■	■	
Neutral current (I_N) ⁽¹⁾	■	■	
Ground current (I_g)	■ ⁽¹⁾	■	
Phase to phase voltage ($V_{12}-V_{23}-V_{31}$)		■	
Phase-Neutral Voltage ($V_{1N}-V_{2N}-V_{3N}$) ⁽²⁾		■	
Frequency		■	
Power (active P, reactive Q, apparent S) total power and phase power ⁽²⁾		■	
Power factor (total and phase) ⁽²⁾		■	
Energy (active, reactive, apparent) total		■	
Harmonic calculation (THDI, specter)		■	
Status information			
CB status (open, closed, tripped)	■	■	■
Modality (local, remote)	■	■	
Protection parameters	■	■	
Thermal memory	■	■	
Maintenance data			
Total number of operations	■	■	
Total number of protection trips	■	■	
Total number of trip tests	■	■	
Total number of manual operations	■	■	
Total number of failed trips	■	■	
Last trip data recording	20	20	
Protection alarm			
I Protection (trip)	■	■	
S Protection (timing and trip)	■	■	
L Protection (timing and trip)	■	■	
G Protection (timing and trip)	■ ⁽¹⁾	■	
L Protection pre-alarm ⁽³⁾	■	■	
Diagnostic Alarm			
Trip command failed	■	■	
Trip coil disconnected	■	■	
Commands			
CB Open/CB Close (with MOE-E motor operator)	■	■	■
CB Reset (with MOE-E motor operator)	■	■	■
Alarm reset	■	■	
Trip test	■	■	
Protection parameter setting	■	■	
Run Time Events			
CB status changes, protection status change and alarms status change	■	■	

⁽¹⁾ Only with Ekip LSIG trip unit

⁽²⁾ Measurements available only with Neutral connected

⁽³⁾ $90\%I_1 < I < 105\%I_1$

Versions and types

Fixed part of Plug-in and withdrawable versions	3/2
Conversion kits	3/3

Mechanical accessories

Connection terminals	3/5
Terminal covers and phase separators	3/12
Rotary handle operating mechanism	3/12
IP54 Protection	3/12
Front for operating lever mechanism	3/12
Locks	3/14
Rear mechanical interlock	3/16
Bracket for fixing on DIN rail	3/16
Flanges	3/17

Electrical accessories

Service releases	3/18
Auxiliary contacts	3/20
Motor operators	3/25
Connectors for electrical accessories	3/29
Residual current releases	3/30

Accessories for electronic trip units

Ekip Display	3/36
Ekip LED Meter	3/37
Current sensor for external neutral	3/37
Connection accessories	3/37

Communication devices and systems

HMI030 interface on the front of the switchboard	3/38
Ekip Com	3/39
Ekip Connect	3/40

Test and configuration accessories

Ekip T&P	3/41
Ekip TT	3/41
Automatic network-generator transfer unit ATS021-ATS022	3/42

Compatibility of accessories

	3/44
--	------

Accessories

Versions and types



Fixed circuit breaker

Tmax XT circuit breakers are available in the following versions:

- **FIXED.** These have a current-interrupting part connected to the trip unit, to be installed on the back plate of the box;
- **PLUG-IN.** These have a moving part and a fixed part. The latter must be installed on the back plate of the box. The moving part comes in the kit that converts the fixed version into a plug-in version;
- **WITHDRAWABLE.** These have a moving part and a fixed part, equipped with side runners to allow easy racking in/out of the moving part. The fixed part is installed on the back plate of the box. The moving part comes in the kit that converts the fixed version into a withdrawable version. To create the withdrawable circuit breaker, it's necessary to order a front accessory to maintain the IP40 degree of protection over the circuit breaker's entire isolation run.

If the plug-in circuit breaker is fitted with electrical accessories, appropriate connectors for insulating the corresponding auxiliary circuits must also be ordered. For the withdrawable version, there are dedicated accessories fitted with connectors enabling automatic disconnection when racking-out. (Consult the "Connectors for electrical accessories" section of this chapter).

Using the fixed version as a base, SACE Tmax XT circuit breakers can easily be converted into plug-in and withdrawable versions with the appropriate conversion kits. The moving part can always be obtained in the required version, fully pre-engineered in the factory, by ordering the fixed circuit breaker and the conversion kit at the same time.



Plug-in circuit breaker

	Version		
	Fixed	Plug-in	Withdrawable
XT1	■	■	
XT2	■	■	■
XT3	■	■	
XT4	■	■	■



Withdrawable circuit breaker

Fixed part of plug-in and withdrawable versions

The fixed parts of the plug-in/withdrawable versions are available with extended front terminals (EF). The fixed parts can be equipped with some of the same terminal, terminal-cover and phase barrier kits used for the fixed circuit breakers, by using the proper adapter.

The fixed parts of a plug-in/withdrawable circuit breaker can be installed at a distance of 50mm/1.97in from the back of the panel or at 70mm/2.76in as shown in the picture.

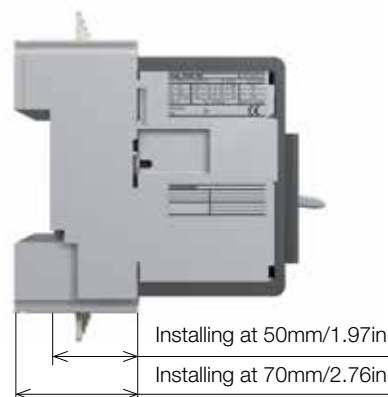



Conversion kit for turning a fixed circuit breaker into the moving part of a plug-in circuit breaker



Conversion kit for turning a fixed circuit breaker into the moving part of a withdrawable circuit breaker



Conversion kit for turning a fixed part of plug-in version into the fixed part of a withdrawable version

Conversion kits

The following conversion kits can be obtained in order to create the different versions:

- **Kit for converting the fixed circuit breaker into the moving part of plug-in/ withdrawable versions.** When withdrawable versions are made, it is essential to order an accessory to apply to the front of the circuit breaker in order to maintain the IP40 degree of protection over the entire isolation run. This accessory can be chosen from:
 - front for lever operating mechanism (FLD);
 - motor operator (MOE);
 - direct or extended rotary handle operating mechanisms (RHD or RHE).
 If no accessory is indicated, the front for lever operating mechanism (FLD) is automatically included in the order.
- **Kit for converting the fixed part of plug-in versions into the fixed part of withdrawable versions.** The kit comprises:
 - a guide for turning the fixed part of the plug-in circuit breaker into the fixed part of the withdrawable circuit breaker;
 - a racking-out rotary handle that allows the moving part to be inserted and withdrawn. The mechanism allows the circuit breaker to be set to the isolated position (with the power and auxiliary circuits disconnected) with the compartment door closed, for operator safety. The rotary handle can only be inserted when the circuit breaker is open. Once it has been removed or withdrawn, the circuit breaker can be set to the open/ closed position;
 - a flange for the compartment door, which replaces the one supplied with the fixed version of the circuit breaker.
- **Kit for converting fixed type into the plug-in version for RC Sel residual current devices for XT2-XT4.** RC Sel four-pole residual current devices for XT2 and XT4 can be converted from the fixed version into the plug-in version using the special kit.
- **Kit for converting plug-in types into the withdrawable version for RC Sel residual current devices for XT2-XT4.** RC Sel four-pole residual current devices for XT2 and XT4 can be converted from the plug-in version to the withdrawable version using the special kit, which comprises a bellows to apply to the front of the residual current device so as to allow it and the residual current part to be withdrawn when the panel door is closed. This kit can also be assembled on fixed circuit breakers fitted with the front part for locks or the direct rotary handle, thus adding to the range of uses for residual current devices. In the plug-in to withdrawable conversion kit, there is also a 6-pin connector to be applied onto the right side of the circuit breaker to facilitate disconnecting the auxiliary circuits connected to the residual current device. This kit contains also the shunt opening release of the residual current device dedicated to the withdrawable version, which is fitted with a connector for the fixed part and the moving part.

Accessories

Versions and types

Plug-in version

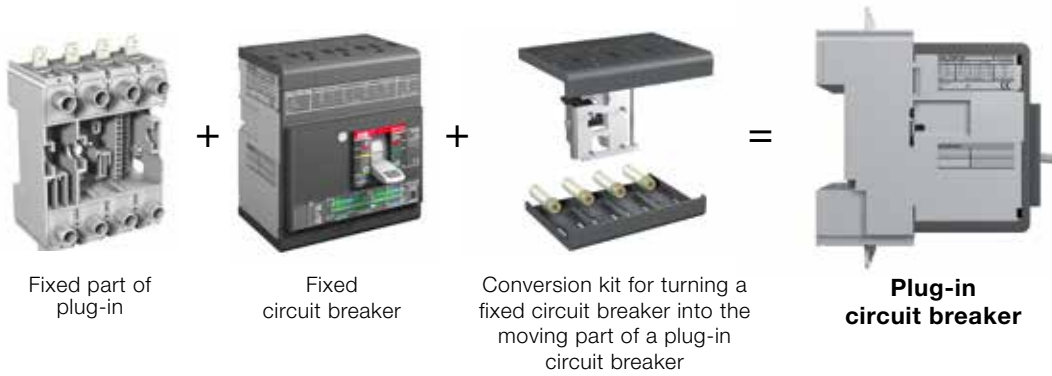

Withdrawable version

1st solution

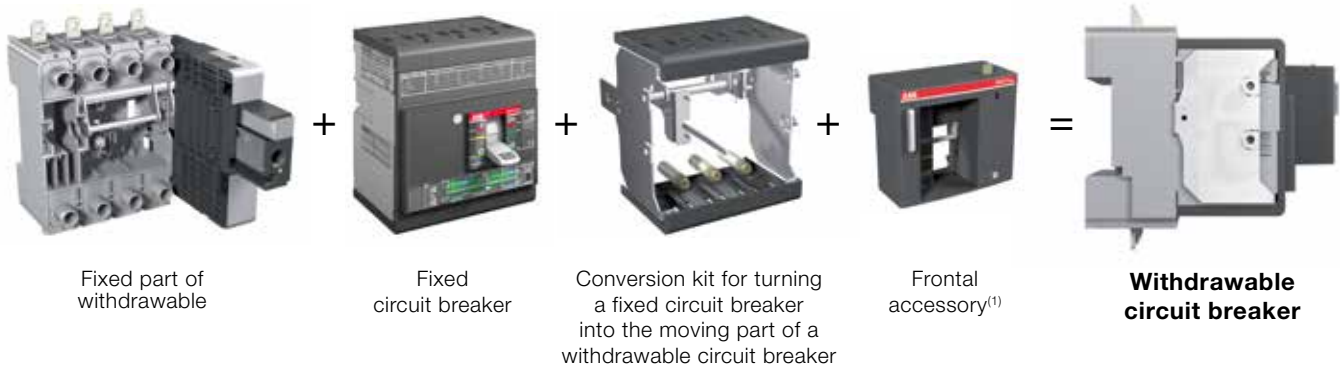

2nd solution

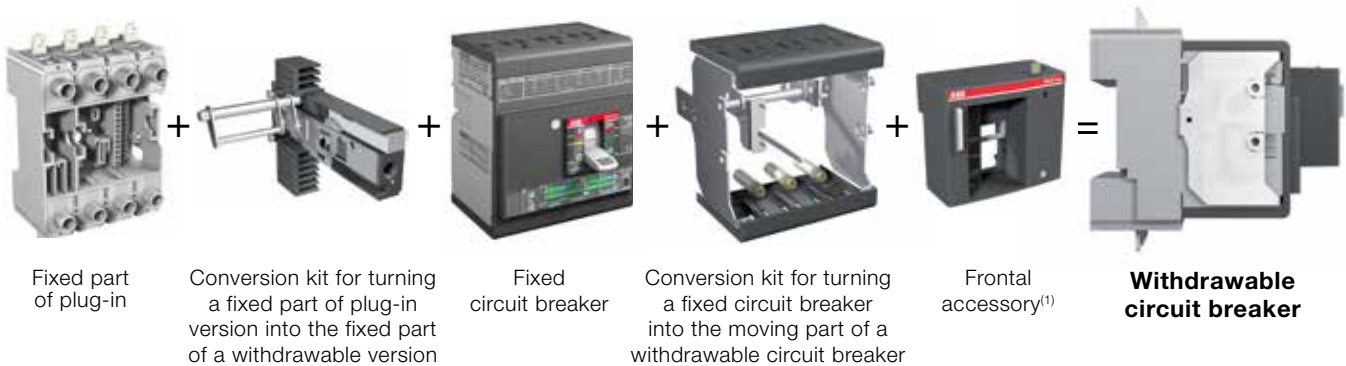

⁽¹⁾ Frontal accessory is mandatory. If not specified in the order, the FLD is supplied automatically

Accessories

Mechanical accessories

		UL Listed	XT1	XT2	XT3	XT4
Terminals	F - Front terminals	■	■	■	■	■
	EF - Extended front terminals	■	■	■	■	■
	ES - Extended spread terminals	■	■	■	■	■
	FCCu - Front for copper cables	■	■	■	■	■
	FCCuAl - Front for copper/aluminum cables	■	—	—	■	■
	FB - For flexible busbars	—	■	■	■	■
	MC - Multi cable for copper cable	■	■	■	■	■
	R - Rear oriented	—	■	■	■	■
	EF - Extended front for the fixed part	■	■	■	■	■
	HR/VR - Horizontal rear / Vertical rear for fixed part	—	■	■	■	■
	R for RC - Rear for residual current release	—	■	—	■	—
	Terminal covers	LTC - Low terminal cover	■	■	■	■
HTC - High terminal cover		■	■	■	■	■
Phase barriers	PB - 25mm/0.98in	■	■	■	■	■
	PB - 100mm/3.94in	■	■	■	■	■
	PB - 200mm/7.87in	■	■	■	■	■
Flange handle operating mechanism	MKC - Cable operated flange handles	■	■	■	■	■
Rotary handle operating mechanism	RHD - Direct rotary handle	■	■	■	■	■
	RHE - Extended rotary handle	■	■	■	■	■
	RHS - Side rotary handle (right and left sides)	■	■	■	■	■
	LH - Long "pistol" rotary handle (for RHE or RHS)	■	■	■	■	■
	RHL - Rotary handle/front lever lock, open	■	■	■	■	■
	RHL - Rotary handle/front lever lock, open/closed	■	■	■	■	■
Front for operating lever mechanism	FLD - Front for locks	■	—	■	—	■
Locks on circuit breaker	PLL - Padlock device, removable	■	■	—	■	—
	PLL - Padlock device, open	■	■	■	■	■
	PLL - Padlock device, open/closed	■	■	■	■	■
	KLC - Key lock, open	■	■	■	■	■
	KLC - Key lock, open/closed	■	■	■	■	■
Mechanical interlock	MIR - Mechanical interlock (HR and VR)	■	■	■	■	■

Connection terminals

Connection terminals allow the circuit breaker to be connected to the system in the way best suited to the installation requirements. By and large, they consist of front terminals for connecting cables or busbar directly from the front of the circuit breaker.

Where possible, the terminals have laser markings on the surface to indicate the tightening torques for the correct isolation of cables and bars.

Fixed version

Standard SACE Tmax XT circuit breakers for UL and CSA are supplied with front terminals (F). However, they can be fitted with the following types of terminal as accessories thanks to the special kits:

- extended front (EF);
- extended spread front (ES);
- front for copper/aluminum cables (FCCuAl), for XT3 and XT4 sizes;
- front for copper cables (FCCu);
- multicable for copper cable (MC);
- for flexible busbar (FB);
- rear oriented (R).

For XT1 and XT3 sizes, the use of non-insulated busbar with $U_e \leq 480V$ involves the mandatory assembly of terminal-covers HTC.

Accessories

Mechanical accessories

3

Plug-in and withdrawable versions

The fixed part of plug-in and withdrawable version circuit-breakers is normally supplied with extended front terminals (EF) or horizontal/vertical rear terminals (HR/VR).

Horizontal/vertical rear terminals (HR/VR) are factory-mounted in the horizontal position. If needed, the terminals can easily be field-rotated to the vertical position.

A fixed part with front terminals (EF) can be converted into a fixed part with rear terminals (HR/VR) by ordering the appropriate terminal kit. The fixed parts can also be fitted with some of the same types of terminal available on the fixed circuit breaker after an adapter has been installed on the terminal zone of the fixed part itself. Consequently, the following types of connection terminals are also acceptable for use with the fixed part:

- extended spread front (ES);
- for copper cables (FCCu);
- multi-cable (MC).
- for copper and aluminum cables (FCCuAl);
- for flexibar (FB).

The adapter mimics the terminal zone of the fixed circuit breaker. This means that fixed parts can also be equipped with the same terminal covers and phase separators as those used for fixed circuit breakers.

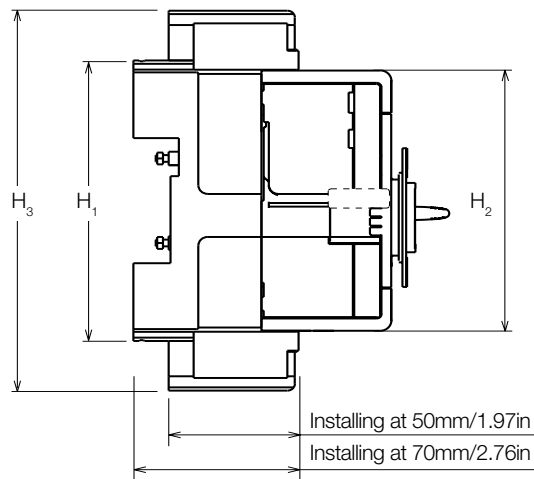

Fixed part adapter

Fixed part adapter

Circuit breakers	H ₁ fixed part [mm/in]	H ₂ circuit breaker [mm/in]	H ₃ fixed part with two adapters [mm/in]
XT1	146/5.75	134/5.28	181/7.13
XT2	153/6.02	134/5.28	188/7.40
XT3	166/6.54	154/6.06	225/8.86
XT4	182/7.17	164/1.46	228/8.98

Front terminals - F ⁽¹⁾

CB.	Vers.	Busbar dimensions [mm/in]						Cable terminals [mm/in]		Tightening [Nm/lb-in]	H Terminal covers [mm/in]			H Phase separators [mm/in]			
		W min	W max	H	Ø	D min	D max	W	Ø		Cable or busbar /Terminal	2/0.08	50/1.97	60/2.36	25/0.98	100/3.94	200/7.87
XT1	F	13/0.512	16/0.630	7.5/0.295	6.5/0.256	3.5/0.138	5/0.197	16/0.630	6.5/0.256	M6	6/53.1	-	R	-	S	R	R
XT2	F	13/0.512	20/0.787	7.5/0.295	6.5/0.256	2.5/0.098	5/0.197	20/0.787	6.5/0.256	M6	6/53.1	-	R	-	S	R	R
XT3	F	17/0.669	25/0.984	9.5/0.374	8.5/0.335	5/0.197	8/0.315	24/0.945	8.5/0.335	M8	8/70.8	-	-	R	S	R	R
XT4	F	17/0.669	25/0.984	10/0.394	8.5/0.335	5/0.197	8/0.315	25/0.984	8.5/0.335	M8	8/70.8	-	-	R	S	R	R

⁽¹⁾ UL Listed



Front terminal - F



F terminal with cable lug



F terminal with busbar

Front extended terminals - EF ⁽¹⁾

CB	Vers.	Busbar dimensions [mm/in]			Cable terminals [mm/in]		Tightening [Nm/lb-in]		H Terminal covers [mm/in]			H Phase separators [mm/in]				
		W	D	Ø	W	Ø	Terminal /CB	Cable or busbar /Terminal	2/0.08	50/1.97	60/2.36	25/0.98	100/3.94	200/7.87		
XT1	F	20/0.787	4/0.157	8.5/0.335	20/0.787	8.5/0.335	M6	6/53.1	M8	9/79.7	-	R	-	-	S	R
XT2	F	20/0.787	4/0.157	8.5/0.335	20/0.787	8.5/0.335	M6	6/53.1	M8	9/79.7	-	S	-	-	S	R
XT3	F	20/0.787	6/0.236	10/0.394	20/0.787	10/0.394	M8	8/70.8	M10	18/159.3	-	-	R	-	S	R
XT4	F	20/0.787	10/0.394	10/0.394	20/0.787	10/0.394	M8	8/70.8	M10	18/159.3	-	-	S	-	S	R

⁽¹⁾ UL Listed



Front extended terminal - EF



EF terminal with cable lug



EF terminal with busbar

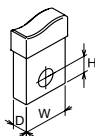

- W** Width
- H** Hole height
- D** Depth
- F** Fixed
- P** Plug-in
- W** Withdrawable
- Ø** Diameter
- S** Standard
- R** On Request

Accessories

Mechanical accessories

3

Front extended spread terminals - ES ⁽¹⁾

CB	Vers.	Busbar dimensions MAX [mm/in]			Cable terminals [mm/in]		Tightening [Nm/lb-in]			H Terminal covers [mm/in]			H Phase separators [mm/in]			
		W	D	Ø	W	Ø	Terminal /CB	Cable or busbar /Terminal	2/0.08	50/1.97	60/2.36	25/0.98	100/3.94	200/7.87		
XT1	F-P	25/0.984	4/0.157	8.5/0.335	25/0.984	8.5/0.335	M6	6/53.1	M8	9/79.7	-	-	-	-	-	S
XT2	F-P-W	30/1.181	4/0.157	10.5/0.413	30/1.181	10.5/0.413	M6	6/53.1	M10	18/159.3	-	-	-	-	-	S
XT3	F-P	30/1.181	4/0.157	10.5/0.413	30/1.181	10.5/0.413	M8	8/70.8	M10	18/159.3	-	-	-	-	-	S
XT4	F-P-W	30/1.181	10/0.394	10.5/0.413	30/1.181	10.5/0.413	M8	8/70.8	M10	18/159.3	-	-	-	-	-	S

⁽¹⁾ UL Listed



Front extended spread terminal - ES



ES terminal with cable lug



ES terminal with busbar

Terminals for copper cables - FCCu ⁽²⁾

CB	Type of terminal	Vers.	Cable		Inner dimensions [mm/in]	Tightening [Nm/lb-in]	L cable stripping [mm/in]	H Terminal covers [mm/in]			H Phase separators [mm/in]		
			AWG/kcmil	mm ²				Cable or busbar/Terminal	2/0.08	50/1.97	60/2.36	25/0.98	100/3.94
XT1 ⁽³⁾	internal	F-P	1x14...1/0	1x2.5...70	12x12/0.472x0.472	7/61.95	16/0.629	-	R	-	S ⁽¹⁾	R	R
XT1 ⁽⁴⁾	internal	F-P	1x14...1/0	1x1.5...70	9,5x16/0.37x0.63	7/61.95	16/0.629	-	R	-	S ⁽¹⁾	R	R
XT2	internal	F-P-W	1x14...1/0	1x2.5...95	14x14/0.551x0.551	<50mm ² (1/10 AWG): 7/61.95 ≥50mm ² (1/10 AWG): 8,5/75.23	14/0.551	-	R	-	S ⁽¹⁾	R	R
XT3	internal	F-P	1x10...250	1x6...185	18x18/0.709x0.709	14/123.91	20/0.787	-	-	R	S ⁽¹⁾	R	R
XT4	internal	F-P	1x10...250	1x6...185	18x18/0.709x0.709	14/123.91	16/0.787	-	-	R	S ⁽¹⁾	R	R
XT4	internal	F-P	1x14-1/0	1x2.5...50	1x2.5...50	-	-	-	-	-	-	-	-

⁽¹⁾ Phase separators are supplied as standard with the basic version of the circuit breaker; ⁽²⁾ UL Listed; ⁽³⁾ MCCB only application; ⁽⁴⁾ MCCB/MCP application.



FCCu terminal



FCCu terminal with cable



FCCu terminal with busbar

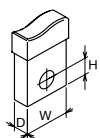

- W** Width
- H** Hole height
- D** Depth
- F** Fixed
- P** Plug-in
- W** Withdrawable
- Ø** Diameter
- S** Standard
- R** On Request

Terminals for copper cables - FCCuAI ⁽¹⁾

CB	Type of terminal	Vers.	Cable		Tightening [Nm/lb-in]		L cable stripping [mm/in]	H Terminal covers [mm/in]			H Phase separators [mm/in]			
			AWG/kcmil	mm ²	Terminal/CB	Cable or busbar/Terminal		2/0.08	50/1.97	60/2.36	25/0.98	100/3.94	200/7.87	
XT2	internal	F-P	1x14...1/0	1x2.5...50	2.5/22.12	M6	≤ 8mm ² (8 AWG):4.5/39.82 > 8mm ² (8 AWG) 5.7/50.44	15,5/0.61	-	-	-	S	R	R
XT3	internal	F-P	1x14...1/0	1x2.5...50	9/79.7	slot	5.6/50	15,5/0.61	-	-	-	S	R	R
	internal	F-P	1x4...300	1x25...150	9/79.7	M6	22.6/200	20/0.787	-	-	-	S	R	R
XT4	internal	F-P	1x14...1/0	1x2.5...50	9/79.7	slot	5.6/50	15,5/0.61	-	-	-	S	R	R
	internal	F-P	1x4...300	1x25...150	9/79.7	M6	22.6/200	20/0.787	-	-	-	S	R	R
XT4	internal	F-P	1x250...350	1x127...177	not app	M6	25/221	24	-	-	-	S	R	R
XT4 X	internal	F-P	1x14...1/0	1x2.5...50	9/79.7	M6	<8mm ² (8 AWG): 2.3/20.35 ≥8mm ² (8 AWG): 5.6/49.56	16	-	-	-	S	R	R

⁽¹⁾ UL Listed



Internal FCCuAI terminal for copper/aluminum cables



Internal FCCuAI terminal for copper and aluminum cable with take-up of auxiliary voltage



FCCuAI internal terminal with cable

Terminals for flexible busbars - FB

CB	Type of terminal	Vers.	Busbar dimensions MIN [mm/in]			Busbar dimensions MAX [mm]			Tightening [Nm/lb-in]	H Terminal covers [mm/in]			H Separators [mm/in]		
			W	D	Nr	W	D	Nr		Cable or busbar/Terminal	2/0.08	50/1.97	60/2.36	25/0.98	100/3.94
XT1	internal	F-P	10/0.394	0,8/0.031	2/0.078	10/0.394	0,8/0.031	9/0.354	7/61.95	-	R	-	S ⁽¹⁾	R	R
XT2	internal	F-P-W	10/0.394	0,8/0.031	2/0.078	10/0.394	0,8/0.031	9/0.354	7/61.95	-	R	-	S ⁽¹⁾	R	R
XT3	internal	F-P	16/0.629	0,8/0.031	2/0.078	16/0.629	0,8/0.031	10/0.394	14/123.91	-	-	R	S ⁽¹⁾	R	R
XT4	internal	F-P-W	16/0.629	0,8/0.031	2/0.078	16/0.629	0,8/0.031	10/0.394	14/123.91	-	-	R	S ⁽¹⁾	R	R

⁽¹⁾ Phase separators supplied as standard with basic version circuit breaker



Terminal for flexible busbars (FB)



FB terminal with flexible busbars

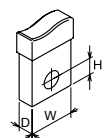

- W** Width
- H** Hole height
- D** Depth
- F** Fixed
- P** Plug-in
- W** Withdrawable
- Ø** Diameter
- S** Standard
- R** On Request

Accessories

Mechanical accessories

3

Multi-cable terminals - MC Cu ⁽¹⁾

CB	Type of terminal	Vers.	Cable		Tightening [Nm/lb-in]		L cable stripping [mm/in]	H Terminal covers [mm/in]			H Phase separators [mm/in]			
			AWG/kcmil	mm ²	Terminal /CB	Cable or busbar /Terminal		2/0.08	50/1.97	60/2.36	25/0.98	100/3.94	200/7.87	
XT1	external	F-P	6x14...2	6x2.5...35	6/53.1	7/61.95	10, 20, 30 / 0.394, 0.787, 1.181	-	S	-	-	-	-	-
XT2	external	F-P-W	6x14...2	6x2.5...35	6/53.1	7/61.95	10, 20, 30 / 0.394, 0.787, 1.181	-	S	-	-	-	-	-
XT3	external	F-P	6x12...2	6x2.5...35	8/70.8	7/61.95	15, 30 / 0.591, 1.181	-	-	S	-	-	-	-
XT4	external	F-P	6x12...2	6x2.5...35	8/70.8	7/61.95	15, 30 / 0.591, 1.181	-	-	S	-	-	-	-

Installation on load side only

⁽¹⁾ UL Listed



Multi-cable terminals (MC)



Multi-cable terminals with cables

Rear horizontal terminals - R

CB	Vers.	Busbar dimensions MAX [mm]				Tightening [Nm/lb-in]				H Terminal covers [mm]			H Separators [mm]		
		W	H	D	Ø	Terminal/CB	Cable or busbar/terminal	2/0.08	50/1.97	60/2.36	25/0.98	100/3.94	200/7.87		
XT1	F	15/0.590	7.5/0.295	5/0.196	6.5/0.255	M5	5/44.2	M6	6/53.1	S	-	-	-	-	-
XT2	F	20/0.787	9/0.354	4/0.157	8.5/0.335	M6	6/53.1	M8	8/70.8	S	-	-	-	-	-
XT3	F	20/0.787	9/0.354	6/0.236	8.5/0.335	M8	8/70.8	M8	8/70.8	S	-	-	-	-	-
XT4	F	20/0.787	9/0.354	6/0.236	8.5/0.335	M8	8/70.8	M8	8/70.8	S	-	-	-	-	-



Rear horizontal terminals (R)



R terminal with horizontal busbar



R terminal with vertical busbar

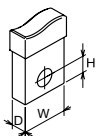

W Width
H Hole height
D Depth

F Fixed
P Plug-in
W Withdrawable
Ø Diameter
S Standard
R On Request

Extended front terminals for fixed part - EF ⁽¹⁾

CB	Vers.	Busbar dimensions [mm/in]			Cable terminals [mm/in]		Tightening [Nm/lb-in]			Phase separators [mm/in]		
		W	D	Ø	W	Ø	Terminal/ CB	Cable or busbar /Terminal	100/3.94	200/7.87		
XT1	P	20/0.787	5/0.197	8.5/0.335	21/0.827	6.5/0.256	M6	6/53.1	M6	9/79.7	S	R
XT2	P-W	20/0.787	5/0.197	8.5/0.335	21/0.827	6.5/0.256	M6	6/53.1	M6	9/79.7	S	R
XT3	P	25/0.984	8/0.315	8.5/0.335	30/1.181	8.5/0.335	M6	8/70.8	M8	18/159.3	S	R
XT4	P-W	25/0.984	8/0.315	8.5/0.335	30/1.181	8.5/0.335	M6	8/70.8	M8	18/159.3	S	R

⁽¹⁾ UL Listed



EF terminals for fixed part

Rear flat horizontal terminals for fixed part - HR

CB	Vers.	Busbar dimensions [mm/in]			Cable terminals [mm/in]		Tightening [Nm/lb-in]			Rear Separators [mm/in]	
		W	D	Ø	W	Ø	Terminal/ CB	Cable or busbar /Terminal	90/3.543		
XT1	P	20/0.787	4	8.5/0.335	20/0.787	8.5/0.335		6/53.1		9/79.7	R
XT2	P-W	20/0.787	4	8.5/0.335	20/0.787	8.5/0.335		6/53.1		9/79.7	R
XT3	P	25/0.984	6	8.5/0.335	25/0.984	8.5/0.335		8/70.8		9/79.7	R
XT4	P-W	25/0.984	10	8.5/0.335	25/0.984	8.5/0.335		8/70.8		9/79.7	R



HR terminals for fixed part

Rear flat vertical terminals for fixed part - VR

CB	Vers.	Busbar dimensions [mm/in]			Cable terminals [mm/in]		Tightening [Nm/lb-in]			Rear Separators [mm/in]	
		W	D	Ø	W	Ø	Terminal/ CB	Cable or busbar /Terminal	90/3.543		
XT1	P	20/0.787	4	8.5/0.335	20/0.787	8.5/0.335		6/53.1		9/79.7	R
XT2	P-W	20/0.787	4	8.5/0.335	20/0.787	8.5/0.335		6/53.1		9/79.7	R
XT3	P	25/0.984	6	8.5/0.335	25/0.984	8.5/0.335		8/70.8		9/79.7	R
XT4	P-W	25/0.984	10	8.5/0.335	25/0.984	8.5/0.335		8/70.8		9/79.7	R



VR terminals for fixed part

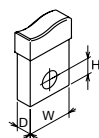

- W** Width
- H** Hole height
- D** Depth
- F** Fixed
- P** Plug-in
- W** Withdrawable
- Ø** Diameter
- S** Standard
- R** On Request

Accessories

Mechanical accessories

3



Terminal covers



Phase barriers

Terminal covers and phase barriers

Terminal covers are applied to the circuit breaker to prevent accidental contact with live parts, thereby providing protection against direct contacts. The terminal covers are pre-punched for knock-outs on the front to facilitate installing busbars and/or cables and ensuring correct insulation.

The phase barrier partitions increase the insulation characteristics between the phases on a level with the connections. They are mounted from the front, even when the circuit breaker has already been installed, by inserting them into the corresponding slots.

The table lists the various terminal covers and phase barriers available for each SACE Tmax XT circuit breaker. The terminal covers/phase barriers that are able to ensure adequate circuit breaker installation and correct insulation are listed in the “Connection terminals” section of this chapter, alongside each terminal.

		XT1	XT2	XT3	XT4
HTC - High terminal covers	[mm/in]	50/1.97	50/1.97	60/2.36	60/2.36
LTC - Low terminal covers	[mm/in]	2/0.08	2/0.08	2/0.08	2/0.08
Phase barrier - low	[mm/in]	25/0.98	25/0.98	25/0.98	25/0.98
Phase barrier - medium	[mm/in]	100/3.94	100/3.94	100/3.94	100/3.94
Phase barrier - high	[mm/in]	200/7.87	200/7.87	200/7.87	200/7.87
Rear phase barrier for FP	[mm/in]	90/3.54	90/3.54	90/3.54	90/3.54

Rotary handle operating mechanism

This device allows the circuit breaker to be operated by means of a rotary handle, which makes the circuit breaker easier to open and close.

Different types of handle are available:

- direct (RHD): installed directly on the front of the circuit breaker. Allows it to be operated from the front;
- extended (RHE): installed on the panel door. Allows the circuit breaker to be operated by means of a rod which acts on a base installed on the front of the circuit breaker;
- side, for lateral left (RHS-L) and lateral right (RHS-R). Allows operation from the side by means of a shaft which acts on the base installed on the front of the circuit breaker.

A long handle grip (LH) which can be combined with the extended handle (RHE) and with the side handle (RHS), is also available.



Direct rotary handle (RHD)



Extended rotary handle (RHE)



(LH) Long handle



(RHS) Side rotary handle

All rotary handles are available in two versions:

- standard: grey color;
- emergency: red on a yellow background. Suitable for operating machine tools.

Rotary handles can be ordered:

- by specifying one single sales code (for RHD, RHE, RHS L/R);
- by indicating the following three devices (only for RHE):
 - rotary handle on compartment door with normal standard handgrip (RHE_H, RHE_H LH) or emergency handgrip (RHE_H_EM, RHE_H_EM LH);
 - 60.5mm/2.38" and 170.5mm/6.71" rod (RHE_S). The minimum and maximum distances between the fixing plate and the door are 60.5mm/2.38" and 170.5mm/6.71";
 - base to fix to the circuit base (RHE_B).

Using the rotary handle is an alternative to the motor operator and to all accessories of the front type. The rotary handles can be locked by means of a vast range of key locks and padlocks (consult the "Locks" section of this chapter).

The direct and extended rotary operating mechanisms allow early contacts to be used on closing in order to supply the undervoltage release in advance of the circuit breaker's closing (consult the "Early auxiliary contacts" section of this chapter).



IP54 protection

IP54 Protection

A device that can be applied onto the transmitted rotary and lateral handle allowing IP54 degree of protection^(G.1.11) to be achieved.



Front for operating lever mechanism

Front for operating lever mechanism

This device can be installed on the front of the circuit breaker, allowing it to be locked with key locks and padlocks.

The front for operating lever mechanism can only be installed on XT2 and XT4 three-pole and four-pole circuit breakers. It can be fitted with a vast range of key locks and padlocks (see the "Locks" section of this chapter).

Accessories

Mechanical accessories



Key lock



Fixed padlock in open position



Fixed padlock in open/closed position



Removable padlock in open position



Key lock/padlock for withdrawable fixed part

Locks

Padlocks or key locks prevent the circuit breaker from being closed and/or opened. They can be fitted:

- directly on the front of the circuit breaker;
- on the rotary handle operating mechanism;
- on the front for lever operating mechanism;
- on the motor;
- to the fixed and withdrawable part, to prevent the moving part from being inserted;
- on the front of the thermomagnetic trip unit, to prevent the thermal part adjustor from being tampered with.

All locks that hold the circuit breaker in the open position ensure circuit isolation in accordance with the IEC 60947-2 Standard. In the closed position, the locks do not prevent the mechanism from releasing after a fault or remote control.



Circuit breaker with removable padlock in open position



Circuit breaker with fixed padlock in open position



Circuit breaker with fixed padlock in open/close position



RHD with key lock



RHE with key lock



FLD with key lock



MOD with key lock



MOE with key lock



Withdrawable fixed part with key lock/padlock

Type of lock		Circuit-breaker	Optional/Standard supply	Position of circuit breaker lock	Type of lock	Removability of key	
Circuit-breaker	PLL Fixed padlock device	XT1...XT4	Optional	OPEN / CLOSED	padlocks max 3 padlocks Ø 7mm stem (not supplied)	–	
		XT1...XT4	Optional	OPEN	padlocks max 3 padlocks Ø 7mm stem (not supplied)	–	
	PLL Removable padlock device	XT1, XT3	Optional	OPEN	padlocks max 3 padlocks Ø 7mm stem (not supplied)	–	
		KLC Key lock ⁽⁵⁾	XT1...XT4	Optional	OPEN	Ronis Same key (A, B, C, D type)	OPEN
	XT1...XT4		Optional	OPEN	Ronis Different key	OPEN	
	XT1...XT4		Optional	OPEN	Ronis Same key	OPEN / CLOSED	
Rotary handle (RHD/RHE/ RHE-LH/ RHS)	RHL Key lock ⁽¹⁾	XT1...XT4	Optional	OPEN	Ronis Same key	OPEN	
		XT1...XT4	Optional	OPEN	Ronis Different key	OPEN	
		XT1...XT4	Optional	OPEN / CLOSED	Ronis Different key	OPEN / CLOSED	
	Padlock device	XT1...XT4	Standard	OPEN	padlocks max 3 padlocks Ø 6mm stem (not supplied)	–	
	Door lock ⁽⁴⁾	XT1...XT4	Standard	DOOR LOCKED WHEN CIRCUIT BREAKER CLOSED	–	–	
Frontal for operating lever (FLD)	Padlock device	XT2, XT4	Standard	OPEN	padlocks max 3 padlocks Ø 6mm stem (not supplied)	–	
	Door lock	XT2, XT4	Standard	DOOR LOCKED WHEN CIRCUIT BREAKER CLOSED	–	–	
		RHL Key lock ⁽¹⁾	XT2, XT4	Optional	OPEN	Ronis Same key	OPEN
			XT2, XT4	Optional	OPEN	Ronis Different key	OPEN
	XT2, XT4	Optional	OPEN / CLOSED	Ronis Different key	OPEN / CLOSED		
Motor (MOD, MOE, MOE-E)	Padlock device	XT1...XT4	Standard	OPEN	padlocks max 3 padlocks Ø 8mm stem (not supplied)	–	
	Key lock on motor MOL-D MOL-S	XT1...XT4	Optional	OPEN	Ronis Different keys	OPEN	
		XT1...XT4	Optional	OPEN	Ronis Same keys	OPEN	
	Key lock against manual operation MOL-M ⁽²⁾	XT1...XT4	Optional	MANUAL	Ronis key	WITH LOCK INSERTED	
Fixed part of withdrawable	KLF-FP Key lock / padlock for fixed part of withdrawable device	XT2, XT4	Optional	Key WITHDRAWN / INSERTED Padlock WITHDRAWN	Ronis key Different + padlocks max 3 padlocks Ø 6mm stem (not supplied)	–	
		XT2, XT4	Optional	Key WITHDRAWN / INSERTED Padlock WITHDRAWN	Ronis key Same + padlocks max 3 padlocks Ø 6mm stem (not supplied)	–	
		XT2, XT4	Optional	Key WITHDRAWN / INSERTED Padlock WITHDRAWN	Giussani key Different + padlocks max 3 padlocks Ø 6mm stem (not supplied)	–	
		XT2, XT4	Optional	Key WITHDRAWN / INSERTED Padlock WITHDRAWN	Giussani key Same + padlocks max 3 padlocks Ø 6mm stem (not supplied)	–	
Trip unit	Lock of thermal regulation ⁽³⁾	XT1, XT3	Optional	–	–	–	
		XT2, XT4	Standard	–	–	–	

⁽¹⁾ On the transmitted rotary handle (RHE), the lock is mounted on the base. The key lock is not available on the lateral handle (RHS).

⁽²⁾ Only for MOE and MOE-E.

⁽³⁾ Applied to the cover of the circuit breakers on a level with the regulator of the thermal element of thermomagnetic release TMD to prevent it from being tampered with.

⁽⁴⁾ This function can be totally inhibited by the customer when the handle is assembled by means of a simple operation that can be reversed if needed.

Moreover, if the door lock function is not disabled by the customer during the assembly phase, the door lock can be temporarily deactivated with a tool in exceptional cases, so that the door can be opened without opening the circuit breaker .

⁽⁵⁾ Incompatible with electrical accessories mounted in the third pole.

Accessories

Mechanical accessories

3



Interlock

Rear mechanical interlock

Support designed for rear installation of two circuit breakers that, through connections, prevents the two installed breakers from closing simultaneously.

The circuit breakers in the Tmax XT family are interlocked two-by-two (IO-OI-OO) by means of a chassis and special plates. Interlocked circuit breakers can be of a fixed, plug-in or withdrawable version. Both circuit breakers and molded case switch disconnectors in the three-pole and four-pole versions can be interlocked.

Acceptable combinations are:

	XT1	XT2	XT3	XT4
XT1	■	■	■	■
XT2	■	■		■
XT3	■		■	
XT4	■	■		■

The following equipment must be ordered to make the rear interlock:

- a vertical or horizontal chassis;
- a plate for each circuit breaker to be interlocked.



Interlock - Chassis

Two Plates

Interlock



Bracket for fixing on DIN rail

Bracket for fixing on DIN rail

Support designed to be installed on the back of the circuit breakers to simplify assembly on standardized DIN EN 50022 rail.

The following can be installed on DIN EN 50022 rail:

- all Tmax XT circuit breakers in the fixed three-pole or four-pole versions;
- XT1, XT3 circuit breakers equipped with RC Sel 200; RC Inst, RC Sel for XT1 and XT3 residual current releases.

Flanges

A flange is a plastic plate that acts as an interface between the circuit breaker and the hole in the panel door. All the Tmax XT series flanges are newly designed and do not require screws for installation. Flanges are applied:

- around the front part of the fixed/plug-in circuit breaker;
- around the operating lever for all fixed/plug-in/circuit breakers;
- around the MOD or MOE motor operator;
- around the front for FLD locks;
- around the direct rotary handle operating mechanism;
- around the extended rotary handle operating mechanism;
- around the RC Inst, RC Sel for XT1 and XT3, RC Sel for TX2 and TX4 residual current release.



XT1-XT3
with standard flange



XT2-XT4
with standard flange



XT1-XT4
with operating lever
flange



Rotary handle
with flange



MOE
with flange



MOD
align flush left
under MOD

Accessories

Electrical accessories

3

Tmax XT UL/CSA electrical accessories		UL Listed	XT1	XT2	XT3	XT4
Shunt opening release	SOR / SOR-C (uncabled and cabled)	■	■	■	■	■
Undervoltage release	UVR / UVR-C (uncabled and cabled)	■	■	■	■	■
Time-delay device for undervoltage release	UVD	-	■	■	■	■
Cabled auxiliary contacts, 1m	1 Q 1 SY 24V DC	■	■	■	■	■
Q: signaling contact open/closed	3 Q 1 SY 24V DC	■	-	■	■	■
	1 S51 24V DC	■	-	■	-	■
SY: trip position signaling contact	1 Q 1 SY 250V AC/DC	■	■	■	■	■
	2 Q 2 SY 1 S51 250V AC/DC	■	-	■	-	■
S51: signaling contact due to trip unit tripping or interaction	3 Q 2 SY 250V AC/DC	■	-	■	-	■
	3 Q 1 SY 250V AC/DC	■	-	■	■	■
	1 S51 250V AC/DC	■	-	■	-	■
	3 Q on left 250V AC/DC	■	■	■	■	■
	2 Q 1 SY 250V AC/DC	■	■	■	■	■
	1 Q 1 SY 400V AC	■	-	■	-	■
	2 Q 400V AC	■	-	■	-	■
	24V DC	■	■	■	■	■
Uncabled auxiliary contacts	S51 24V DC	■	-	■	-	■
	250V AC/DC	■	■	■	■	■
	S51 250V AC/DC	■	-	■	-	■
Auxiliary position contacts	AUP - Inserted (24V and 250V)	■	■	■	■	■
	AUP - Withdrawn (24V and 250V)	■	-	■	-	■
Early auxiliary contacts in the rotary handle	AUE - 2 contacts closed	■	■	■	■	■
	AUE - 2 contacts open	■	■	■	■	■
Motor operators	MOD	■	■	-	■	-
	MOE	■	-	■	-	■
	MOE-E	-	-	■	-	■
Residual current devices	RC Inst	-	■	-	■	-
	RC Sel 200	-	■	-	-	-
	RC Sel for XT1 XT3	-	■	-	■	-
	RC Sel for XT2 XT4	-	-	■	-	■
	RC B Type	■	-	-	■	-
Ekip electronic trip unit accessories	Ekip Display	-	-	■	-	■
	Ekip LED Meter	-	-	■	-	■
	Ekip Com	-	-	■	-	■
	HMI030 interface on the front of the switchboard	-	-	■	-	■



Cabled SOR - UVR



Cabled SOR - UVR for withdrawable circuit breaker



Uncabled SOR - UVR

Service releases

Shunt opening release (SOR). Allows the circuit breaker to be opened by means of a non-permanent electrical control. Release operation is ensured for voltages between 70% and 110% of the rated power supply voltage U_n , in both alternating and direct current. The SOR is equipped with a built-in limit contact to shut off the power supply in the open position with the relay tripped.

A remote controlled emergency opening command can be created by connecting an opening button to the SOR.

Undervoltage release (UVR). Allows the circuit breaker to open when the release is subjected to either a power failure or a voltage drop. Opening is ensured when the voltage is between 70% and 35% of the rated power supply U_n . After tripping, the circuit breaker can be closed again if the voltage exceeds 85% of U_n . When the undervoltage release is not energized, neither the circuit breaker nor the main contacts can be closed. A remote controlled emergency opening command can be created by connecting an opening button to the UVR.

None of the service releases in the Tmax XT series requires screws for installation. They are extremely easy to fit. Just use slight pressure to snap the release into the appropriate place. All service releases are available in two versions:

- cabled (AWG20 cable section - 0.5mm²):
 - for fixed/plug-in circuit breakers with 1m long cables;
 - for withdrawable circuit breakers with fixed part and moving part connector;
- not cabled:
 - for fixed/plug-in circuit breakers with cables from (1.5 mm²/14 AWG in section).

In circuit breakers:

- three-pole: either one SOR or one UVR can be installed in the slot on the left of the operating lever;
- four-pole: two service releases can be installed at the same time by using the third and fourth poles. If the circuit breaker is the withdrawable type, the connector for the fourth pole must be ordered to be able to install an SOR or UVR in the fourth pole.



SOR Electrical specifications

Version	Max power absorbed on inrush	
	AC [VA]	DC [W]
12V DC		50
24-30V AC/DC	50	50
48-60V AC/DC	60	60
110...127V AC-110...125V DC	50	50
220...240V AC-220...250V DC	50	50
380-440V AC	55	
480-525V AC	55	

UVR Electrical specifications

Version	Power absorbed during normal operation	
	AC [VA]	DC [W]
24-30V AC/DC	1.5	1.5
48V AC/DC	1	1
60V AC/DC	1	1
110...127V AC-110...125V DC	2	2
220...240V AC-220...250V DC	2.5	2.5
380-440V AC	3	
480-525V AC	4	

Accessories

Electrical accessories



Time delay device for undervoltage release

3

Time delay device for undervoltage release (UVD)

The undervoltage release (UVD) can be combined with an external electronic power supply time delay. This allows the circuit breaker opening to be delayed with preset and adjustable timing if the power supply voltage of the release either drops or fails, thus preventing untimely tripping caused by temporary faults. The time delay must be used with the undervoltage release (UVR) of the corresponding voltage.

A remote control positive safety opening command can be created by connecting an opening pushbutton to the UVR combined with the UVD.

UVD - Electrical specifications

Power supply Voltage [V]	24...30V AC/DC
	48...60V AC/DC
	110...125V AC/DC
	220...250V AC/DC
Settable delay [s]	0.25 - 0.5 - 0.75 - 1 - 1.25 - 2 - 2.5 - 3
Opening time tolerance	±15%

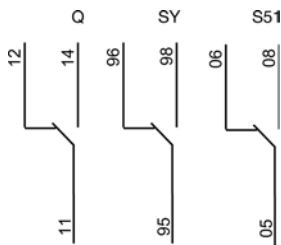

Auxiliary contacts

Contacts which allow information about the operating state of the circuit breaker to be routed outside the circuit breaker. The following information is available:

- open/closed: indication of the position of the circuit breaker power contacts (Q);
- trip: signaling circuit breaker opening due to the current release tripping (owing to overload or short-circuit), opening or undervoltage releases, emergency opening pushbutton of the motor operator, or use of the test button (SY);
- trip unit tripping: indicates that one of the protection functions of the electronic or thermomagnetic trip unit has tripped (S51).

Changeover of auxiliary contacts Q (open/closed), SY (relay tripped) and S51 (trip unit tripping)

Normal sequence	CB Open	Q=12	SY=96	S51=06
	CB Closed	Q=14	SY=96	S51=06
Trip sequence (trip caused by: SOR, UVR, trip test)	CB Open	Q=12	SY=96	S51=06
	CB Closed	Q=14	SY=96	S51=06
	CB Trips	Q=12	SY=98	S51=06
	CB Resets	Q=12	SY=96	S51=06
Trip sequence (trip caused by trip unit)	CB Open	Q=12	SY=96	S51=06
	CB Closed	Q=14	SY=96	S51=06
	CB Trips	Q=12	SY=98	S51=08
	CB Resets	Q=12	SY=96	S51=06

24V DC and 250V AC/DC auxiliary contacts



Cabled auxiliary contact



Uncabled auxiliary contact



Cabled auxiliary contact for withdrawable circuit breaker

250V AC/DC and 24VAC/ DC auxiliary contacts are installed without the need for screws. They are extremely easy to fit. Simply use slight pressure to snap the auxiliaries into the appropriate place. The following versions of auxiliary contacts are available:

- cabled (AWG20 cable section - 0.5mm²):
 - for fixed/plug-in circuit breakers with 1m long cables;
 - for withdrawable circuit breakers with fixed part and moving part connector;
- heavy duty cabled (AWG20 cable section - 0.5mm²):
 - for applications requiring cable capacity to 600V;
 - for fixed/plug-in circuit breakers with 1m long cables;
 - for withdrawable circuit breakers with fixed part and moving part connector;
- not cabled:
 - for fixed/plug-in circuit breakers with cables from 0.5 up to 1.5 mm² in section.

Auxiliary contacts are supplied for each circuit breaker in the SACE XT family in various combinations, as shown in the table. The following items can be ordered to make installation even more flexible:

- a non-cabled auxiliary contact can create different signals (Q or SY) based on its position within the circuit breaker;
- a non-cabled S51 auxiliary contact, which can be used for XT2 or XT4 circuit breakers;
- a cabled auxiliary contact, with non numbered cables. By changing the placement in the circuit breaker, it's possible to obtain different signals (Q or SY).

This version is available with standard cables and with a heavy duty (600V) cable option.

Accessories



Electrical accessories

3

Combinations of cabled auxiliary contacts with numbered cables	XT1	XT2	XT3	XT4
	3/4p	3/4p	3/4p	3/4p
1 Q + 1 SY 24V DC ⁽¹⁾	F-P	F-P-W	F-P	F-P-W
3 Q + 1 SY 24V DC	–	F-P-W	F-P	F-P-W
1 S51 24V DC	–	F-P-W	–	F-P-W
1 Q + 1 SY 250V AC/DC ⁽¹⁾	F-P	F-P-W	F-P	F-P-W
2 Q + 2 SY + 1 S51 250V AC/DC	–	F-P-W	–	F-P-W
3 Q + 2 SY 250V AC/DC	–	F-P-W	–	F-P-W
3 Q 1 SY 250V AC/DC	–	F-P-W	F-P	F-P-W
1 S51 250V AC/DC	–	F-P-W	–	F-P-W
3 Q on left 250V AC/DC	F-P	F-P	F-P	F-P
2 Q + 1 SY 250V AC/DC	F-P	F-P	F-P	F-P

F = Fixed, P = Plug-in, W = Withdrawable
 (1) Available in standard and HD versions

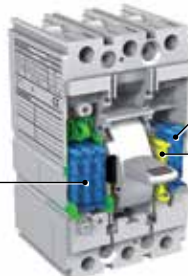
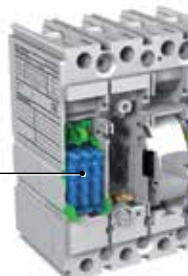
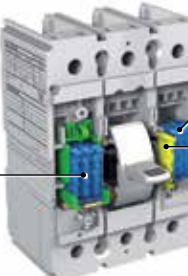
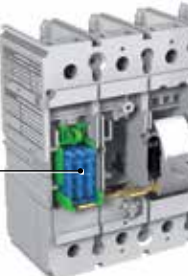
Auxiliary contacts 24V DC - 250V AC/DC

	Circuit breaker 3p	Circuit breaker 4p
XT1	 <p>3 Q on Left</p> <p>2 Q</p> <p>1 SY</p>	 <p>3 Q on Left</p> <p>2 Q</p> <p>1 SY</p>
XT3	 <p>3 Q on Left</p> <p>3 Q</p> <p>1 SY</p>	 <p>3 Q on Left</p> <p>3 Q</p> <p>1 SY</p>
XT2 XT4	 <p>3 Q on Left</p> <p>2 SY</p> <p>2 Q</p> <p>1 S51 or 1 Q</p>	 <p>3 Q on Left</p> <p>2 SY</p> <p>2 Q</p> <p>1 S51 or 1 Q</p>

AUX 250V AC/DC - Electrical specifications

Power supply Voltage [V]	Class of use ^(G2,16)	Operating current [A]	
		AC	DC
110 AC/DC	DC-12	–	0.5
	DC-13 and DC-14	–	0.05
125 AC	AC-12, AC-13, AC-14	6	–
	AC-15	5	–
250 AC/DC	AC-12 and DC-12	6	0.3
	AC-13 and DC-13	6	0.03
	AC-14 and DC-14	5	0.03
	AC-15	4	–

AUX 24V DC - Electrical specifications

Power supply Voltage [V]	Operating current [A]
	DC
5 DC	0.01
24 DC	0.1

400V AC auxiliary contacts

400V AC auxiliary contacts are only available for XT2 and XT4 circuit breakers in the following versions:

- cabled (AWG17 cable section - 1mm²):
 - for fixed/plug-in circuit breakers with 1m long cables;
 - for withdrawable circuit breakers with fixed part and moving part connector.

The 400V auxiliary contacts take up the whole right-hand slot of the circuit breaker.



Cabled auxiliary contact



Cabled auxiliary contact for withdrawable circuit breaker

Combinations	XT1	XT2	XT3	XT4
	3/4p	3/4p	3/4p	3/4p
1 Q + 1 SY 400V	–	F-P-W	–	F-P-W
2 Q 400V	–	F-P-W	–	F-P-W

F = Fixed, P = Plug-in, W = Withdrawable

Auxiliary contacts 400V AC

	Circuit breaker 3p	Circuit breaker 4p
XT2 XT4		

Accessories

Electrical accessories

3



Auxiliary position contact

AUX 400V AC - Electrical specifications

Power supply Voltage [V]	Class of use (G2.16)	Operating current [A]	
		AC	DC
125 DC	DC-13 and DC-12	–	0.5
250 AC/DC	AC-13 and AC-14	12	–
	DC-12 and DC-13	–	0.3
400 AC	AC-13 and AC-14	3	–

Auxiliary position contacts - AUP

These contacts allow information about the position of the circuit breaker relative to the fixed part of plug-in or withdrawable versions to be routed outside the circuit breaker itself.

Two types of position contact (AUP) are available, at 250V AC/DC and 24V AC/DC:

- racked-in contact for all plug-in and withdrawable SACE Tmax XT circuit breakers, to be positioned in the fixed part;
- racked-out contact for all withdrawable SACE Tmax XT2 and XT4 circuit breakers, to be installed in the side part of the withdrawable version.

For further details about the electrical specifications of the contacts, consult the “24V DC and 250V AC contacts” section of this chapter.

Circuit breaker		N° racked-in contact	N° racked-out contact
XT1	3/4 poles	4	–
XT2	3 poles	2	2
	4 poles	4	
XT3	3/4 poles	4	–
XT4	3/4 poles	4	2

Plug-in circuit breaker with racked-in contact

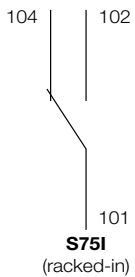

S75I=104

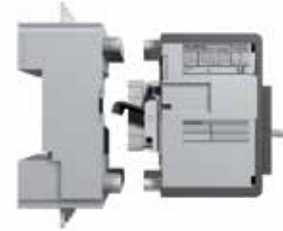

S75I=102

Withdrawable circuit breaker with racked-in/racked-out contacts

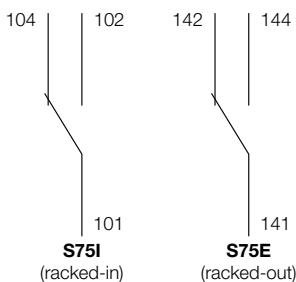

S75I=102
S75E=144



S75I=102
S75E=142



S75I=104
S75E=142



Early auxiliary contacts in the handle

Early make/break auxiliary contacts - AUE

Early contacts in relation to **closing (early/make)**: allow the undervoltage release to be supplied before the main contacts close, in accordance with the IEC 60204-1, VDE 0113 Standards.

Early contacts in relation to **opening (early/break)**: allow any electronic devices connected to the system that could be damaged owing to overvoltages generated by the circuit breaker opening operation to be disconnected in advance.

The early opening/closing auxiliary contacts can be installed inside the direct and extended rotary handle operating mechanisms for all the SACE Tmax XT circuit breakers (max two contacts @ 400V):

- in the cabled version with 1m long cables (AWG20 cable sections);
- a dedicated code is available in the withdrawable version which includes the connector for the moving part and fixed part.

For further details about the electrical specifications of the contacts, consult the "400V DC contacts" section of this chapter.

Motor operators

Devices that allow circuit breaker opening and closing to be controlled:

- in the remote mode, by means of electric controls;
- locally, directly from the front, by means of special mechanisms.



Direct action motor operator (MOD)

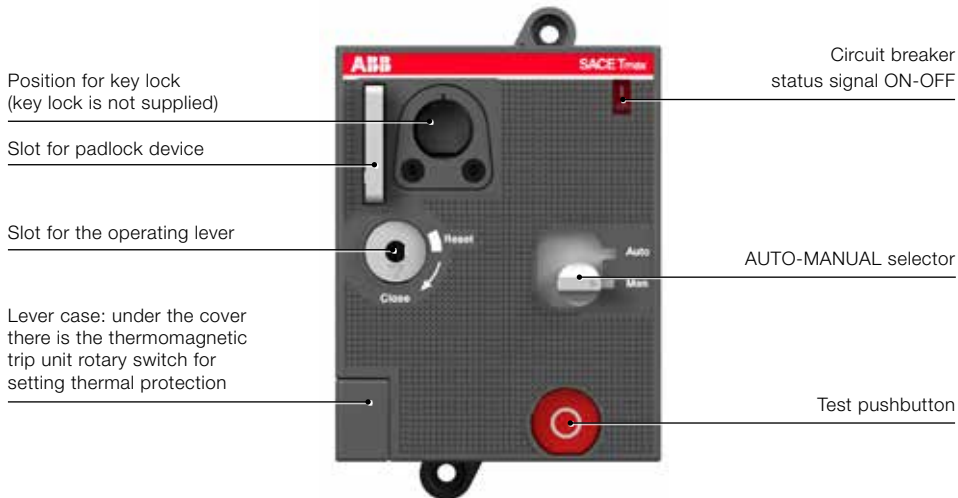

MOD direct action motor operator

The direct action motor control is available for XT1 and XT3 and is supplied:

- complete with 1m long cables;
- with flange, to replace the standard one supplied with the circuit breaker;
- with padlock device, only removable when the motor is in the open position. The padlock device accepts up to three 8mm/0.31in padlocks;
- auxiliary contacts (AU-MO) which allow the motor control mode (manual or auto) signal to be routed outside;
- (on request) the motor operator can be fitted with a key lock (consult the "Locks" section of this chapter).

Accessories

Electrical accessories

3

Operating principles:

- a selector on the front of the MOD is used for selecting the operating mode:
 - AUTO: when the selector is in this position, circuit breaker closing can only take place remotely by means of an electric impulse, whereas opening is allowed both remotely and from the front of the motor;
 - MANUAL: when the selector is in this position, the circuit breaker can only be opened/closed from the front of the motor by means of the corresponding lever housed in a slot made in the motor itself;
- operation of the motor operator via remote control is also ensured by permanent electrical opening/closing impulses;
- the resetting modes shown in the diagrams below depend on the reset wiring diagram chosen by the customer (consult the reset wiring diagrams in the “Electric diagrams”) chapter.

Operating mode: Manual

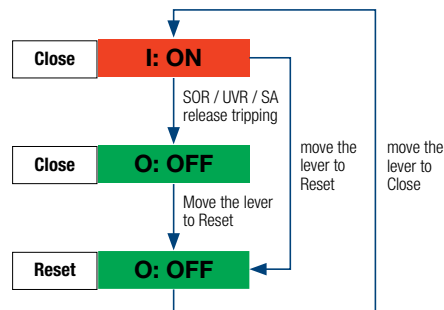

Operating mode: Auto

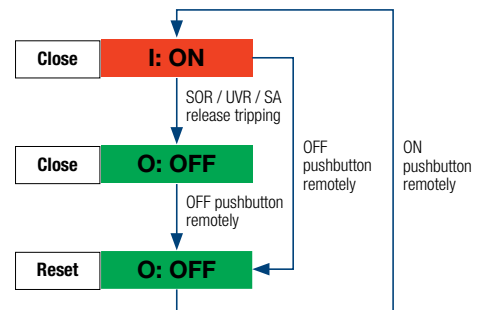

Stored energy motor operators (MOE)

Stored energy motor operators - MOE and MOE-E



The MOE or MOE-E stored energy motor operator is available for XT2 and XT4 and is supplied:

- complete with 1m long cables;
- complete with connector for the fixed part and moving part of withdrawable devices. If the motor operator is used with fixed or plug-in circuit breakers, the connector can be easily removed;
- with flange, to use instead of the standard one supplied with the circuit breaker;
- with padlock device, only removable when the motor is in the open position. The padlock device accepts up to three 8mm/0.31in padlocks;
- with lock of the AUTO-MANUAL selector;

- with auxiliary contacts (AUX-MO) that allow the motor's control mode (manual or remote) signal to be routed outside;
- (on request) the motor operator can be fitted with a key lock (consult the "Locks" section in this chapter);
- (on request) the motor operator can be equipped with a lock to safeguard against manual operation MOL-M (consult the "Locks" section in this chapter).

Operating principles:

- a selector on the front of the MOE, is used for selecting the operating mode:
 - AUTO: when the selector is in this position, the pushbuttons on the front of the motor are locked. Circuit breaker closing can only take place remotely by means of an electric impulse, whereas opening is allowed both remotely and from the front of the motor;
 - MANUAL: the circuit breaker can only be opened/closed from the front of the motor using the appropriate pushbuttons;
 - LOCKED: when the selector is in this position, the circuit breaker is in the open position. The padlock device can be withdrawn and the motor locked in the open position;
- operation of the motor operator via remote control is also ensured by permanent electrical opening/closing impulses. Once an opening command has been given, the next closing command (permanent) is taken over by the motor operator once opening has been completed. Likewise, an opening command is taken over once the previous closing operation has been completed;
- the resetting modes shown in the diagrams below depend on the reset wiring diagram chosen by the customer (consult the reset wiring diagrams in the "Electric diagrams" chapter).

If the electronic trip unit (Ekip LSI, Ekip LSIG or Ekip E-LSIG) with Ekip Com module is used, motor operator MOE-E can be used instead of motor operator MOE.

MOE-E allows the digital signals from the monitoring system to be used by means of the release and Ekip Com contacts and to be converted into power signals for operating the motor operator. All the features described above for the MOE motor operator are also valid for the MOE-E version.

Operating mode: Manual

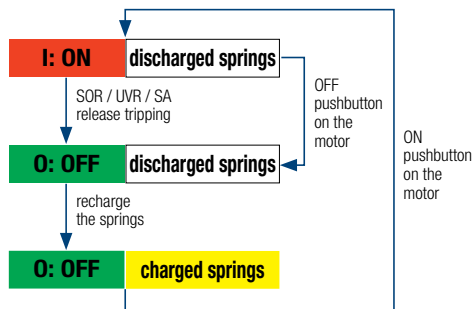

Operating mode: Auto

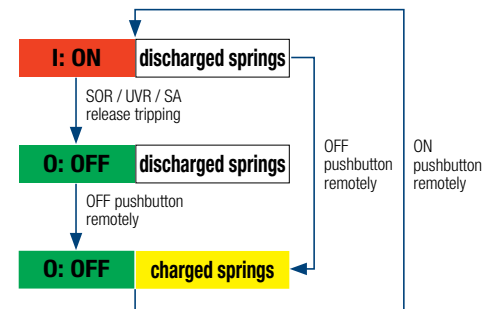

Accessories

Electrical accessories

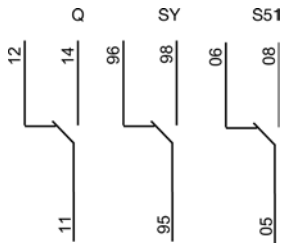

3

Changeover of auxiliary contacts Q (open/closed), SY (relay-tripped) and S51 (trip unit tripping)

Circuit breaker with MOE (MANUAL Mode)

Normal sequence	CB Closed	Q=14	SY=96	S51=06
	By pressing the Red pushbutton, the CB trips	Q=12	SY=98	S51=06
	Charging the springs, CB opens	Q=12	SY=96	S51=06
	By pressing the Green pushbutton, the CB Closes	Q=14	SY=96	S51=06
Trip sequence (trip caused by: - SOR, - UVR, - trip test)	CB Closed	Q=14	SY=96	S51=06
	CB trips	Q=12	SY=98	S51=06
	Charging the springs, CB opens	Q=12	SY=96	S51=06
	By pressing the Green pushbutton, the CB Closes	Q=14	SY=96	S51=06
Trip sequence (trip caused by trip unit)	CB Closed	Q=14	SY=96	S51=06
	CB trips	Q=12	SY=98	S51=08
	Charging the springs, CB opens	Q=12	SY=96	S51=06
	By pressing the Green pushbutton, the CB Closes	Q=14	SY=96	S51=06

Circuit breaker with MOE (AUTO Mode)

Normal sequence	CB Closed	Q=14	SY=96	S51=06
	By pressing the Opening pushbutton remotely, the CB opens	Q=12	SY=98	S51=06
	By pressing the Closing pushbutton remotely, the CB Closes	Q=14	SY=96	S51=06
Trip sequence (trip caused by: - SOR, - UVR, - trip test)	CB Closed	Q=14	SY=96	S51=06
	CB trips	Q=12	SY=98	S51=06
	By pressing the Opening pushbutton remotely, the CB opens	Q=12	SY=96	S51=06
	By pressing the Closing pushbutton remotely, the CB Closes	Q=14	SY=96	S51=06
Trip sequence (trip caused by trip unit)	CB Closed	Q=14	SY=96	S51=06
	CB trips	Q=12	SY=98	S51=08
	By pressing the Opening pushbutton remotely, the CB opens	Q=12	SY=96	S51=06
	By pressing the Closing pushbutton remotely, the CB Closes	Q=14	SY=96	S51=06

Electrical specifications

		MOD	MOE and MOE-E		
Rated voltage, Un	[V]	–	24 DC		
	[V]	–	48...60 DC		
	[V]	110...125 AC	110...125 DC	110...125 AC	110...125 DC
	[V]	220...250 AC	220...250 DC	220...250 AC	220...250 DC
	[V]	380...440 AC	–	380...440 AC	–
	[V]	480...525 AC	–	480...525 AC	–
Operating Voltage	[% Un]	MIN=85% Un; MAX=110% Un			
Power absorbed on inrush Ps	[VA - W]	≤ 500	≤ 500	≤ 300	≤ 300
Power absorbed in Pc service	[VA - W]	≤ 300	≤ 300	≤ 150	≤ 150
Operating frequency	[Hz]	50..60		50..60	
Duration ⁽¹⁾	CL → OP [s]	< 0.1		< 1.5	
	OP → CL [s]	< 0.1		< 0.1	
	TR → OP [s]	< 0.1		< 3	
Mechanical life	[N° operations]	25000		25000	
Minimum duration of electrical opening and closing command	[ms]	≥ 150		≥ 150	

⁽¹⁾ Total time, from transmission of impulse to opening/closing of circuit breaker

Connectors for electrical accessories

Plug-in circuit breaker

In the plug-in version of SACE Tmax XT circuit breakers, the auxiliary circuits can be disconnected by means of two different types of adapter:

- plug and socket adapter to be fixed on the bottom of the panel: for XT1, XT2, XT3, XT4;
- plug and socket adapter installed on the rear of the circuit breaker and in the fixed part of plug-in devices: for XT2, XT4.



Plug and socket adapters on the back of the panel



Plugged and socket adapter placed on the back moving part



Plug and socket adapter in the fixed part



Cabling of withdrawable version

Plug and socket adapters on the panel

To make it easier to connect/disconnect auxiliary circuits, wired electrical accessories can be connected to one or more plug and socket connectors to be installed on the back of the panel.

3, 6, 9 and 15-PIN connectors are available. The cables connect/disconnect to and from the connector quickly and easily without any special tools.

Consider the number of cables each electrical accessory requires when calculating the number of connectors needed.

Accessory	Number of cables
SOR, UVR, External Neutral	2
1 AUX	3
AUE	4
MOE-E	5
Ekip Com	6
MOE (with AUX-MO), MOD (with AUX-MO)	7

Plug and socket adapters installed on the rear of the circuit breaker and in the fixed part

Only for the plug-in versions of Tmax XT2 and XT4 circuit breakers can the auxiliary circuits be automatically disconnected. This is accomplished by an adapter installed on the rear of the circuit breaker and in the fixed part of the plug-in version.

The 12-PIN connector can only be used with accessories that function at a voltage not exceeding 250V AC/DC. Cables are connected to/disconnected from the connector quickly and easily with no special tools required. Wiring is to be carried out by the customer.

Withdrawable circuit breaker

When withdrawable circuit breakers are used, the codes of the electrical accessories specifically designed for this version must be ordered. These dedicated codes contain the wired electrical accessory with connector for both the moving and the fixed parts to be inserted in the side of the fixed part. If the MOE motor operator is ordered, connectors for the fixed part and moving part are always supplied since there is no dedicated code for the withdrawable version.

Electrical accessory connectors for withdrawable circuit breakers must all be installed in housings on the right-hand side of their fixed part. This type of connection allows for automatic disconnection of auxiliary circuits when the circuit breaker is withdrawn from the fixed part. If the customer wants to wire the fixed part in advance of the moving part, mounting connectors for the fixed part can be ordered as spare parts.

Residual current releases

Both circuit breakers and switch-disconnectors are pre-engineered for assembly combined with residual current releases.

Residual current circuit breakers, derived from the circuit breaker, are known as "mixed". In addition to protecting against circuit breakers' typical overloads and short circuits, they also protect people against ground fault currents. This, in turn, protects against direct and indirect contact and the risk of fire.

Residual current circuit breakers, derived from the switch-disconnector, known as "pures". They only provide residual current protection and not the protections typical of circuit breakers. "Pures" are only sensitive to ground fault current and are generally used as main switches in small panels for distribution to end users.

Using "pure" and "mixed" residual current circuit breakers allows for continuous monitoring of the installation's insulation status. It ensures effective protection against the risk of fire, explosion and, in the case of detecting fault at $I_{\Delta n} < 30\text{mA}$ devices, also protects people against indirect and direct contacts, incorporating compulsory measures established by the accident prevention standards and regulations.

The residual current releases comply with the following Standards:

- IEC 60947-2 annex B;
- IEC 61000: for protection against unwarranted tripping.

The table shows all the residual current devices that can be used with the Tmax XT family of circuit breakers:

	XT1		XT2		XT3		XT4	
	3p	4p	3p	4p	3p	4p	3p	4p
RC Inst	F	F			F	F		
RC Sel XT1-XT3	F	F			F	F		
RC Sel 200		F						
Rc Sel XT2-XT4				F-P-W				F-P-W
RC B type						F		

F = Fixed, P = Plug-in, W = Withdrawable

All Tmax XT residual current devices:

- feature microprocessor technology and act directly on the circuit breaker by means of a dedicated opening solenoid (supplied with the residual current release and also available as a spare part) which must be housed in the corresponding slot in the third pole left of the operating lever;
- do not need an auxiliary supply; they are powered directly from the mains;
- can be supplied either from above or below;
- functionality is ensured even with a single phase plus neutral or just two live phases and in the presence of pulsating unidirectional currents with direct components (minimum auxiliary voltage PHASE-NEUTRAL 85 Vrms);
- all possible connection combinations are permitted, as long as the neutral connection to the first pole on the left in the four-pole version is ensured.

RC Sel 200 residual current releases (type A) XT1

Thanks to its low height, the RC Sel 200 residual current release can be installed in 200mm modules. Its special shape also reduces the installation's footprint if two or more units are to be installed side by side.



RC Inst residual current releases for XT1 and XT3

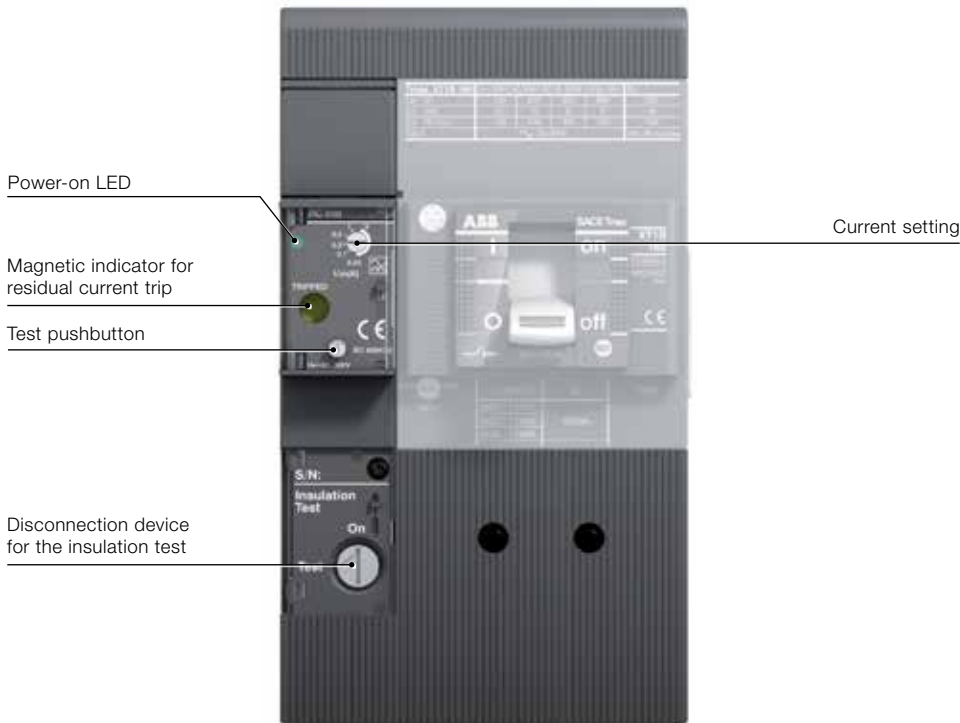

Accessories

Electrical accessories

3

RC Sel residual current releases (type A) for XT1 and XT3

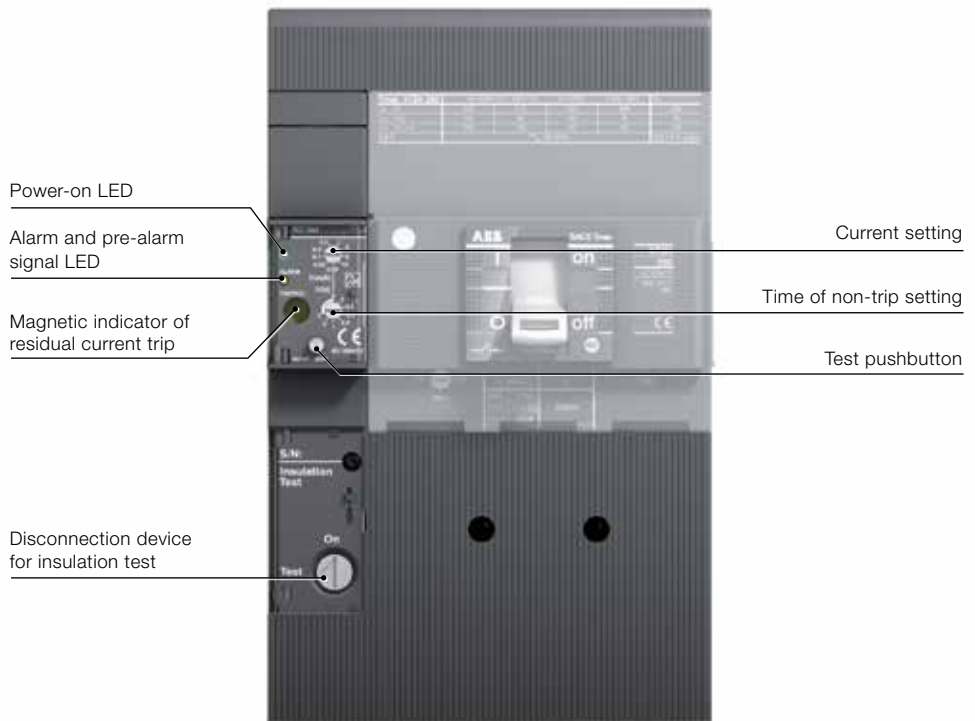

With RC Inst and RC Sel residual current release for XT1 - XT3, available only in Fixed version, it is possible to have rear terminal connection, by ordering RC Rear terminals 4p kits.

RC Sel residual current releases (type A) for XT2 and XT4

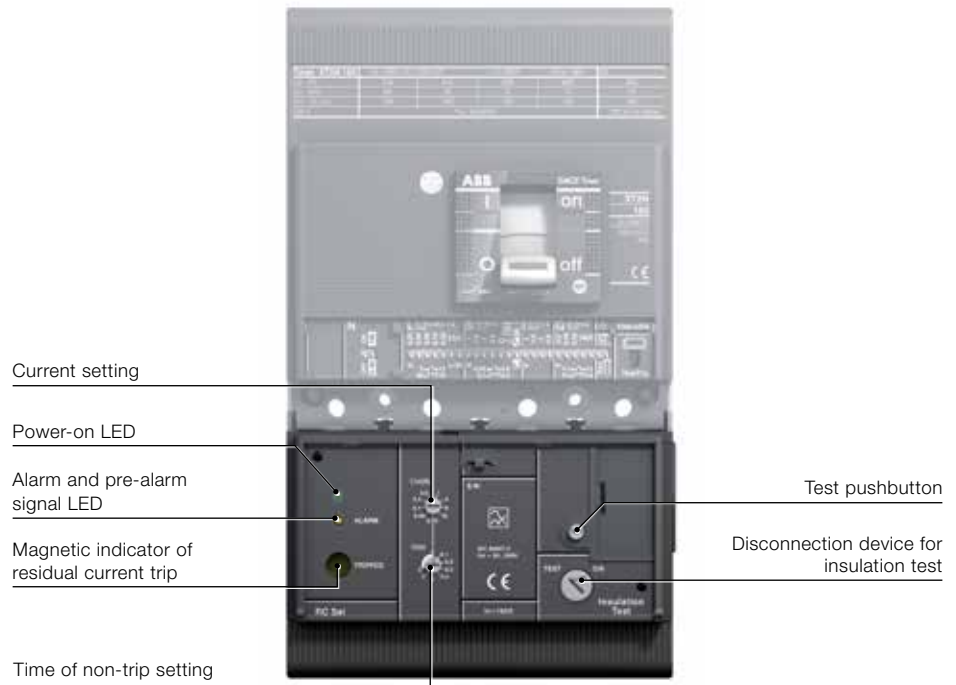

The fixed version of the RC Sel residual current release can easily be converted:

- into the plug-in type:
 - by ordering the kit for converting the residual current release from the fixed to the plug-in version;
- into the withdrawable type:
 - by ordering the kit for converting the residual current release from the plug-in to the withdrawable version. This kit contains the shunt opening release of the withdrawable residual current device to replace the one supplied with the fixed version. The shunt opening release of the withdrawable residual current device contains connectors for both the moving and fixed parts. The 160A frame with residual current withdrawable breaker can be used up to a maximum current of 135A; the 250A frame can be used up to 210A.

With the RC Sel residual current release for XT2-XT4, it is possible to use the same terminals for the fixed circuit breaker and for the fixed parts of plug-in and withdrawable circuit breakers.

RC B Type residual current release (type B) for XT3

The RC B Type residual current release, to be used in conjunction with the XT3 circuit breaker,

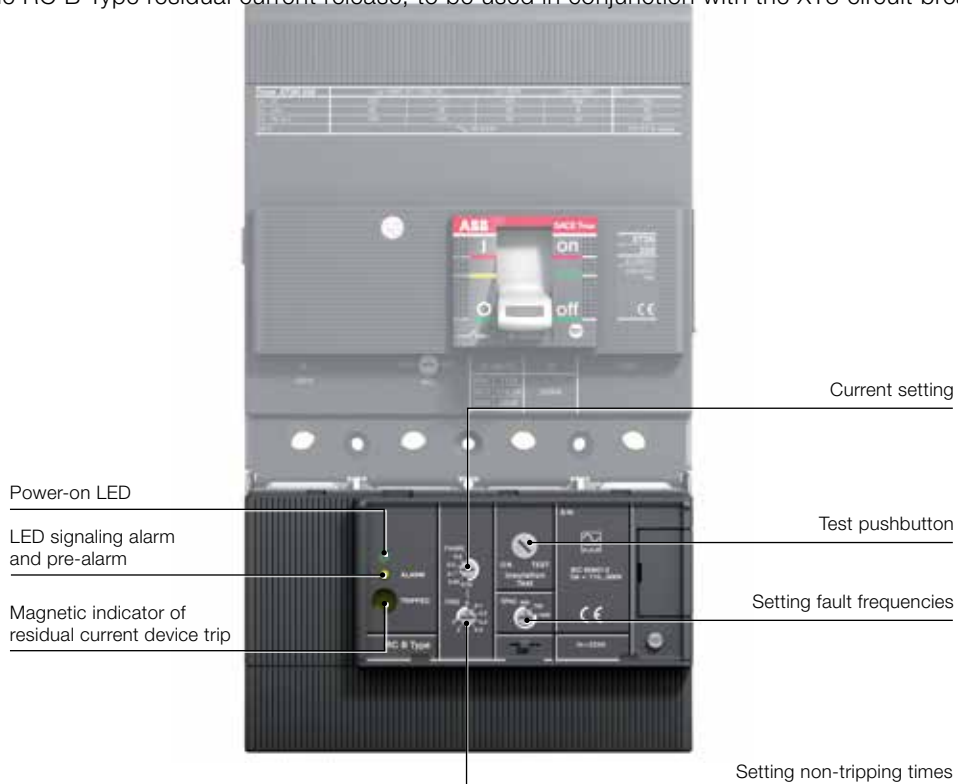

has the following features:

- it complies with type B operation, which guarantees sensitivity to residual fault currents with alternating, pulsating alternating and direct current components (IEC 60947-1, IEC 60947-2 Annex B, IEC 60755);
- the maximum frequency band of the residual fault current can be selected (3 steps: 400 - 700 - 1000Hz). The residual current device can therefore be adapted to suit various industrial installation requirements according to the prospective fault frequencies generated on the load side of the release. Typical installations that may require different frequency thresholds from the standard ones (50 - 60Hz) are welding systems for the automobile industry (1000Hz), the textile industry (700Hz), airports and three-phase drives (400Hz)
- UL Listed.

Accessories

Electrical accessories

3

Electrical characteristic	Residual current devices				
	RC Sel 200mm XT1	RC Inst XT1-XT3	RC Sel XT1-XT3	RC Sel XT2-XT4	RC B Type XT3
Primary power supply Voltage [V]	85...690	85...690	85...690	85...690	110...500
Operating frequency [Hz]	45...66	45...66	45...66	45...66	45...66
Fault frequency [Hz]	50-60	50-60	50-60	50-60	400-700-1000
Test operating range [V]	85...500	85...500	85...500	85...690	110...500
Rated operating current [A]	up to 160	XT1 up to 160 XT3 up to 250	up to 160 XT1 up to 250 XT3	up to 160 XT2 ⁽²⁾ up to 250 XT4 ⁽²⁾	up to 225
Adjustable trip thresholds [A]	0.03-0.05-0.1-0.3 0.5-1-3-5-10	0.03-0.1-0.3 0.5-1-3	0.03-0.05-0.1-0.3 0.5-1-3-5-10	0.03-0.05-0.1-0.3 0.5-1-3-5-10	0.03-0.05-0.1 0.3-0.5-1
Selective type S	■	-	■	■	■
Adjustable NON-trip time settings [s] at 2xI _{Δn}	instantaneous 0.1-0.2-0.3- 0.5-1-2-3	instantaneous	instantaneous 0.1-0.2-0.3- 0.5-1-2-3	instantaneous 0.1-0.2-0.3- 0.5-1-2-3	instantaneous 0-0.1-0.2-0.3- 0.5-1-2-3
Power input	<10 W at 500V AC	<8 W at 500V AC	<10 W at 500V AC	<5 W at 500V AC	<10 W at 500V AC
Trip Coil with switch contact for trip signal	■	■	■	■	■
Input for remote controlled opening command	■	-	■	■	■
NO contact for pre-alarm signal	■	-	■	■	■
NO contact for alarm signal	■	-	■	■	■
Prealarm indication from 25% I _{Δn} . Steady yellow LED light	■	-	■	■	■
Alarm timing indication at 75% I _{Δn} . Flashing yellow LED light ⁽¹⁾	■	-	■	■	■
Type A for pulsating alternating current, Type AC for alternating current	■	■	■	■	■
Type B for pulsating current and direct current	-	-	-	-	■

⁽¹⁾ indication of alarm timing at 90% I_{Δn} for 30mA

⁽²⁾ plug-in and withdrawable version: the 160 frame can be used with a max I_n = 135A
the 250 frame can be used with a max I_n = 210A



Toroid

SACE RCQ020/A panel type residual current release (type A)

Tmax circuit breakers can also be used in conjunction with RCQ020 panel type residual current relays with separate toroid to be installed on the line conductors ("A" letter show the necessity to have on auxiliary power supply).

Thanks to its wide range of settings, the panel relay is suitable for:

- applications where the installation conditions are particularly restrictive, such as circuit breakers already installed or limited space in the circuit breaker compartment;
- creating a residual current protection system coordinated at various distribution levels, from the main switchboard to the end user;
- where residual current protection with low sensitivity is required, e.g. in partial (current) or total (time) selective chains;
- highly sensitive applications (physiological sensitivity) for protecting people against direct contacts.

Thanks to the 115-230...415V external auxiliary power supply, the RCQ020 panel-type residual current device is able to detect current leakage from 30mA to 30A and to act with a trip time that can be adjusted from instantaneous to delayed by 5s. The opening mechanism is the indirect action type and acts on the circuit breaker release mechanism by means of the shunt opening or undervoltage release of the circuit breaker itself.

The opening command to the circuit breaker (Trip delay) can be temporarily inhibited, and the circuit breaker can be opened by remote control by means of the RCQ020 device.

The following equipment must be requested when ordering:

- the RCQ020 device;
- an opening coil (SOR) or an undervoltage release (UVR) of the circuit breaker to be housed in the corresponding slot in the left pole of the circuit breaker itself;
- a closed toroid with a diameter from 60mm to 185mm that can be used for cables and busbars.

Signals available:

- LED to indicate the residual current device's status (supplied or not supplied). RCQ02 is equipped with a positive safety function that commands automatic circuit breaker opening in the absence of auxiliary voltage;
- LED for signaling faults;
- LED for signaling tripping of the residual current device;
- pre-alarm/alarm/trip electrical signals.



RCQ020/A residual current release

Power supply Voltage	AC: [V]	115-230...415
Operating frequency	[Hz]	45÷66Hz
Inrush current	@115V AC	500mA for 50ms
	@230V AC	150mA for 50ms
	@415V AC	100mA for 50ms
Power input at full rate		2 [VA] / 2 [W]
Trip threshold adjustment IΔn	[A]	0.03-0.05-0.1-0.3-0.5-1-3-5-10-30
No trip time adjustment	[s]	instantaneous 0.1-0.2-0.3-0.5-0.7-1-2-3-5
Pre-alarm threshold	x IΔn	25%
A type for pulsing alternate current		■

Signals

Device powered visual signaling	■
Visual signaling of device not functioning/ not configured	■
Visual signaling of residual current protection	■
Electrical alarm/pre-alarm signal	■
Electric trip signal	■

Controls

Remotely controlled opening command	■
Remotely controlled reset command	■

Operating range of closed transformers

Ø 60 [mm] toroidal transformer	[A]	In max = 250A Use 0.03..30A
Ø 110 [mm] toroidal transformer	[A]	In max = 400A Use 0.03..30A
Ø 185 [mm] toroidal transformer	[A]	In max = 800A Use 0.1..30A
Connection to toroidal transformer		By means of 4 shielded or twisted conductors. Maximum tolerated length: 15m
Dimensions W x H x D	[mm]	96 x 96 x 77
Drilling for assembly on door	[mm]	92 x 92
Standard		IEC 60947-2 annex M

Accessories

Accessories for electronic trip units

3

	Accessories for electronic trip units		
	Ekip Display	Ekip LED Meter	External neutral
Distribution protection			
Ekip LS/I	–	–	–
Ekip I	–	–	–
Ekip LSI	■	■	■
Ekip LSIG	■	■	■
Motor protection			
Ekip M-LIU	–	–	–
Energy measurement			
Ekip E-LSIG	■	■	■

Ekip Display

This unit can be installed on the front of the solid state trip unit to show current values, alarms and protection/communication parameter programming.

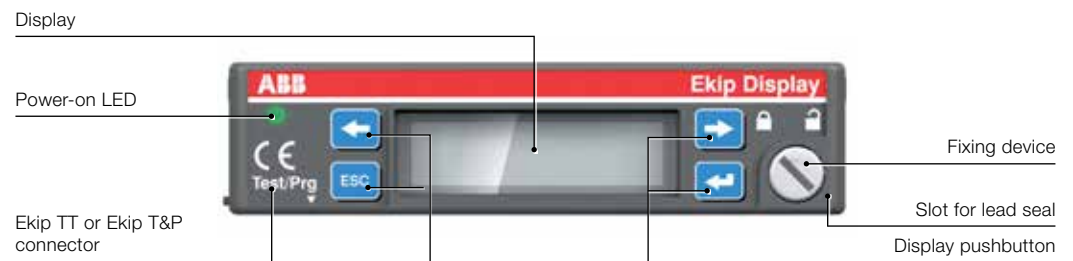

Main features:

- **installation:** Ekip Display can easily be installed on the front of the Ekip LSI, Ekip LSIG and Ekip E-LSIG electronic trip units. It is connected by means of the test connector on the front of the trip unit. Installation is simple and reliable thanks to a specially designed mechanism. It also provides a practical way of fastening the accessories to the circuit breaker in order to prevent undesired access to the dip-switches. Installation can be carried out under any conditions, even with the door closed and the electronic trip unit already on and functioning;
- **functions:** Ekip Display has four buttons for browsing through the menus. It functions in the self-supply mode starting from a current $I > 0.2 \times I_n$ circulating through at least one phase. Backlighting is activated in the presence of higher loads, making displayed information more legible. Backlighting comes on in self-supply for a current $I > 0.4 \times I_n$ and is always on when there is electronic trip unit auxiliary power supply.

Ekip Display:

- shows the current, voltage, power and energy values;
- shows the settings of the protection functions in Amperes or in I_n ;
- shows the protection that caused the release to trip and the fault current (only when there is 24V external voltage or the Ekip TT unit);
- allows the trip thresholds of the trip unit to be programmed and the communication parameters to be set on bus system;
- **compatibility:** Ekip Display can be fitted even when front accessories, such as the motor, direct and transmitted rotary handles etc. are already installed. It's possible to use Ekip TT or Ekip T&P without removing Ekip Display. It's not possible to use Ekip Display with the withdrawable version of circuit breaker.

Ekip LED Meter

The Ekip LED Meter can be applied to the front of the electronic trip unit. It displays the current values and alarms.

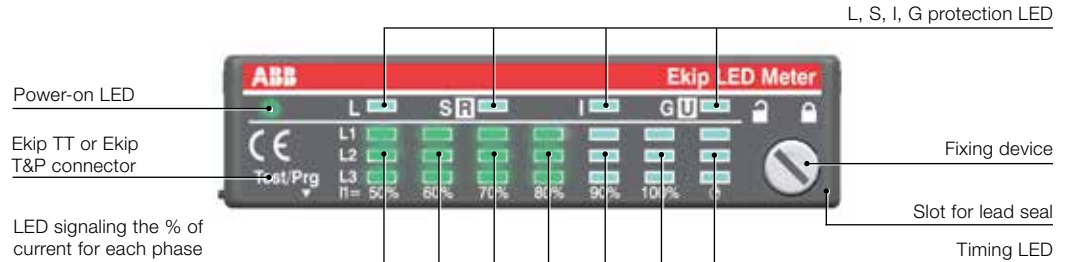

Main features:

- **installation:** Ekip LED Meter can be easily installed on the front of Ekip LSI, Ekip LSI G and Ekip E-LSIG electronic trip units. It is connected by means of the test connector on the front of the release. Installation is simple and reliable thanks to a specially designed mechanism. It also provides a practical way of fastening accessories to the circuit breaker in order to prevent undesired access to dip-switches. Installation can be carried out under any conditions, even with the door closed and the electronic trip unit already on and functioning;
- **functions:** Ekip LED Meter provides an accurate indication of the value of the current circulating in the trip unit. It does this by means of its. Its different colors allow the normal operation, prealarm and alarm states of the circuit breaker to be recognized at a glance. It functions in self-supply mode from a current of $I > 0.2 \times I_n$ circulating through at least one phase or when electronic trip unit's auxiliary power is available;
- **compatibility:** the Ekip LED Meter can also be fitted with front accessories, such as the motor, direct and transmitted rotary handles. Ekip TT or Ekip T&P can be used without removing Ekip LED Meter. Ekip LED Meter cannot be used when the breaker is in the withdrawable version.

Current sensor for external neutral

The current sensor for external neutral is applied to the uninterrupted neutral conductor. It allows neutral current for all protection functions to be read.

Main features:

- **installation:** the external neutral current sensor is available for XT2 and XT4 three-pole circuit breakers in the fixed/plug-in and withdrawable version equipped with an Ekip LSI or an Ekip LSI G electronic trip unit. The sensor must be connected to the release with the specific connector, which must be ordered separately.

Connection accessories

Devices that allow the electronic trip unit to be connected to external plant units or components. These connectors are available for the circuit breakers in fixed, plug-in and withdrawable versions.



Connector for 24V

Name of connector	Trip Units
External neutral connector	Ekip LSI – Ekip LSI G – Ekip E-LSIG
Connector for 24V DC auxiliary power supply	Ekip LSI – Ekip LSI G – Ekip E-LSIG

The connector for the auxiliary power supply is inserted inside the right-hand slot of the circuit breaker, and occupies the space of two due auxiliary contacts. To check compatibility with the auxiliary contacts, consult the compatibility tables in this chapter.

Accessories

Communication devices and systems

HMI030 interface on the front of the switchboard

HMI030 is an interface on the front of the switchboard and is usable with protection trip units fitted with Ekip Com.

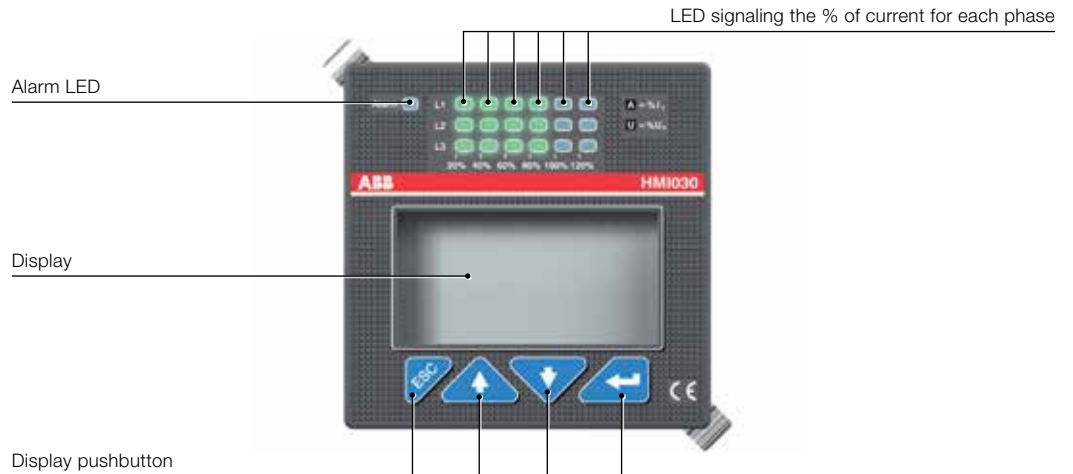

Main features:

- **installation:** HMI030 can be fitted into the hole in the door using the automatic click-in method. In situations where mechanical stress is particularly intense, it can also be installed by using the special clips supplied. It must be connected directly to the Ekip LSI, Ekip LSI^G or Ekip E-LSI^G protection trip unit with Ekip Com via the serial communication line. HMI030 requires a 24V DC power supply;

- **functions:** HMI030 consists of a graphic display and 4 buttons for browsing through the menus. This accessory allows you to view:
 - the measurements taken by the release to which it is connected;
 - the alarms/events of the release.

Thanks to its high level of accuracy, the same as that of the trip unit protection, the device is a valid substitute for conventional instruments without any additional current transformers.

- **communication:** HMI030 is provided with two communication lines. Either one can be used.

- Modbus
- Local Bus.

Connecting Ekip LSI, Ekip LSI^G or Ekip E-LSI^G to the Local Bus allows the Modbus line to be connected to a different communication network.

Consult the "Electrical diagrams" chapter for further details about wiring.

Ekip Com

Ekip Com allows the MOE-E motor operator to be controlled, determines the ON/OFF/TRIP state of the circuit breaker and connects the electronic trip unit to a Modbus communication line.

Ekip Com is available in two versions: one for fixed/plug-in circuit breakers and one, complete with connectors for both the fixed and moving parts, for withdrawable circuit breakers.

Main characteristics:

- installation:** the Ekip Com module is inserted into the special area in the right-hand pole of the circuit breaker and can be fastened without screws or tools. To connect with the trip unit, a special cable that is fitted with a cable guide is used to ensure an easy and safe installation. The Modbus line is connected by means of a terminal box, to which a 24V DC auxiliary power supply must be connected. The connection of the Modbus line is made by means of the terminal box to which a 24V DC auxiliary power supply must also be connected. The auxiliary power activates both the module and the protection trip unit;
- functions:** the Ekip Com module allows for remote reading of the circuit breaker's status. In combination with an MOE-E motor operator, it can open/close the circuit breaker remotely. Combined with a trip unit fitted with a communication device (Ekip LSI, Ekip LSIG or Ekip E-LSIG), the Ekip Com module allows the trip unit's connection to a Modbus network. This allows protections to be programmed, measurements to be taken and alarms to be sent when it's connected to a control and/or monitoring system. Connected to the HMI030 interface, these data can be displayed directly on the front of the switchboard.

For further details on the communication systems which can be made by means of the Ekip Com module, refer to the "Communication systems" section in the "Ranges" chapter.

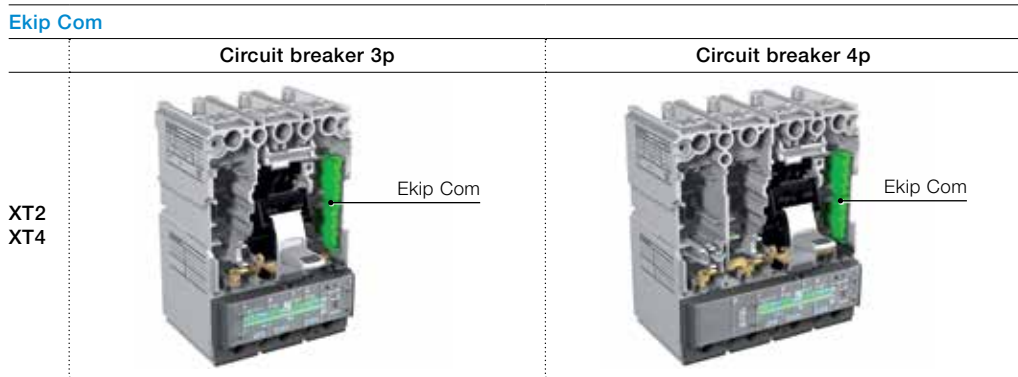

Accessories

Communication devices and systems

Ekip Connect

Installation and diagnosis software for ABB SACE products with Modbus RTU communication. The software can be used during the commissioning stage, or for troubleshooting in an up and running communication network.



Ekip Connect automatically scans the RS-485 bus, detects all the connected devices and checks their configuration, all possible addresses, parity and baud rate combinations. A simple click over SCAN will highlight:

- devices that fail to respond;
 - configuration errors;
 - incorrect addresses and parity;
 - any wiring errors (with the SACE electronic trip unit);
- achieving a complete diagnosis of the communication network.

This user-friendly software makes installing the Modbus communication network very easy.

Ekip Connect can be downloaded free of charge from the BOL (<http://bol.it.abb.com>) or ABB (www.abb.com) websites.

Accessories

Test and configuration accessories



Ekip T&P

Ekip T&P

Ekip T&P is a kit used to monitor, configure and test electronic protection trip units.

The kit includes:

- Ekip T&P unit;
- Ekip TT unit;
- Adapters for Emax and Tmax trip units;
- USB cable for connecting the Ekip T&P unit to the electronic trip unit;
- CD for installing Ekip Connect and the Ekip T&P driver.

The Ekip T&P unit is connected on one side to the USB port of a PC and on the other, by means of a cable provided, to the protection trip unit of the SACE Tmax XT series.

The Ekip T&P unit allows automatic, manual and trip tests of the device it is connected to.

These functions are managed by means of the Ekip T&P Interface which can only be activated directly by the Ekip Connect when the Ekip T&P is present and connected to the PC.



Ekip TT

Ekip TT

The Ekip TT accessory is supplied with a special connector to facilitate connection between the electronic trip unit and the Ekip TT unit. The kit also includes an adapter that allows the Ekip TT unit to be used with the current Tmax breakers.

Ekip TT is a device which allows:

- verification that the electronic trip unit's opening solenoid and the circuit breaker's trip mechanism (trip test) are functioning properly;
- testing the LEDs on the electronic trip unit it's connected to;
- supplying auxiliary power to show the most recent protection interruption in the event of an intervention by the electronic unit. Simply linking Ekip TT to the electronic trip unit (or to the Ekip display or Ekip LED Meter), illuminates the LED light on the most recently interrupted protection.

Its reduced dimension makes it pocket sized.

	Ekip T&P functions						Ekip TT functions		
	Trip Test	Protection function test	Parameter reading	Protection parameter programming	Communication parameter programming	Thermal memory enabling/disabling	Trip test	LED test	Latest trip detection
Distribution protection									
Ekip LS/I	■	■	■	-	-	■	■	■	■
Ekip I	■	■	■	-	-	-	■	■	■
Ekip LSI	■	■	■	■	■	■	■	■	■
Ekip LSIG	■	■	■	■	■	■	■	■	■
Ekip E-LSIG	■	■	■	■	■	-	■	■	■
Motor Protection									
Ekip M-LIU	■	■	■	-	-	-	■	■	■

Accessories

Automatic network-generator transfer unit ATS021-ATS022



ATS021



ATS022

The ATS (Automatic Transfer Switch) is the network-generator transfer unit used in installations where switching the main power line to an emergency one is required, in order to ensure power supply to the loads in the case of anomalies in the main line.

The unit is able to manage the entire transfer procedure automatically, and prepares the commands for carrying out the procedure manually as well.

In the case of an anomaly in the main line voltage, in accordance with the parameters set by the user, the opening of the circuit breaker of the main line, the starting of the generator set (when provided) and the closing of the emergency line are performed. In the same way, in the case of the main line returning, the procedure of reverse transfer is controlled automatically.

The new generation of ATS (ATS021 and ATS022) offers the most advanced and complete solutions to ensure service continuity. The ATS021 and ATS022 can both be used with all the circuit breakers in the SACE Tmax XT family and with the switch-disconnectors.

ATS021 and ATS022 devices have been designed to operate on self-supply. The ATS022 unit also prepares the connection for auxiliary power supply, allowing additional functions to be used.

ATS021 and ATS022 devices control both of the the power supply lines and analyze:

- phase unbalance;
- frequency unbalance;
- phase loss.

Apart from its standard control functions, the ATS022 unit makes it possible to:

- select the priority line;
- controlling a third circuit breaker;
- incorporate it into a monitoring system with Modbus communication (auxiliary power supply is needed);
- read/set parameters and show measurements and alarms on a graphic display.

Typical applications include: power supply to UPS (Uninterrupted Power Supply) units, operating rooms and primary hospital services, emergency power supply for civil buildings, airports, hotels, data banks and telecommunication systems, power supply of industrial lines for continuous processes.

For correct configuration, each circuit breaker connected to the ATS021 or ATS022 must be fitted with the following accessories:

- mechanical interlock;
- motorized control of opening and closing;
- key lock against purely manual operation for the motor operator;
- contact for signaling the status (open/closed) and contact for tripped;
- contact for racked-in (in the case of a withdrawable version circuit breaker).

Accessories

Test and configuration accessories

3

	ATS021	ATS022
General		
Auxiliary Power Supply	Not Required	Not Required (24-110V DC is required only for Modbus dialog and 16 2/3 Hz system)
Rated Voltage, Un [VAC]	Max 480	Max 480
Frequency [Hz]	50, 60	16 2/3, 50, 60, 400
Dimensions (HxLxD) [mm]	96x144x170	96x144x170
Type of installation	Door mounting DIN-rail mounting	Door mounting DIN-rail mounting
Operating Mode	Auto/Manual	Auto/Manual
Features		
Monitoring of the Normal and Emergency lines	■	■
Controlling CBs of the Normal and Emergency lines	■	■
Generator set startup	■	■
Generator set shutdown with adjustable delay	■	■
Bus-tie	-	■
No-priority Line	-	■
Modbus RS485	-	■
Display	-	■
Ambient conditions		
Operating temperature	-20...+60 °C	-20...+60 °C
Humidity	5% - 90% without condensation	5% - 90% without condensation
Align flush left thresholds		
Minimum voltage	-30%...-5%Un	-30%...-5%Un
Maximum voltage	+5%...+30%Un	+5%...+30%Un
Fixed frequency thresholds	-10%...+10%fn	-10%...+10%fn
Test		
Test Mode	■	■
Compliance with standards		
Electronic equipment for use in power installations	EN-IEC 50178	EN-IEC 50178
Electromagnetic compatibility	EN 50081-2	EN 50081-2
	EN 50082-2	EN 50082-2
Environmental conditions	IEC 68-2-1	IEC 68-2-1
	IEC 68-2-2	IEC 68-2-2
	IEC 68-2-3	IEC 68-2-3

Accessories

Compatibility of accessories

3



Three-pole circuit breaker



Four-pole circuit breaker

Check whether the different devices are compatible/incompatible with each other when ordering accessories. The following table provides a simple check between:

- mechanical accessories, accessories for electronic trip units and motors;
- internal electrical accessories.

To better understand the abbreviations used to identify the accessories, refer to the “Symbols” paragraph in chapter 8, “Glossary”.

Example of reading the compatibility tables

Fixed/plug-in circuit breaker compatibility XT1-XT3

	SOR 3p	UVR 3p	3Q 3p	SOR 4p	UVR 4p
SOR 3p				✓	✓	
UVR 3p ¹	↑ ²	↑ ³	↑ ⁴	↑ ⁵	↑ ⁶	↑
3Q sx 3p	→	→	→	→	→	→
SOR 4p	✓	✓	✓		✓	
UVR 4p	✓	✓	✓	✓		
.....						

The **UVR** positioned in the slot of the **3rd pole⁽¹⁾** is:

- incompatible with the SOR positioned in the 3rd pole⁽²⁾;
- incompatible with the UVR positioned in the 3rd pole⁽³⁾;
- incompatible with the 3Q contacts on the left in the 3rd pole⁽⁴⁾;
- compatible with the SOR positioned in the slot of the 4th pole⁽⁵⁾;
- compatible with the UVR positioned in the slot of the 4th pole⁽⁶⁾.
-

Compatibility of mechanical accessories

	RHD	RHE	RHS	FLD	PLL on CB	KLC on CB	KLC on RHX	KLC on FLD	MOD/MOE/MOE-E	Ekip Display	Ekip LED Meter	SOR/UVR/3 Form C/Q L 3p	1 Q + 1 SY	2 Q + 1 SY	3 Q + 1 SY
RHD							✓			✓	✓	✓	✓	✓	✓
RHE							✓			✓	✓	✓	✓	✓	✓
RHS										✓	✓	✓	✓	✓	✓
FLD								✓		✓	✓	✓	✓	✓	✓
PLL on CB										✓	✓	✓	✓	✓	✓
KLC on CB										✓	✓	✓	✓	✓	✓
KLC on RHX	✓	✓								✓	✓	✓	✓	✓	✓
KLC on FLD				✓						✓	✓	✓	✓	✓	✓
MOD/MOE/MOE-E										✓	✓	✓	✓	✓ ⁽¹⁾	✓ ⁽²⁾
Ekip Display	✓	✓	✓	✓	✓	✓	✓	✓	✓			✓	✓	✓	✓
Ekip LED Meter	✓	✓	✓	✓	✓	✓	✓	✓	✓			✓	✓	✓	✓
SOR/PS-SOR/UVR/3 Form C/Q L	✓	✓	✓	✓	✓	✓	✓	✓	✓	✓	✓	✓	✓	✓	✓
1 Q + 1 SY	✓	✓	✓	✓	✓	✓	✓	✓	✓	✓	✓	✓	✓	✓	✓
2/Q + 1 SY	✓	✓	✓	✓	✓	✓	✓	✓	✓ ⁽¹⁾	✓	✓	✓	✓	✓	✓
3 Q + 1 SY	✓	✓	✓	✓	✓	✓	✓	✓	✓ ⁽²⁾	✓	✓	✓	✓	✓	✓

✓ Compatibility ⁽¹⁾ Not valid for XT1 ⁽²⁾ Not valid for XT3

Compatibility of electrical accessories

Fixed/plug-in circuit breaker compatibility XT1-XT3

	SOR 3p	UVR 3p	SA 3p	3 Q L 3p	SA 3p	SOR 4p	UVR 4p	3 Q L 4p	1 Q + 1 SY	2 Q + 1 SY	3 Q + 1 SY	KLC on CB	MOD
SOR 3p						✓	✓	✓	✓	✓	✓		✓
UVR 3p						✓	✓	✓	✓	✓	✓		✓
3 Q L 3p						✓	✓	✓	✓	✓	✓		✓
SA 3p						✓	✓	✓	✓	✓	✓		✓
SOR 4p	✓	✓	✓	✓	✓				✓	✓	✓	✓	✓
UVR 4p	✓	✓	✓	✓	✓				✓	✓	✓	✓	✓
3 Q L 4p	✓	✓	✓	✓	✓				✓	✓	✓	✓	✓
1 Q + 1 SY	✓	✓	✓	✓	✓	✓	✓	✓				✓	✓
2 Q + 1 SY	✓	✓	✓	✓	✓	✓	✓	✓				✓	✓ ⁽¹⁾
3 Q + 1 SY	✓	✓	✓	✓	✓	✓	✓	✓				✓	
KLC on CB						✓	✓	✓	✓		✓		
MOD	✓	✓	✓	✓	✓	✓	✓	✓	✓	✓ ⁽¹⁾			

✓ Compatibility

⁽¹⁾ Not valid for XT1

3

Fixed/plug-in circuit breaker compatibility XT2-XT4

	SOR 3p	UVR 3p	3Q sx 3p	SA	AUE internal 3p	SOR 4p	UVR 4p	3Q sx 4p	S51	1Q 1SY	2Q 1SY	3Q SY	3Q 2SY	2Q 2SY 1S51	400V 2Q	400V 1Q 1SY	24V	Ekip Com	KLC on CB
SOR 3p					✓	✓	✓	✓	✓	✓	✓	✓	✓	✓	✓	✓	✓	✓	
UVR 3p					✓	✓	✓	✓	✓	✓	✓	✓	✓	✓	✓	✓	✓	✓	
3Q sx 3p						✓	✓	✓	✓	✓	✓	✓	✓	✓	✓	✓	✓	✓	
SA					✓	✓	✓	✓	✓	✓	✓	✓	✓	✓	✓	✓	✓	✓	
AUE internal 3p	✓	✓		✓		✓	✓	✓	✓	✓	✓	✓	✓	✓	✓	✓	✓	✓	
SOR 4p	✓	✓	✓	✓	✓				✓	✓	✓	✓	✓	✓	✓	✓	✓	✓	✓
UVR 4p	✓	✓	✓	✓	✓				✓	✓	✓	✓	✓	✓	✓	✓	✓	✓	✓
3Q sx 4p	✓	✓	✓	✓	✓				✓	✓	✓	✓	✓	✓	✓	✓	✓	✓	✓
S51	✓	✓	✓	✓	✓	✓	✓	✓		✓	✓						✓	✓	✓
1Q 1SY	✓	✓	✓	✓	✓	✓	✓	✓	✓								✓		✓
2Q 1SY	✓	✓	✓	✓	✓	✓	✓	✓	✓										✓
3Q 1SY	✓	✓	✓	✓	✓	✓	✓	✓											✓
3Q 2SY	✓	✓	✓	✓	✓	✓	✓	✓											✓
2Q 2SY 1S51	✓	✓	✓	✓	✓	✓	✓	✓											✓
400V 2Q	✓	✓	✓	✓	✓	✓	✓	✓											✓
400V 1Q 1SY	✓	✓	✓	✓	✓	✓	✓	✓											✓
24V	✓	✓	✓	✓	✓	✓	✓	✓	✓	✓									✓
Ekip Com	✓	✓	✓	✓	✓	✓	✓	✓	✓										✓
KLC on CB						✓	✓	✓	✓	✓	✓	✓	✓	✓	✓	✓	✓	✓	✓

✓ Compatibility

Accessories

Compatibility of accessories

Withdrawable circuit breaker compatibility XT2-XT4

	S51	1Q 1SY	3Q 1SY	3Q 2SY	2Q 2SY S51	400V 2Q	400V 1Q 1SY	Ekip Com	24V	NE	MOE	MOE-E	AUX- MOE	AUE	SOR 3p	UVR 3p	SA	SOR 4p	UVR 4p
S51		✓						✓	✓	✓	✓	✓	✓	✓	✓	✓	✓	✓	✓
1Q 1SY	✓								✓	✓	✓	✓	✓	✓	✓	✓	✓	✓	✓
3Q 1SY										✓	✓	✓	✓	✓	✓	✓	✓	✓	✓
3Q 2SY											✓	✓	✓	✓	✓	✓	✓	✓	✓
2Q 2SY S51											✓	✓	✓	✓	✓	✓	✓	✓	✓
400V 2Q										✓	✓	✓	✓	✓	✓	✓	✓	✓	✓
400V 1Q 1SY										✓	✓	✓	✓	✓	✓	✓	✓	✓	✓
Ekip Com	✓									✓	✓	✓	✓	✓	✓	✓	✓	✓	✓
24V	✓	✓									✓	✓	✓	✓	✓	✓	✓	✓	✓
NE	✓	✓	✓			✓	✓	✓			✓	✓	✓	✓	✓	✓	✓	✓	✓
MOE	✓	✓	✓	✓	✓	✓	✓	✓	✓	✓			✓ ⁽¹⁾	✓	✓	✓	✓	✓	✓
MOE-E	✓	✓	✓	✓	✓	✓	✓	✓	✓	✓			✓ ⁽¹⁾	✓	✓	✓	✓	✓	✓
AUX-MOE	✓	✓	✓	✓	✓	✓	✓	✓	✓	✓	✓ ⁽¹⁾	✓ ⁽¹⁾			✓	✓	✓	✓	✓
AUE	✓	✓	✓	✓	✓	✓	✓	✓	✓	✓	✓	✓			✓	✓	✓	✓	✓
SOR 3p	✓	✓	✓	✓	✓	✓	✓	✓	✓	✓	✓	✓	✓	✓				✓	✓
UVR 3p	✓	✓	✓	✓	✓	✓	✓	✓	✓	✓	✓	✓	✓	✓				✓	✓
SA	✓	✓	✓	✓	✓	✓	✓	✓	✓	✓	✓	✓	✓	✓				✓	✓
SOR 4p	✓	✓	✓	✓	✓	✓	✓	✓	✓	✓	✓	✓	✓	✓	✓	✓	✓		✓
UVR 4p	✓	✓	✓	✓	✓	✓	✓	✓	✓	✓	✓	✓	✓	✓	✓	✓	✓		✓

✓ Compatibility

⁽¹⁾ AUX-MOE always supplied with MOE and MOE-E

Characteristic curves and technical information

Characteristic curves

Examples of curve reading	4/2
---------------------------	-----

Trip curves with thermomagnetic trip unit

Trip curves for distribution	4/4
Trip curves for motor protection	4/10

Trip curves with electronic trip unit

Trip curves for distribution	4/11
Trip curves for motor protection	4/15

Specific let-through energy curves

480V	4/16
600V	4/18

Limiting curves

480V	4/20
600V	4/22

Technical information

Temperature performances	4/24
Dissipated powers	4/28

Example of curve reading

Example 1 – XT3N 225

Trip curves for distribution (thermomagnetic trip unit)

Let us consider an XT3N TMF $I_n = 225A$ circuit-breaker. According to the conditions the overload is found in; i.e., with the circuit-breaker at thermal regime or not, thermal protection tripping varies considerably.

For example, for an overload current $3xI_1$, the trip time is between 152,7s and 40,2s for cold tripping and between 40,2s and 6,9s for hot tripping.

For fault current values higher than 225A. The circuit-breaker trips with the instantaneous magnetic protection I3.

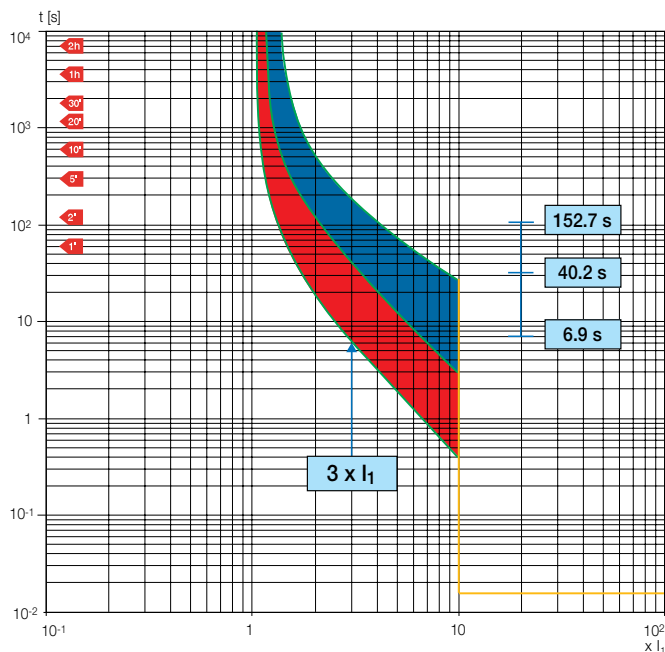

4

Example 2 – XT2H 125

Specific let-through energy curves

This figure shows a sample graph of the specific let-through energy of the XT2H 125 circuit-breaker at a voltage of 220/230V.

The prospective symmetrical short-circuit current is indicated on the abscissas, whereas the values of the specific let-through energy expressed in A^2s are shown on the ordinates. The circuit-breaker lets through a value of I^2t equal to $0,42 \cdot 10^6 \cdot A^2s$ relative to a short-circuit current of 14kA.

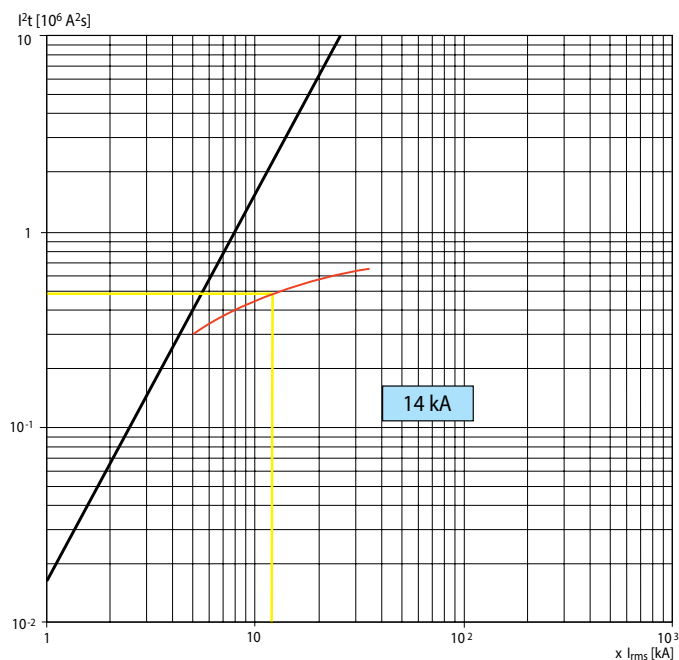

Example 3 – XT2L 125

Limitation curves

The figure at right gives the trend of the Limitation curves of the XT2L 125 $I_n = 125A$ circuit-breaker.

The effective value of the prospective symmetrical short-circuit current is given on the abscissas of the diagram, whereas the peak value corresponding to the prospective short-circuit current is indicated on the ordinates.

For a value current of 22kA, the XT2L 125 circuit breaker with a thermomagnetic trip unit $I_n = 125A$ limits the peak prospective short-current current to 18kA at a voltage of 600V.

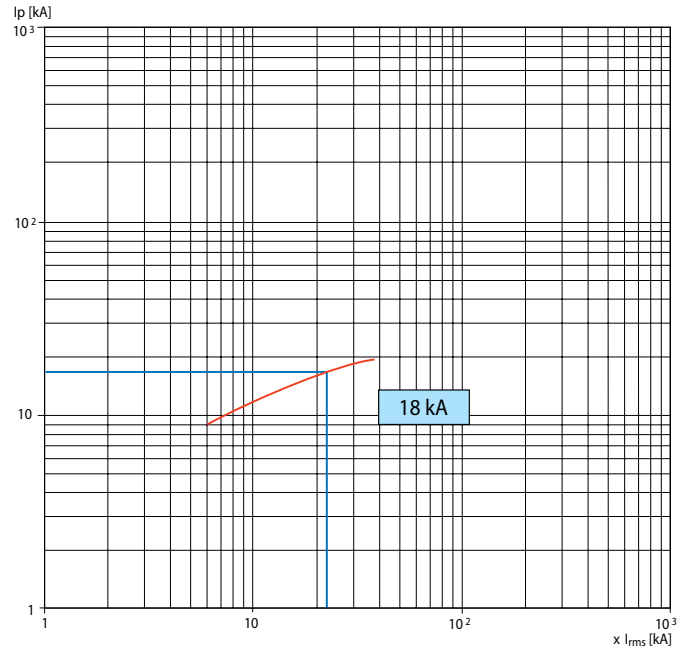

Trip curves with thermomagnetic trip unit

Trip curves for distribution

XT1 125 TMF In=15..30A

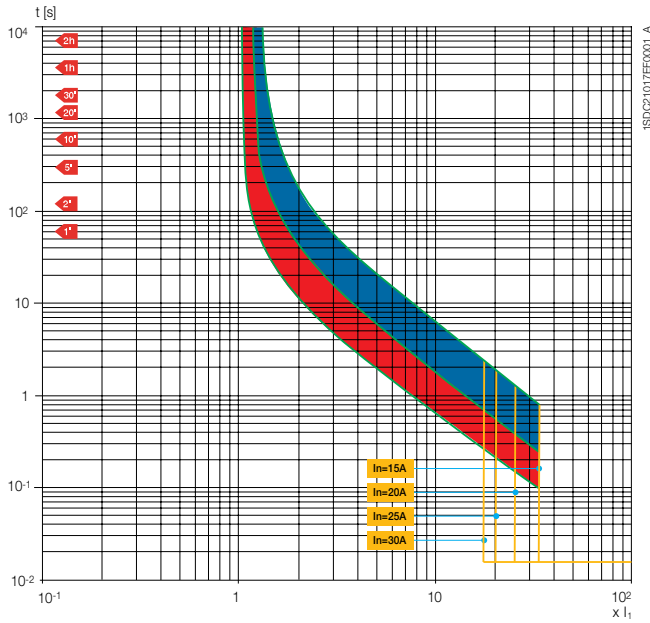

XT1 125 TMF In=35...50A

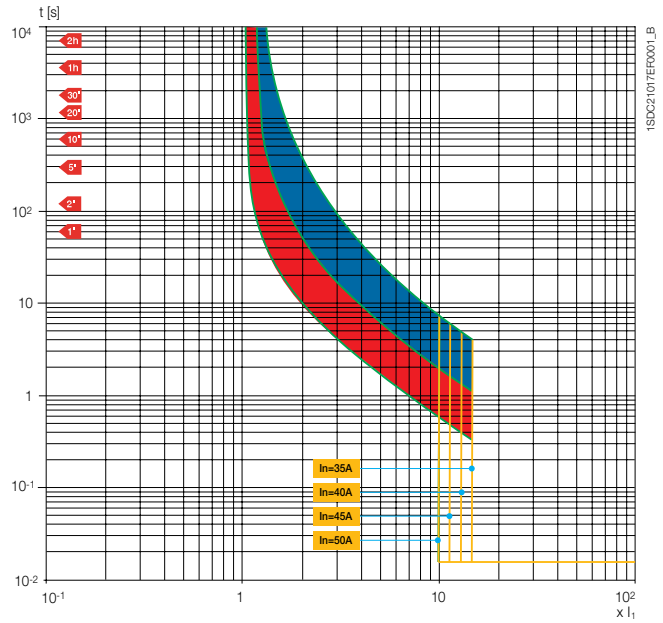

XT1 125 TMF In=60...100A

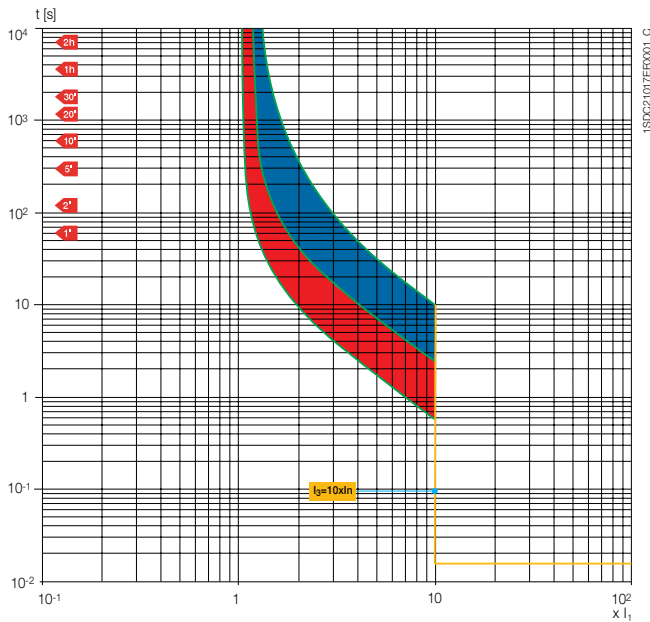

XT1 125 TMF In=125A

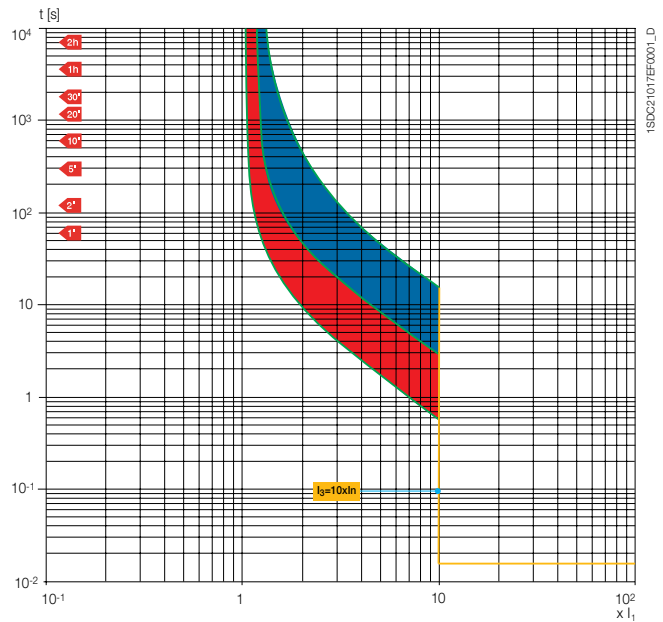

XT2 125 TMF In=15...30A

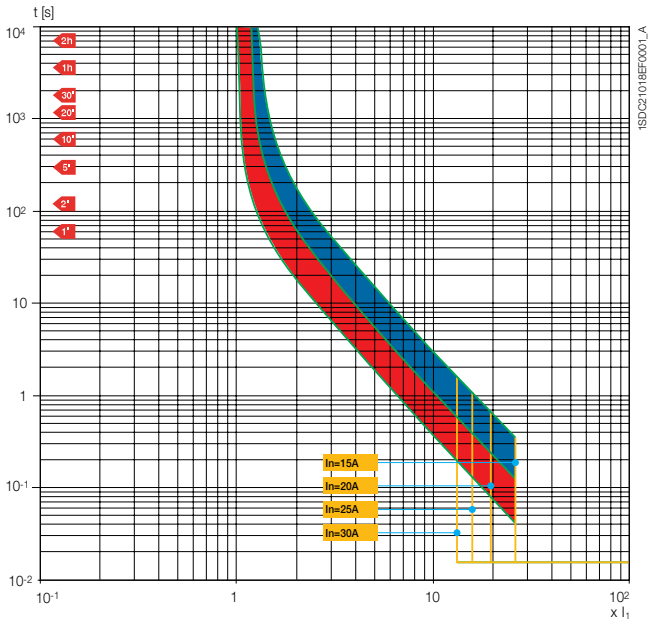

XT2 125 TMF In=35...50A

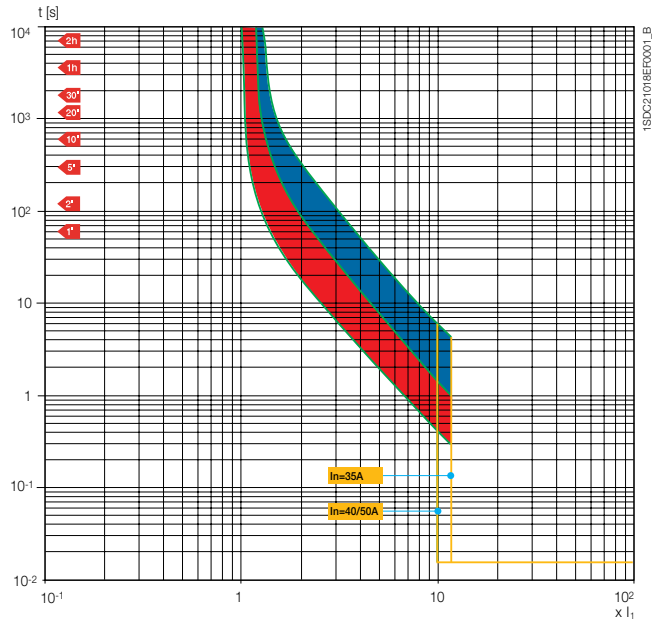

XT2 125 TMF In=60...70A

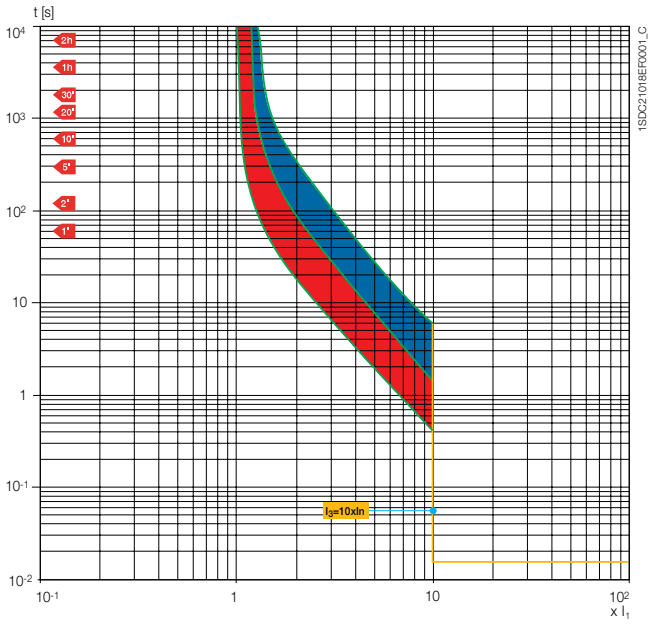

XT2 125 TMA In=80...100A

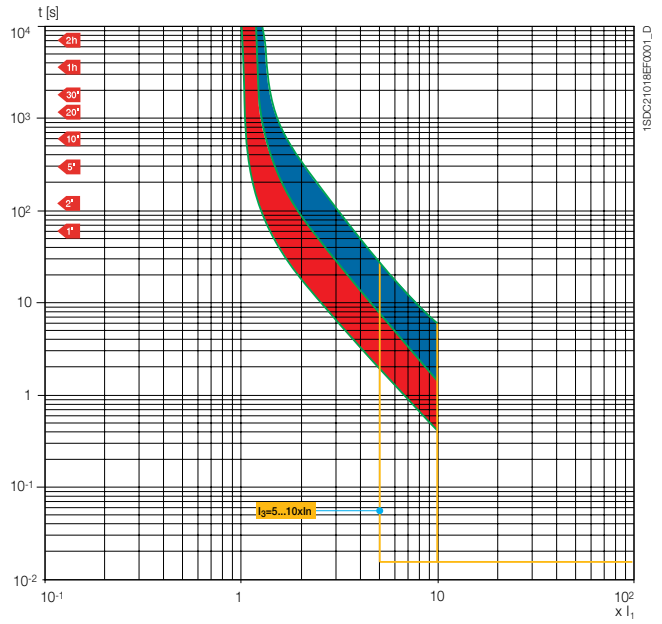

Trip curves with thermomagnetic trip unit

Trip curves for distribution

4

XT2 125 TMA In=110...125A

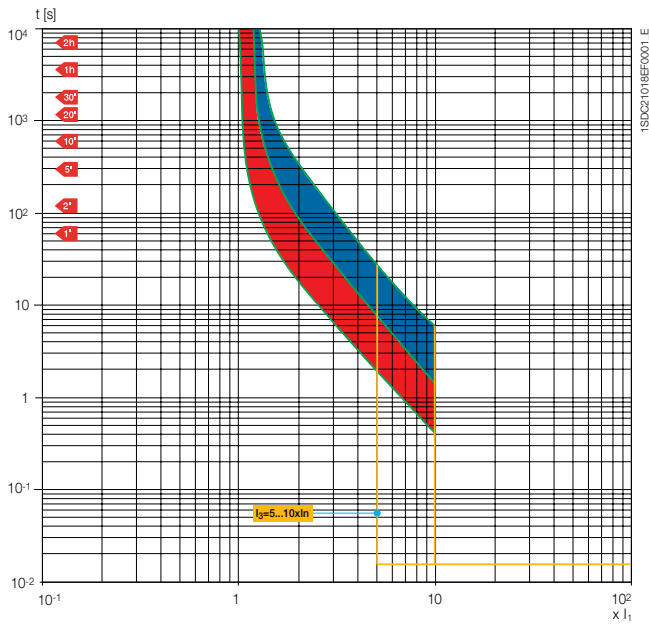

XT3 225 TMF In=60..100A

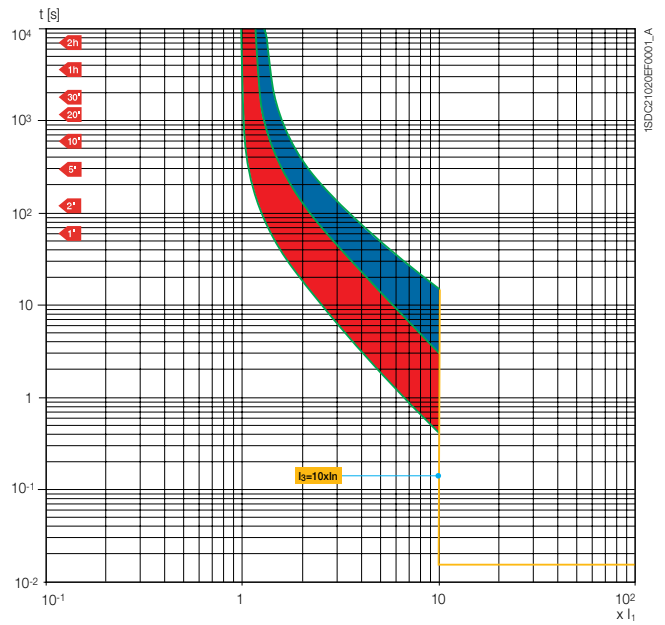

XT3 250 TMF In=110..150A

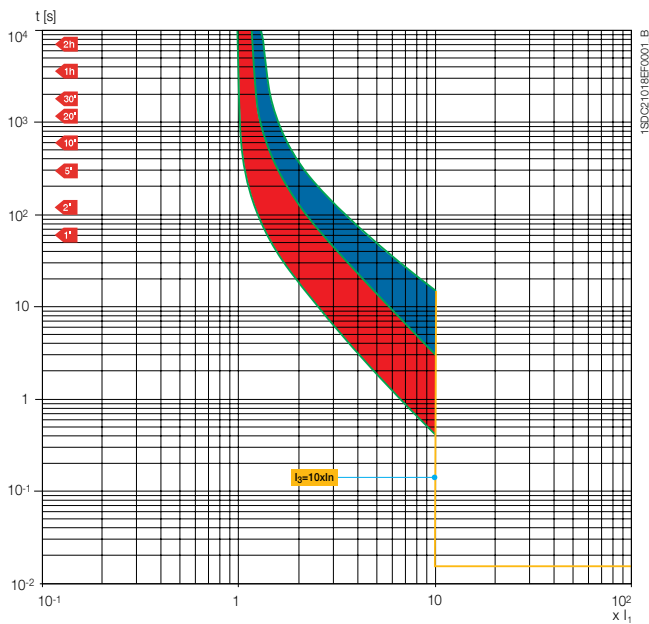

XT3 250 TMF In=160..225A

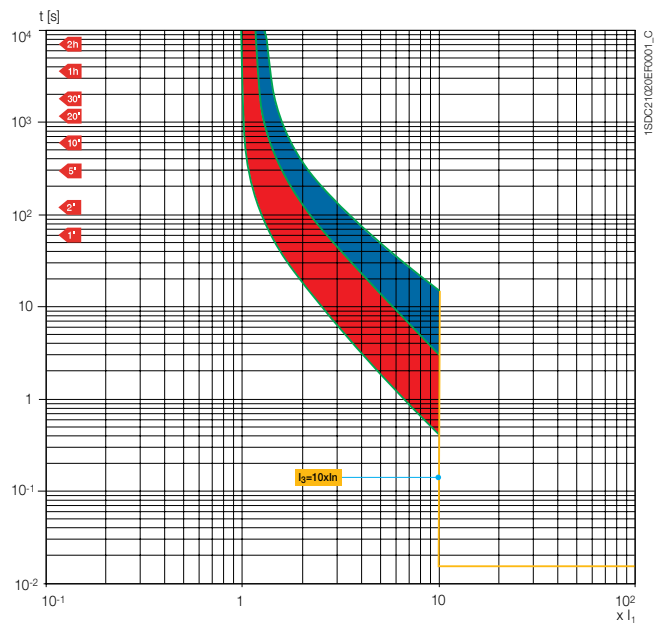

XT4 250 TMF In=25...50A

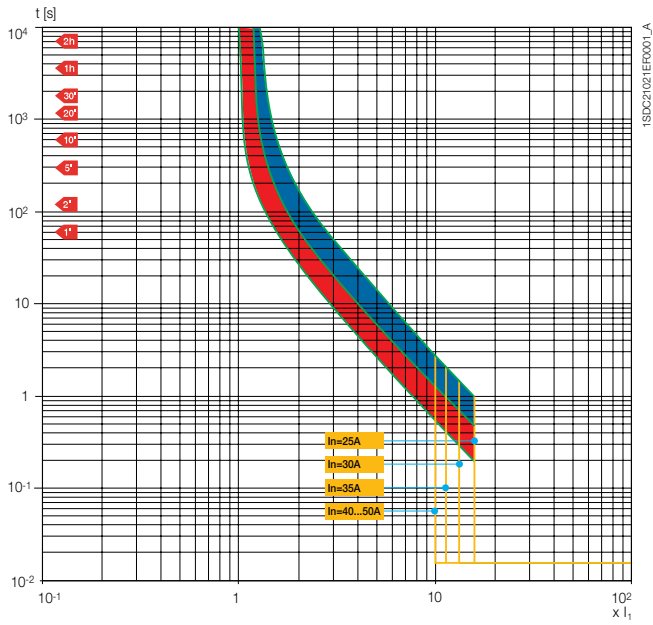

XT4 250 TMF In=60...70A

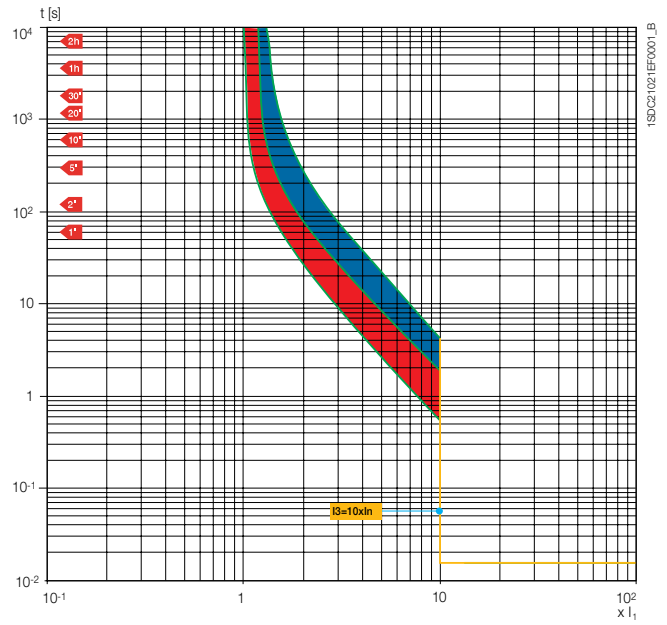

XT4 250 TMF In=80...100A

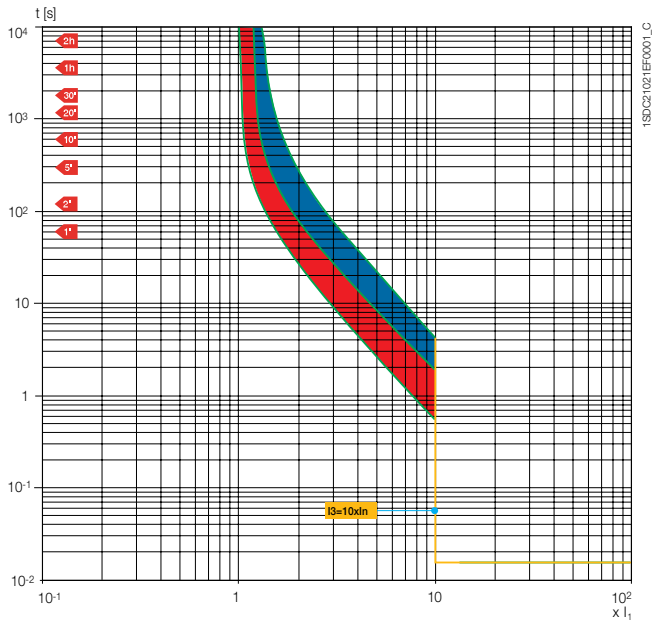

XT4 250 TMF In=110...150A

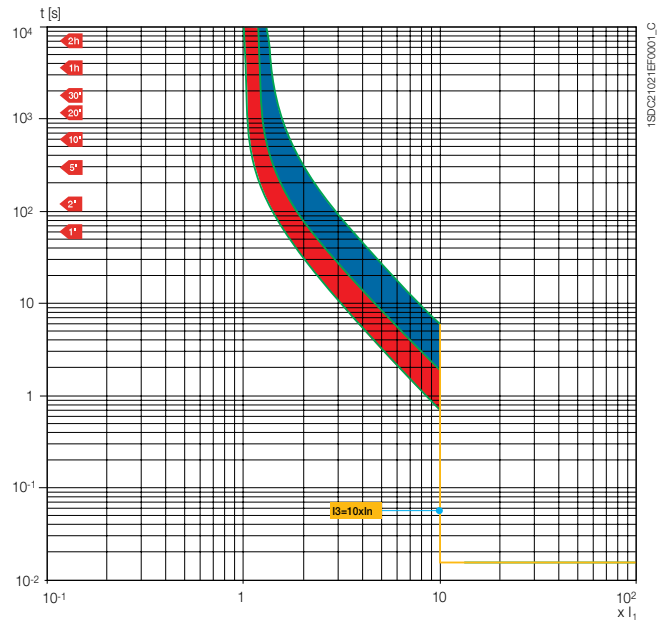

Trip curves with thermomagnetic trip unit

Trip curves for distribution

4

XT4 250 TMF In=160...225A

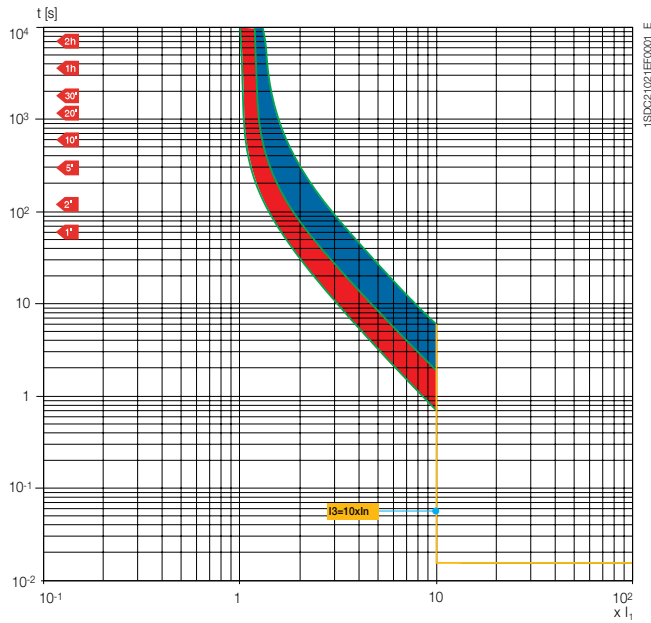

XT4 250 TMF In=250A

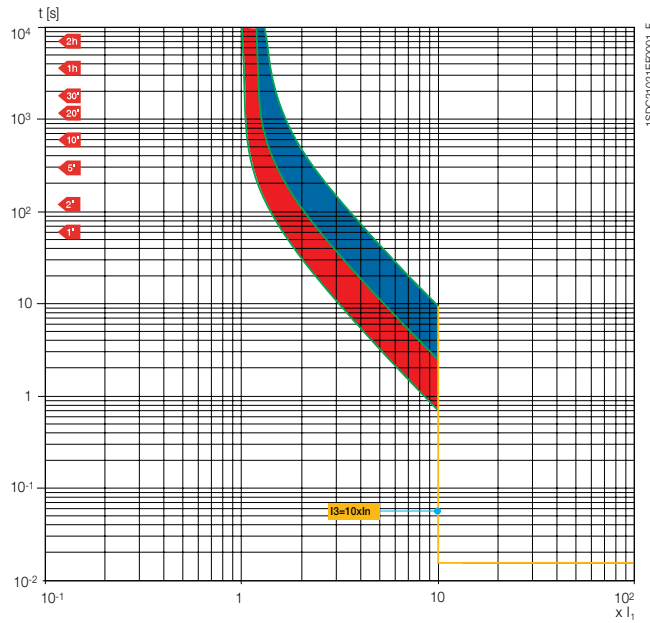

XT4 250 TMA In=80...100A

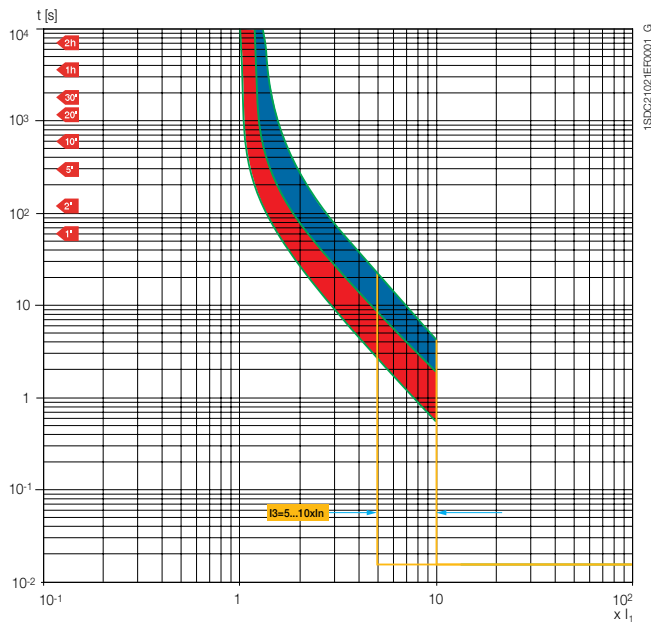

XT4 250 TMA In=110...150A

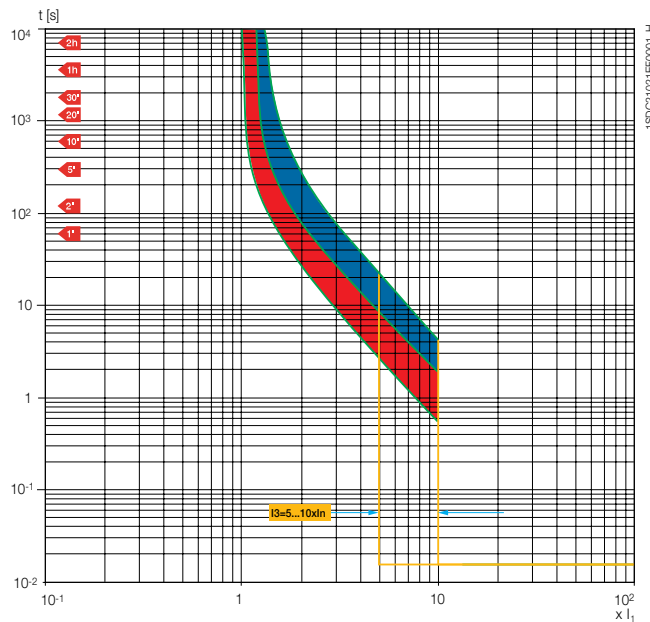

XT4 250 TMA In=160...225A

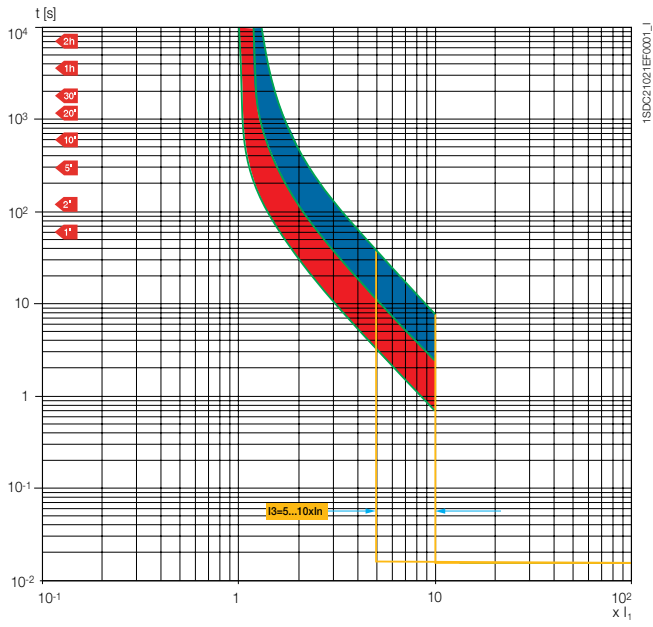

XT4 250 TMA In=250A

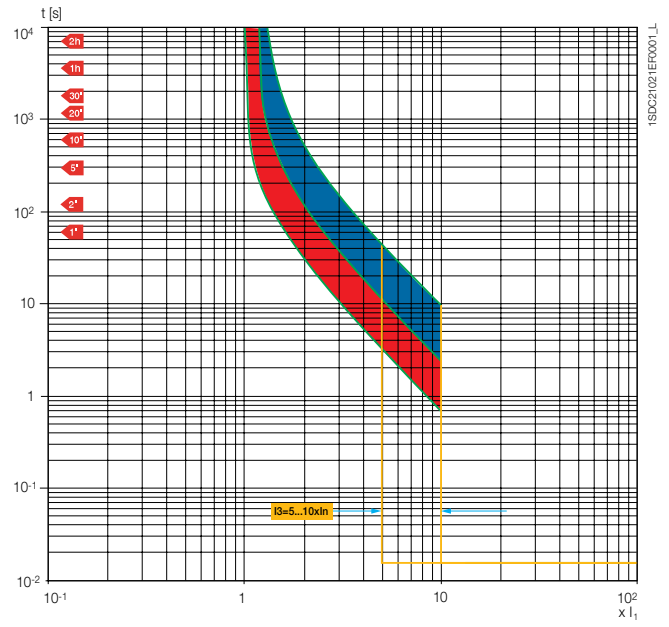

Trip curves with thermomagnetic trip unit

Trip curves for motor protection

XT1 125 MA $I_n=3...125A$

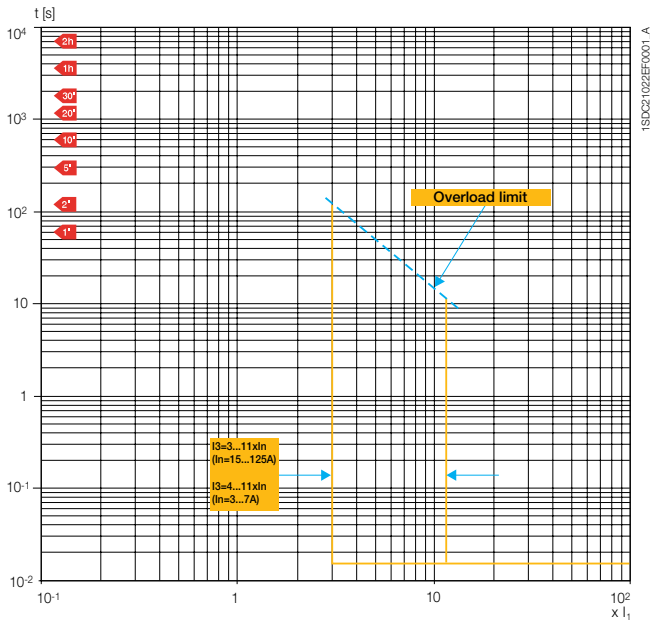

XT2 125 MA $I_n=125A$

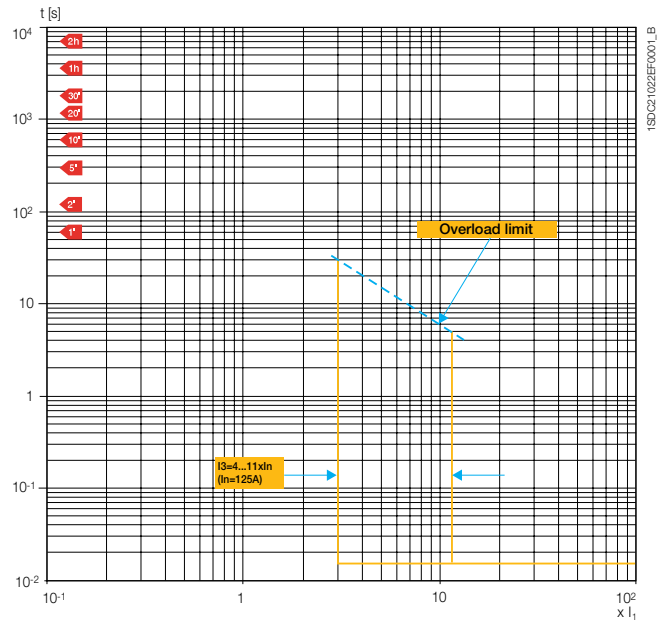

XT3 225 MA $I_n=100...200A$

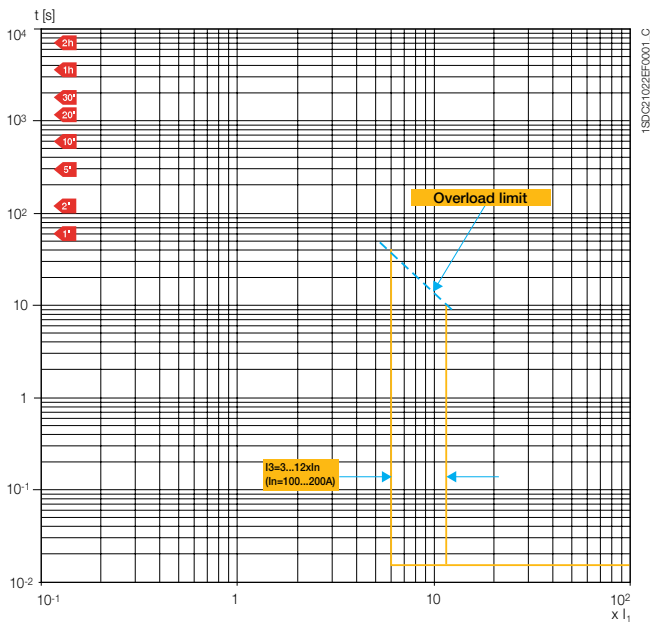

XT4 250 MA $I_n=80...250A$

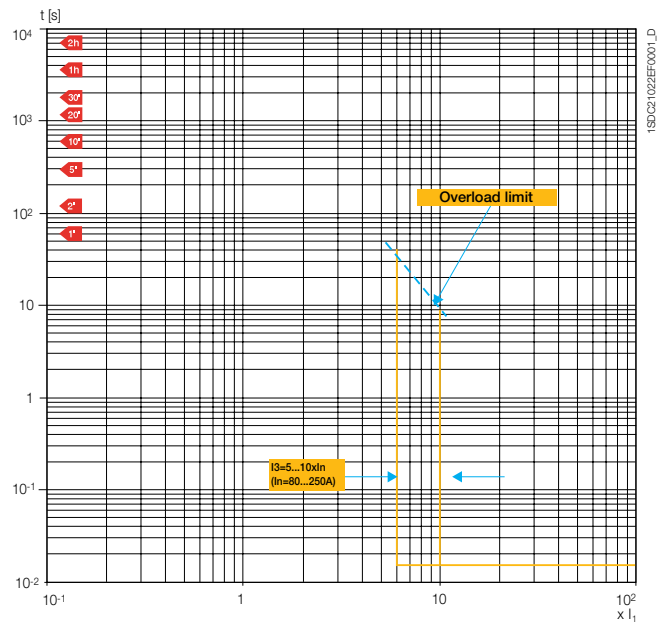

Trip curves with electronic trip unit

Trip curves for distribution

XT2 Ekip LS/I
L-I functions

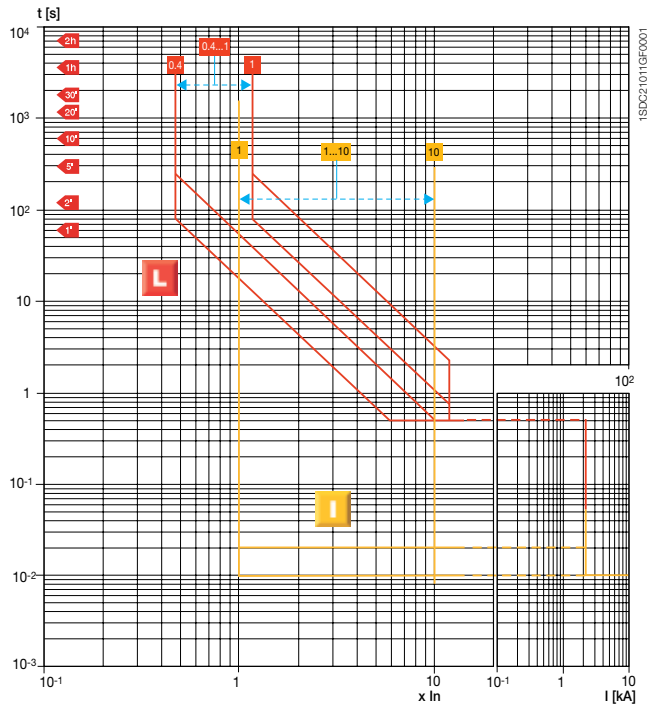

XT2 Ekip LS/I
L-S functions

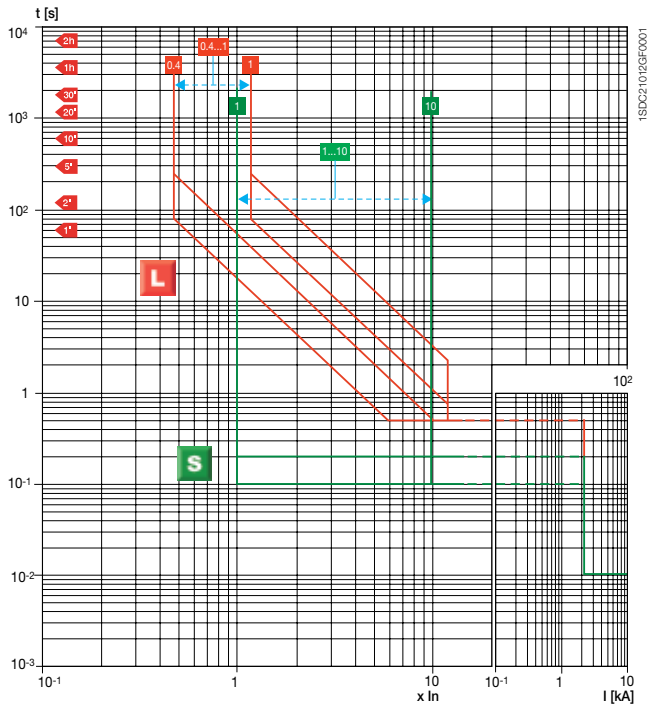

XT2 Ekip I
I function

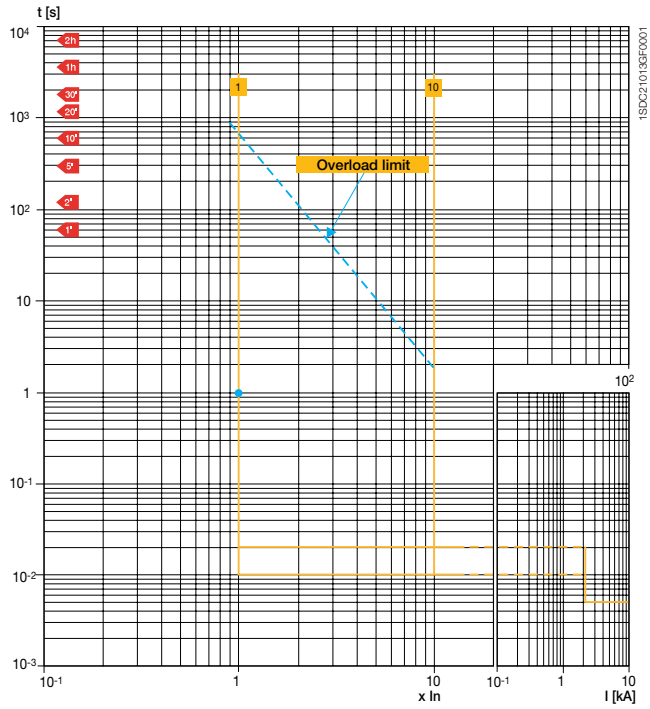

XT2 Ekip LSI
L-S-I functions

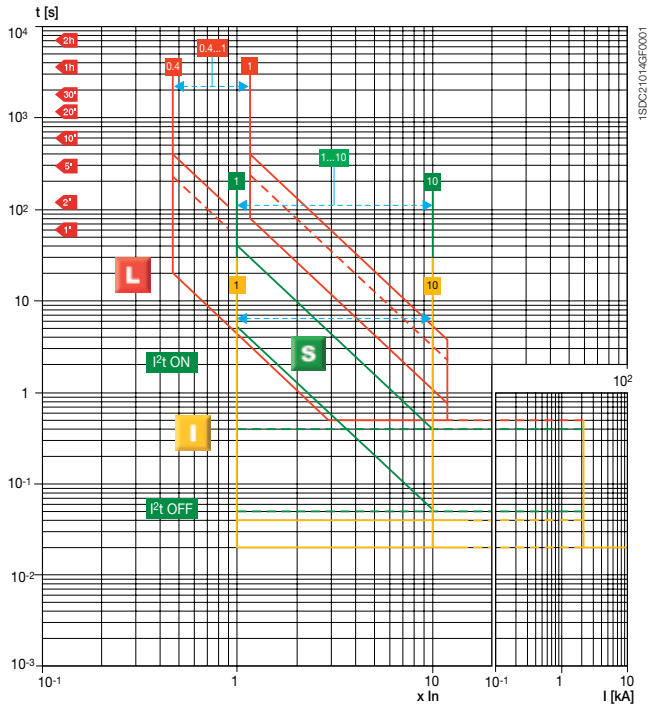

Trip curves with electronic trip unit

Trip curves for distribution

XT2 Ekip LSIG
L-S-I functions

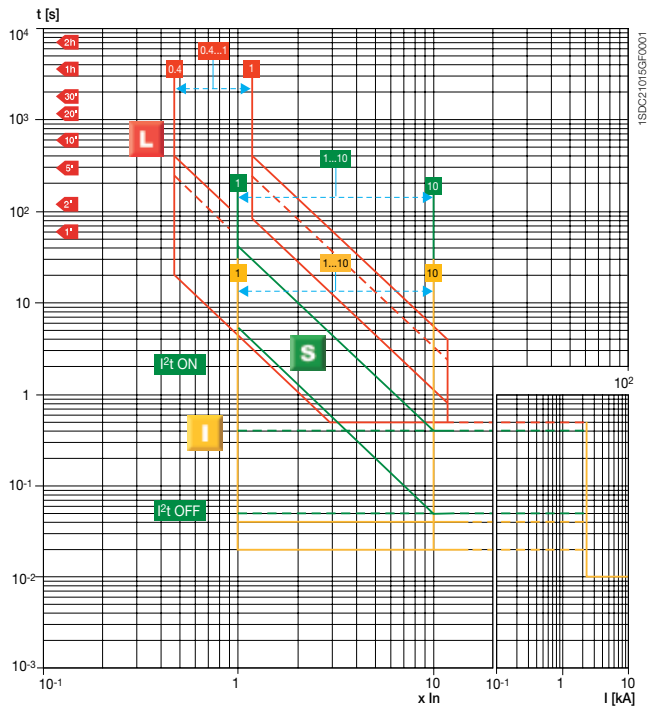

XT2 Ekip LSIG
G function

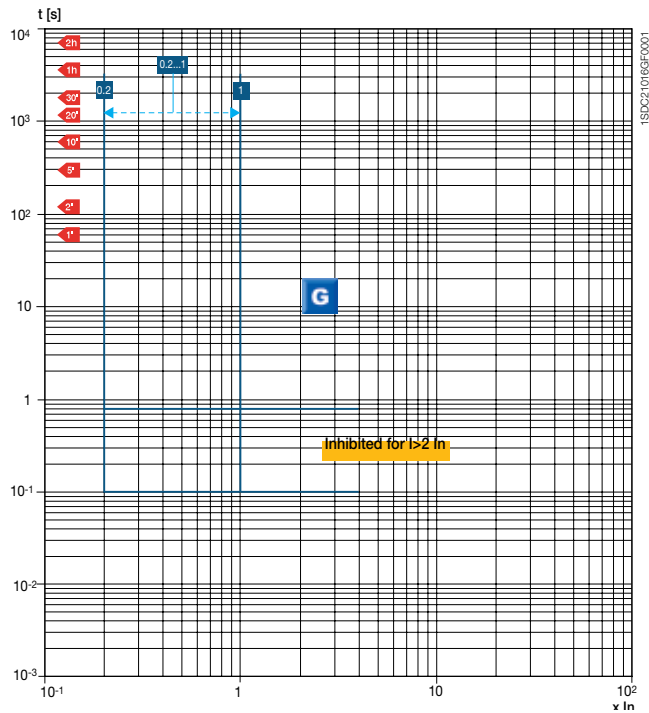

XT4 Ekip LS/I
L-I functions

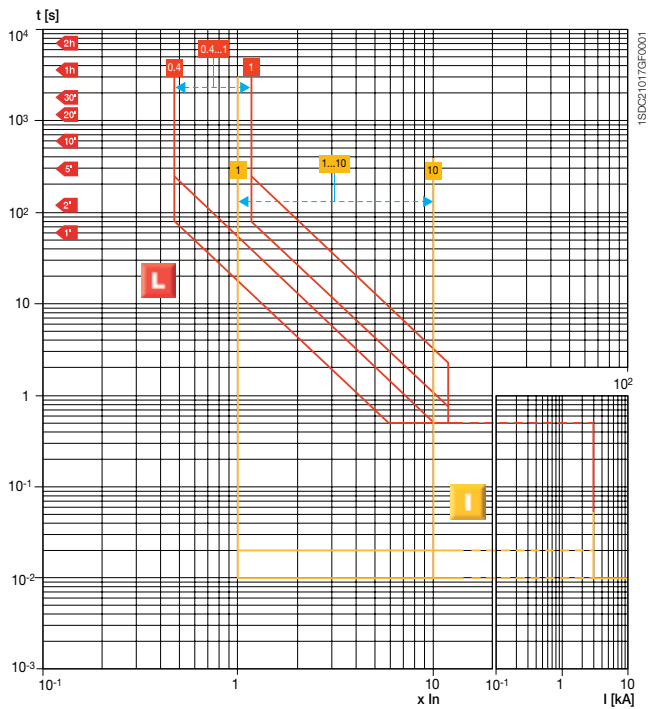

XT4 Ekip LS/I L-S
functions

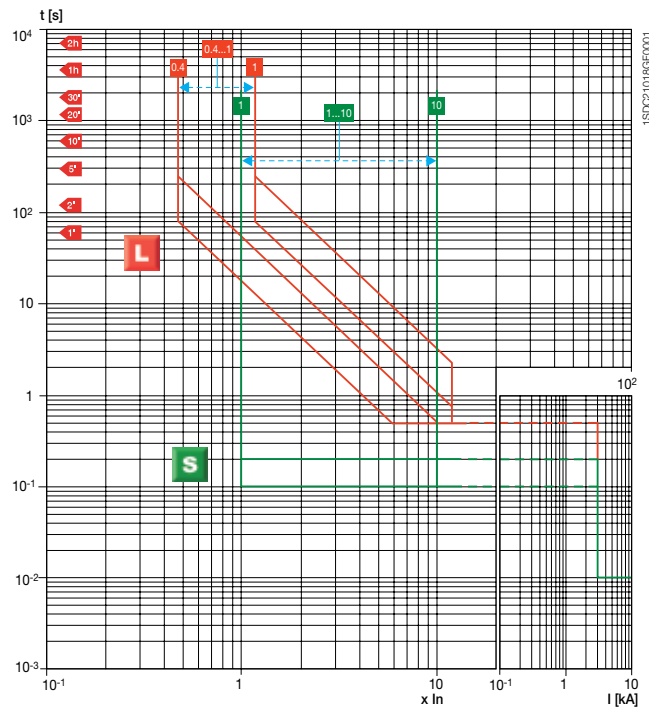

XT4 Ekip I
I function

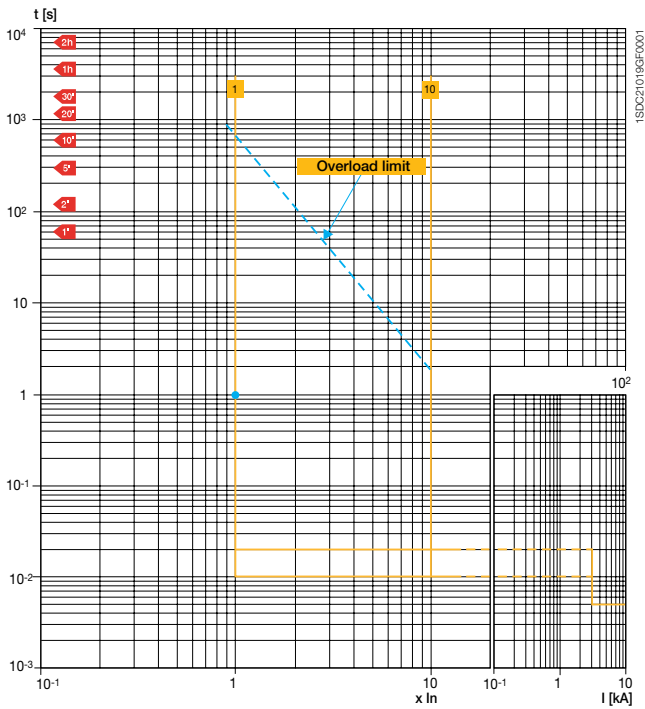

XT4 Ekip LSI
L-S-I functions

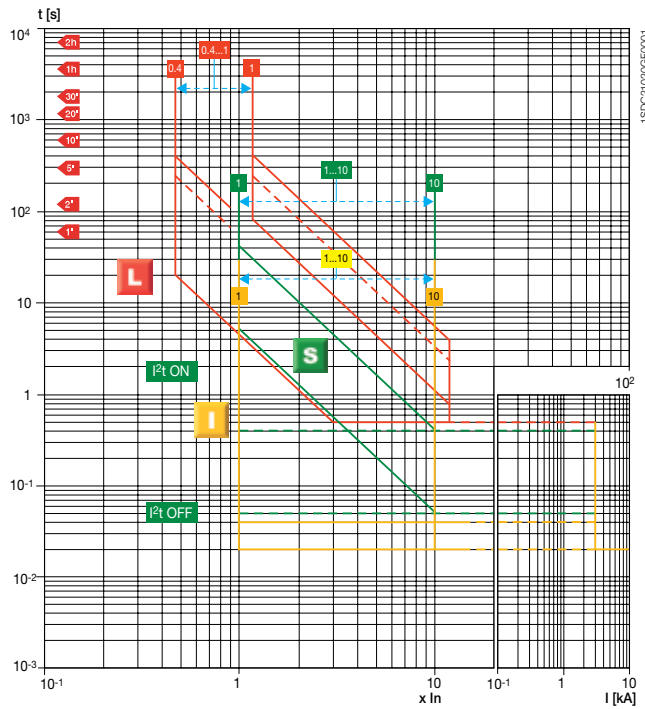

XT4 Ekip LSiG, Ekip E-LSiG
L-S-I functions

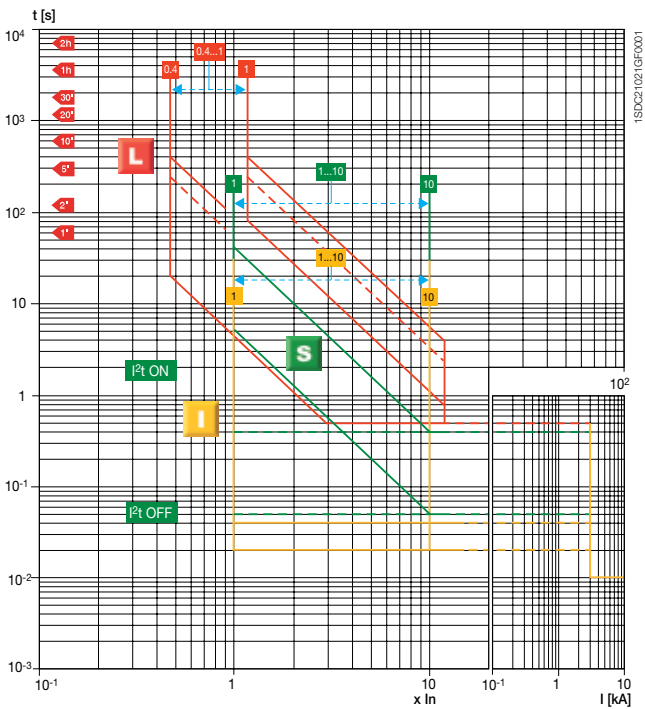

XT4 Ekip LSiG, Ekip E-LSiG
G function

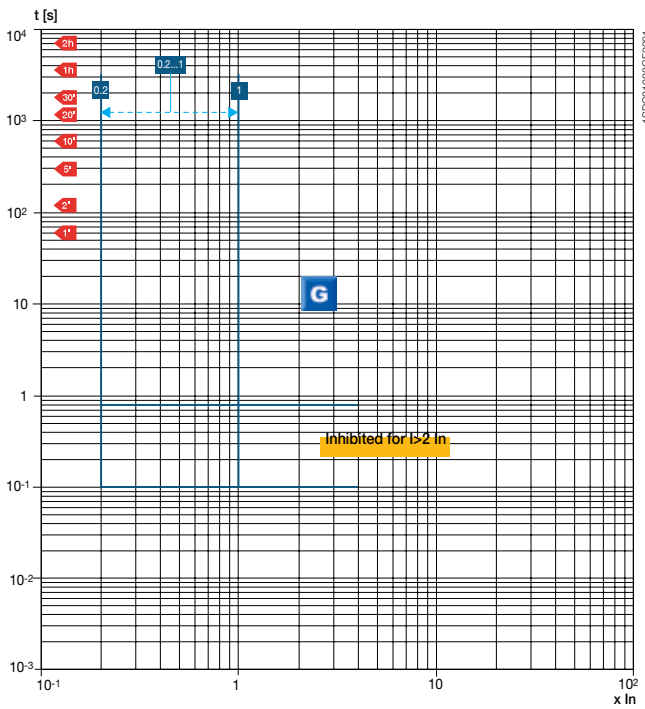

Trip curves with electronic trip unit

Trip curves for distribution

XT4 Ekip E-LSIG
OV protection

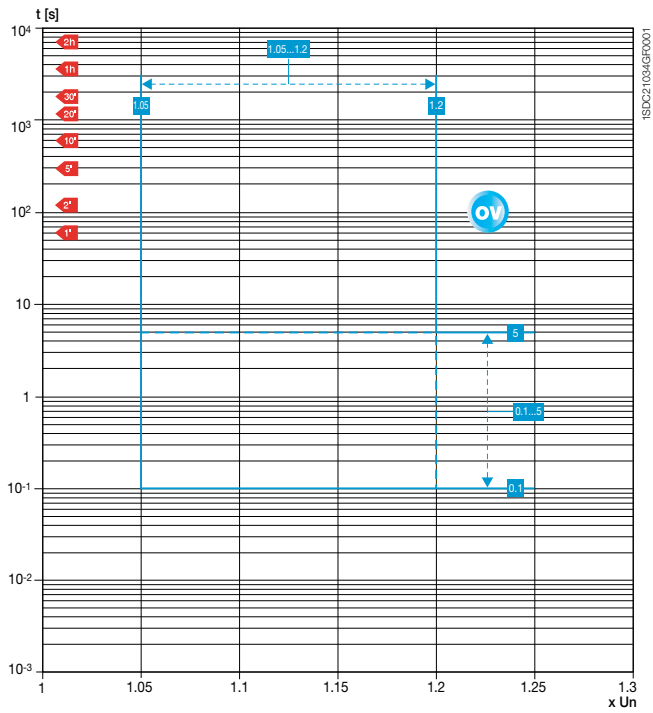

XT4 Ekip E-LSIG
UV protection

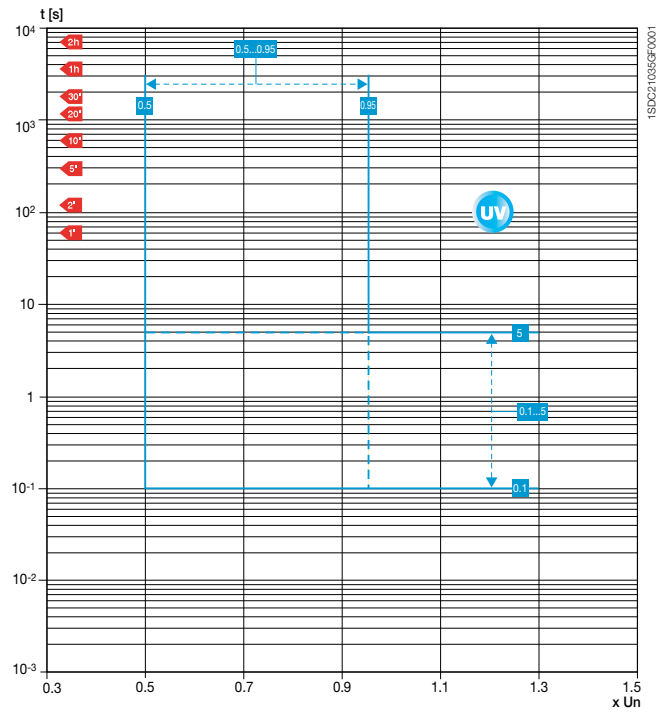

Trip curves with electronic trip unit

Trip curves for motor protection

XT2-XT4 Ekip M-LIU
L function (cold trip)

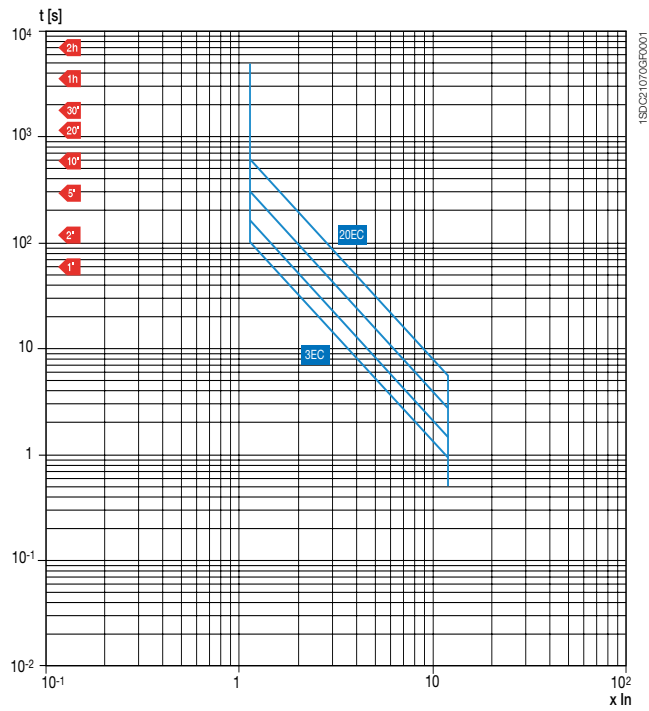

XT2-XT4 Ekip M-LIU
(hot trip)

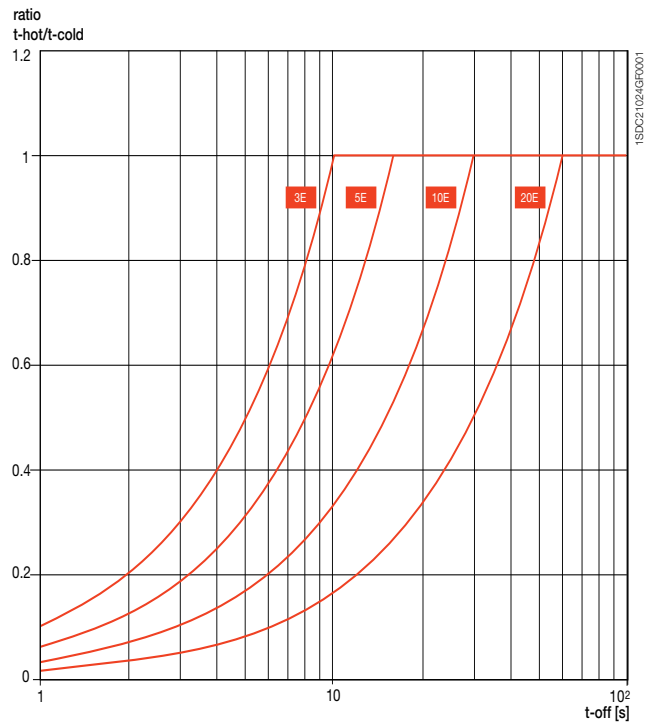

XT2-XT4 Ekip M-LIU
I function

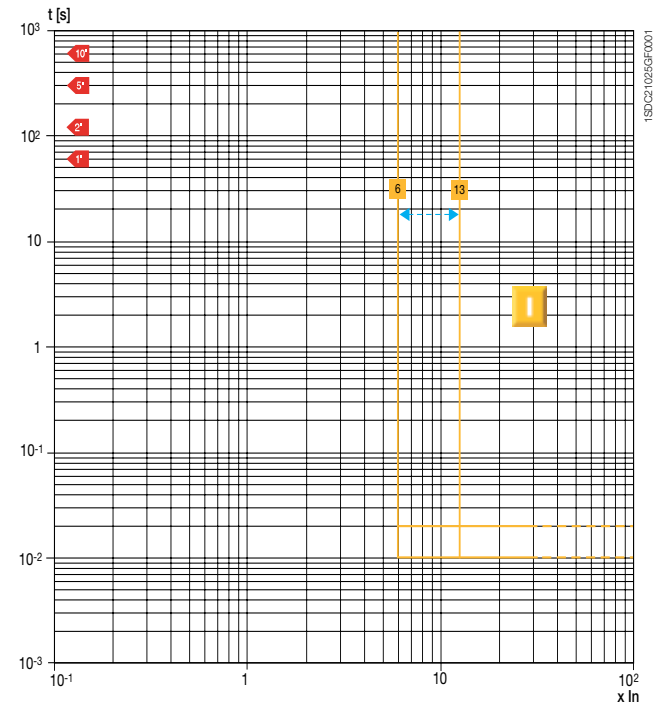

XT2-XT4 Ekip M-LIU
U function

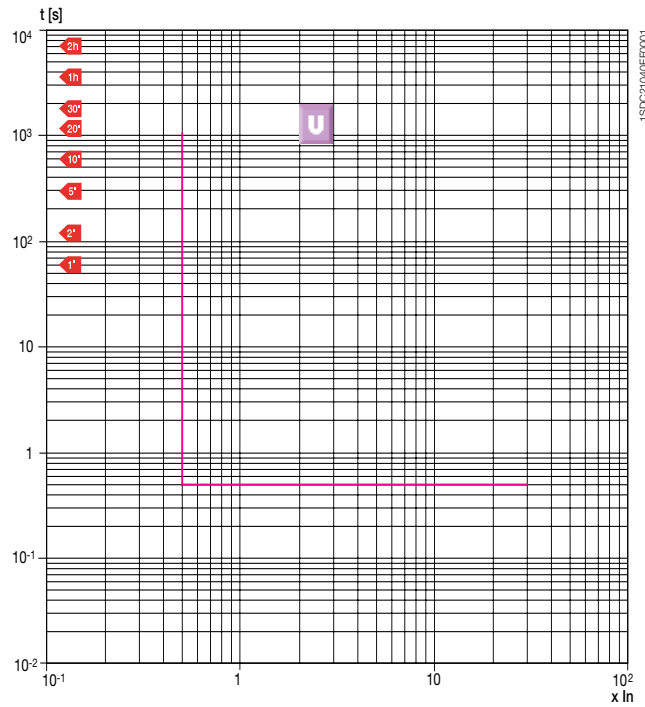

Specific let-through energy curves 480V

XT2H

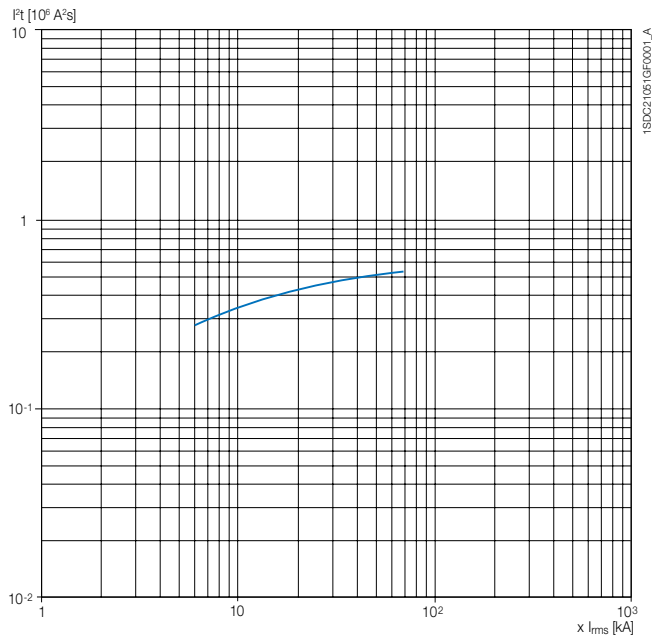

XT2L

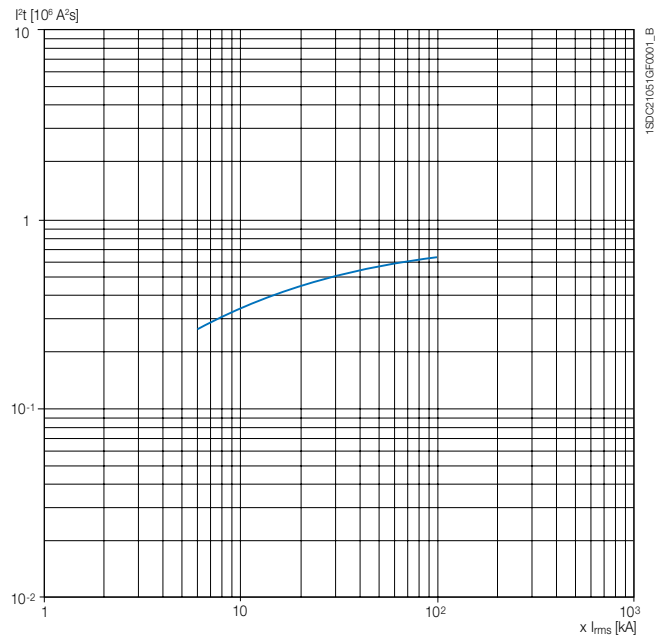

XT2V

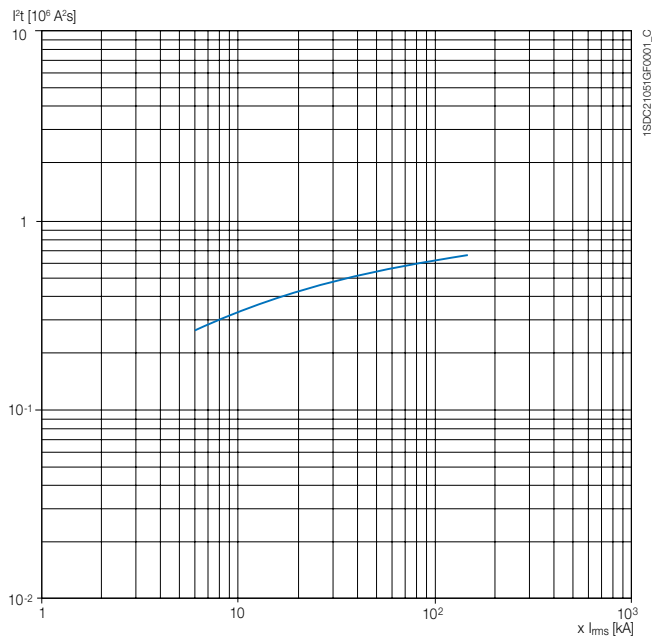

XT4H

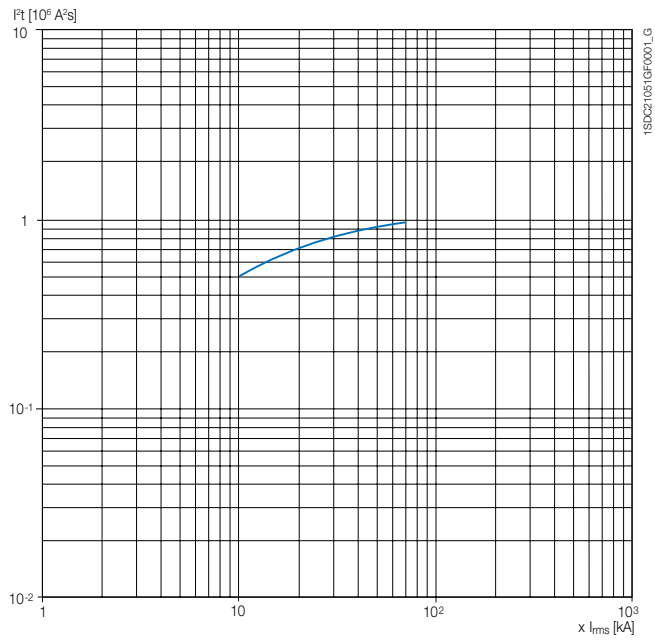

XT4L

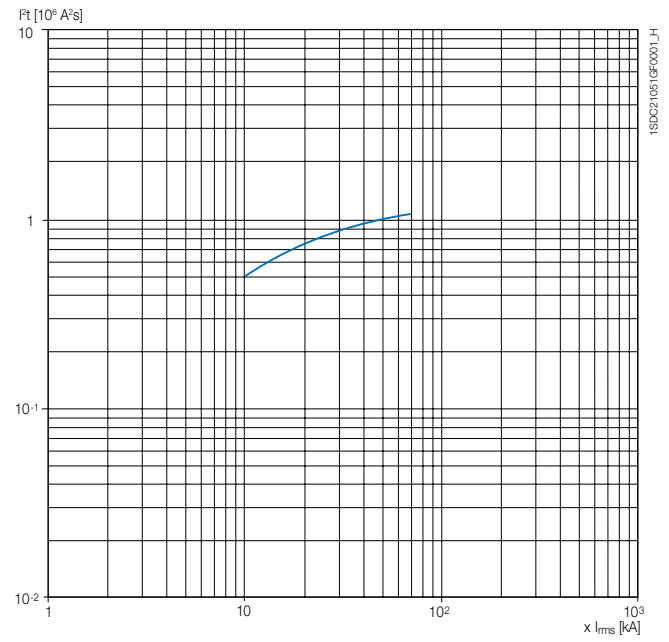

XT4V

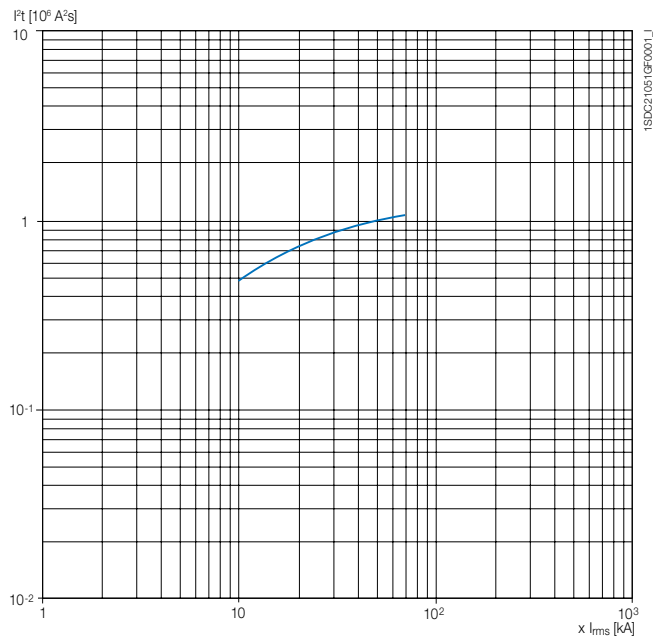

Specific let-through energy curves 600V

XT2H

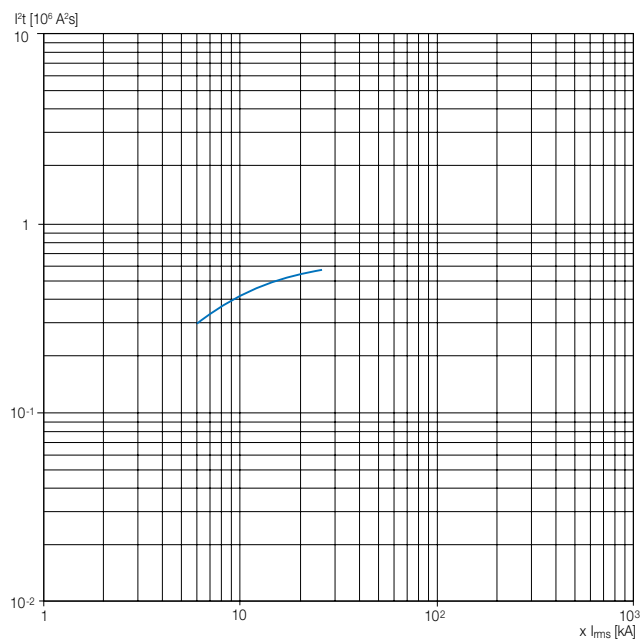

XT2L

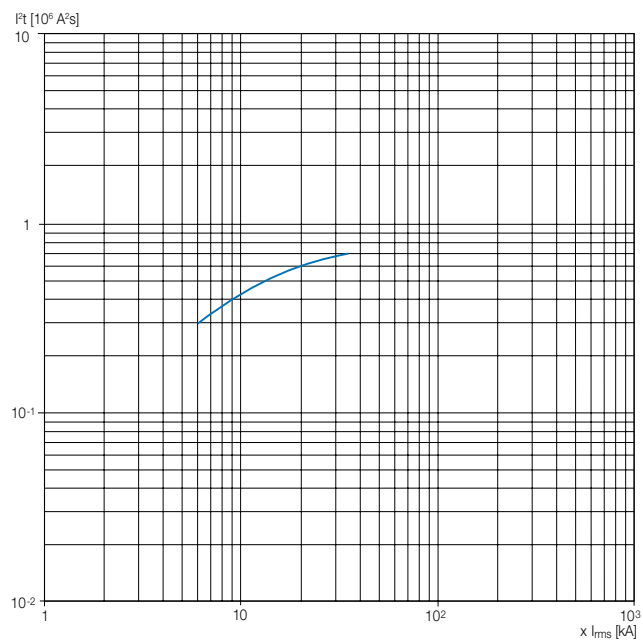

XT2V

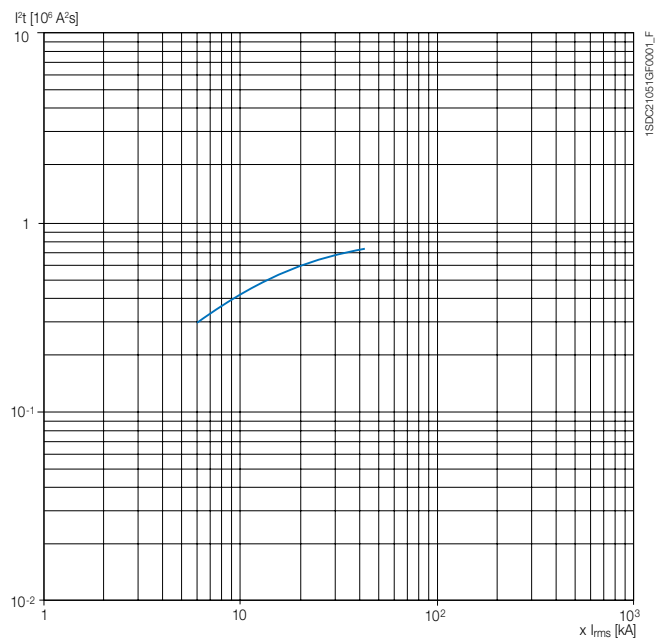

XT4H

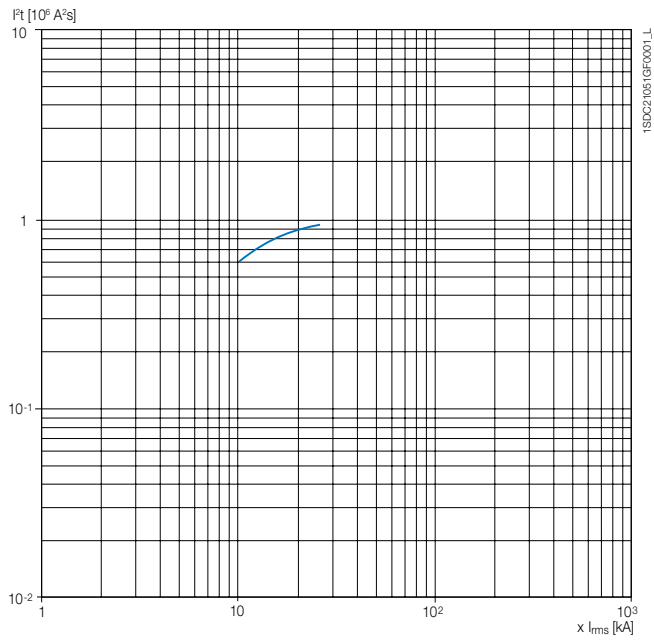

XT4L

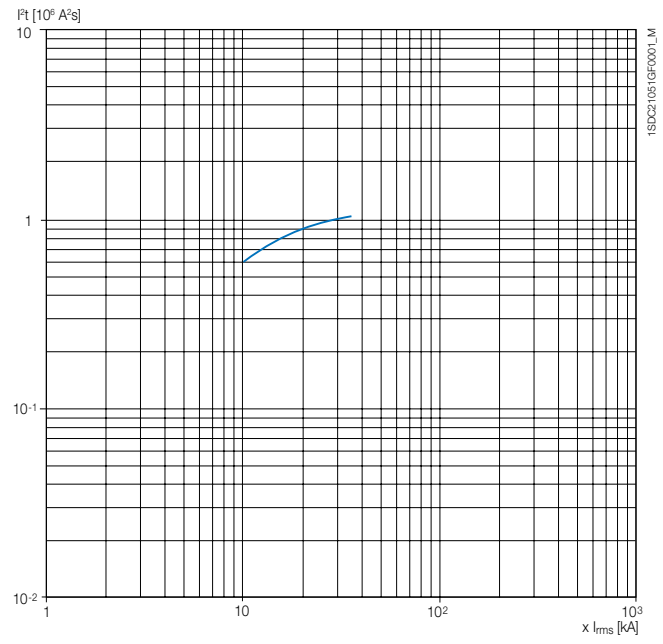

XT4V

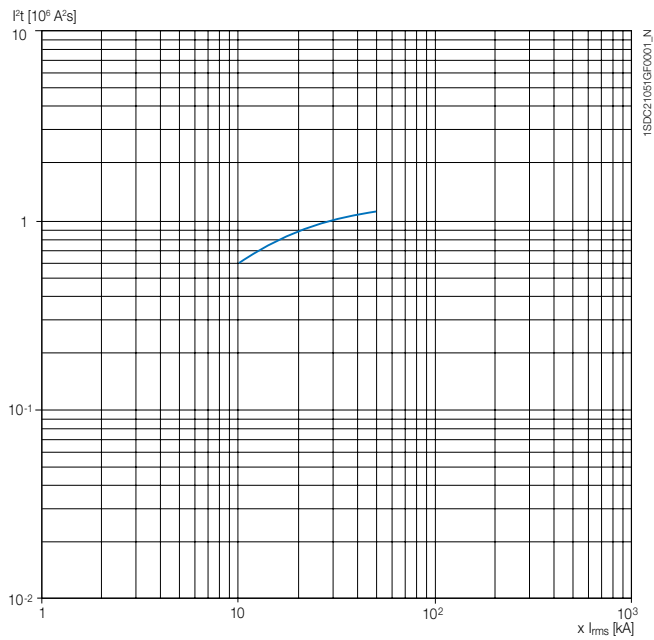

Limiting curves 480V

XT2H

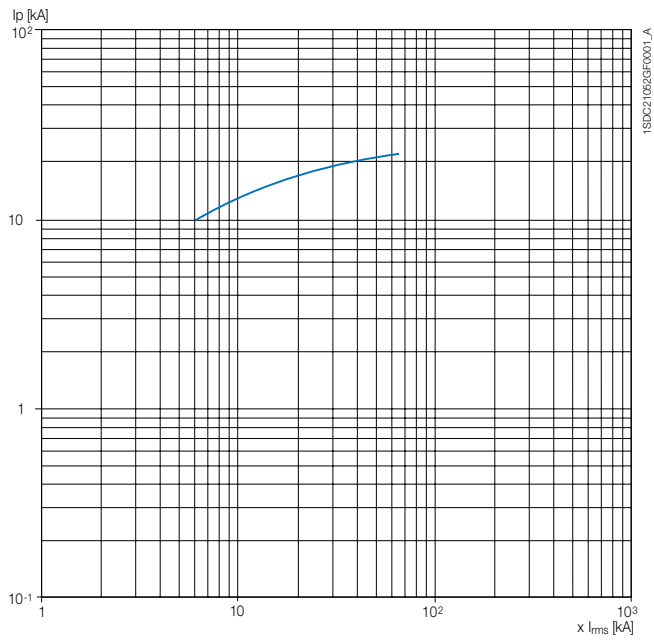

XT2L

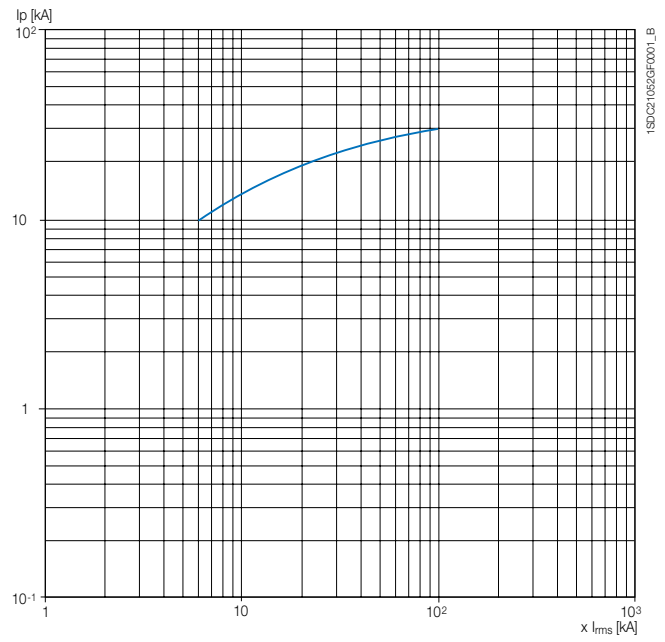

XT2V

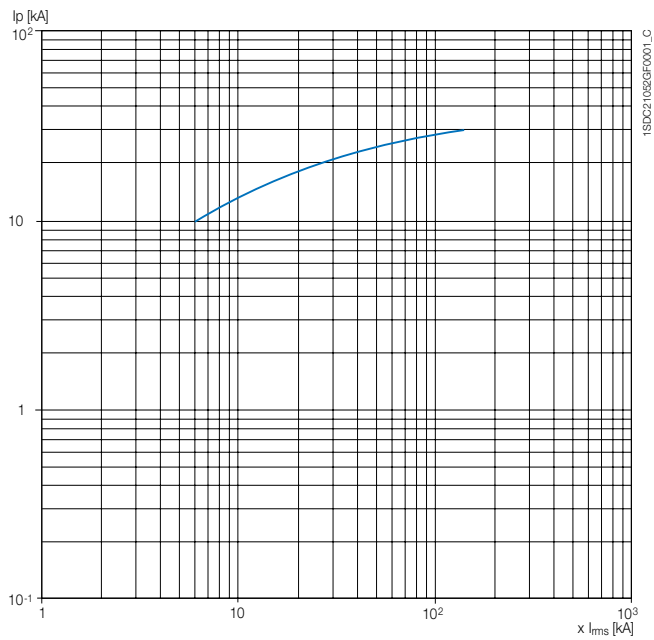

XT4H

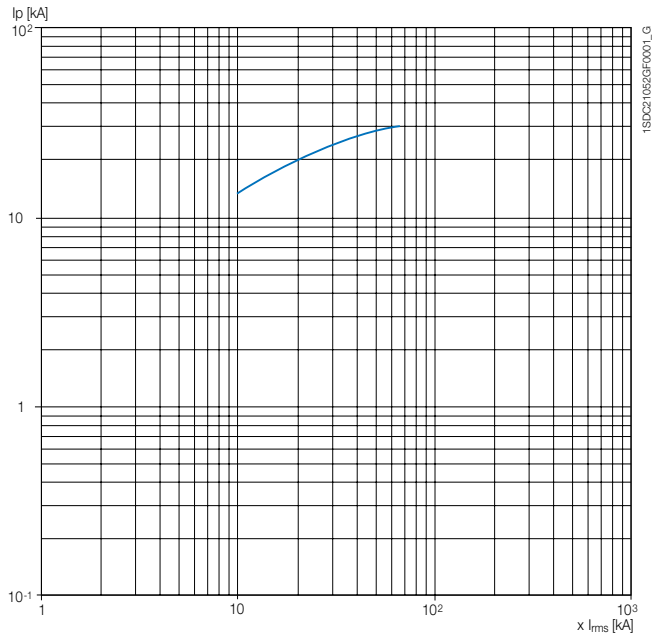

XT4L

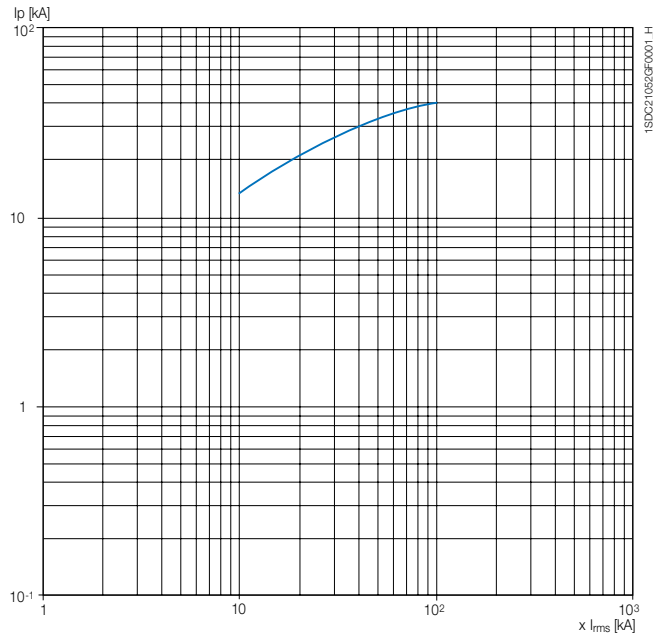

XT4V

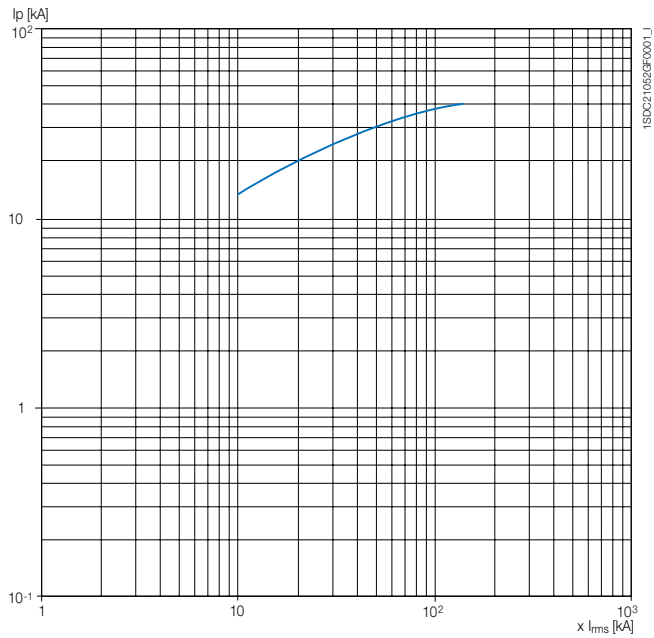

Limiting curves 600V

XT2H

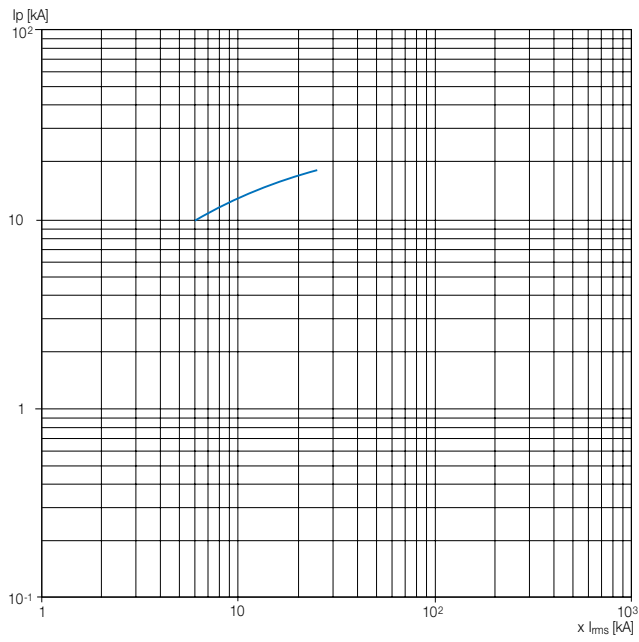

XT2L

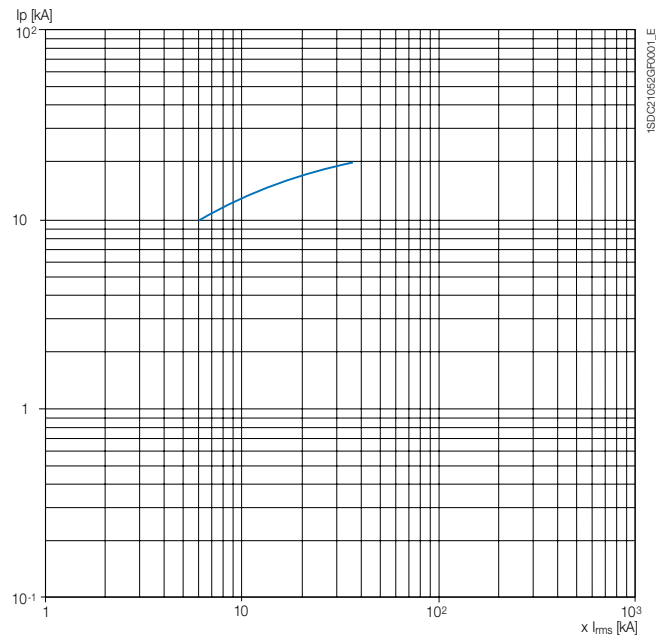

XT2V

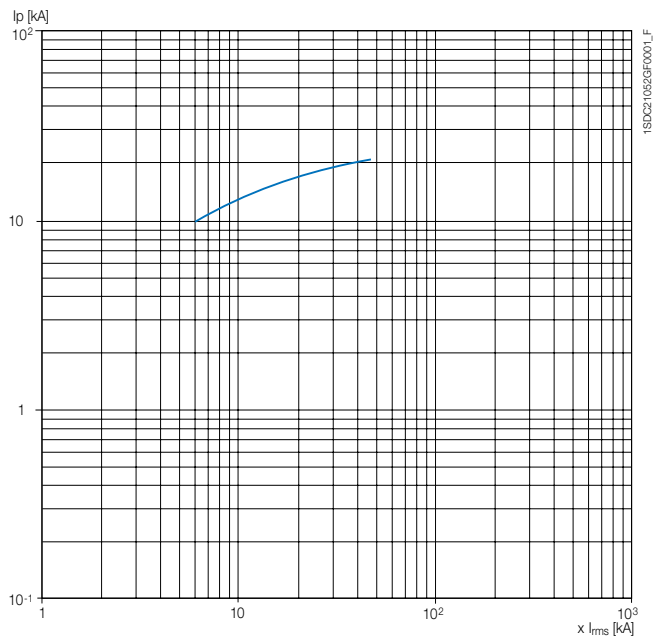

XT4H

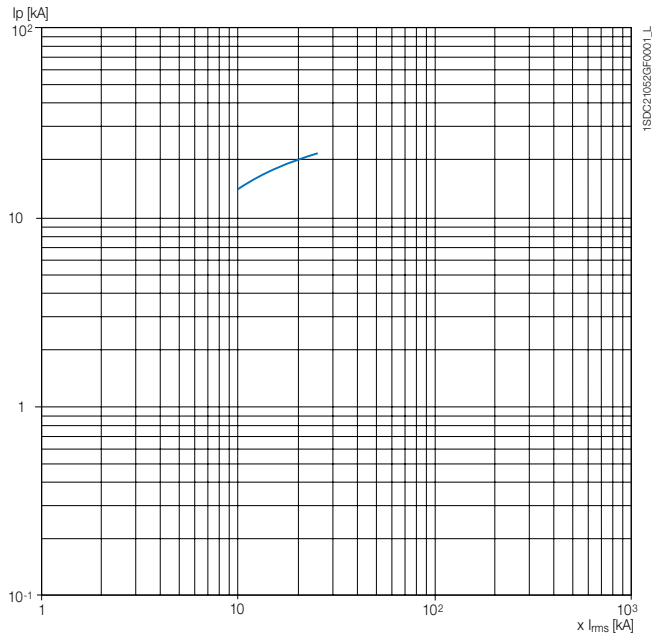

XT4L

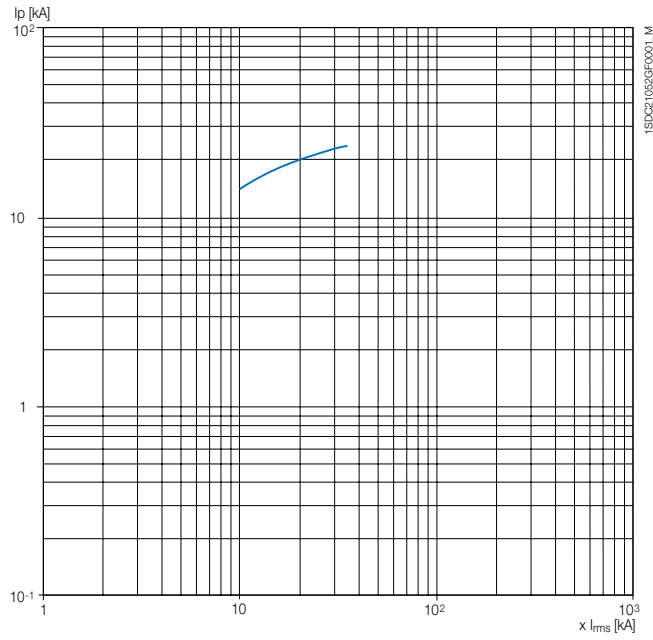

XT4V

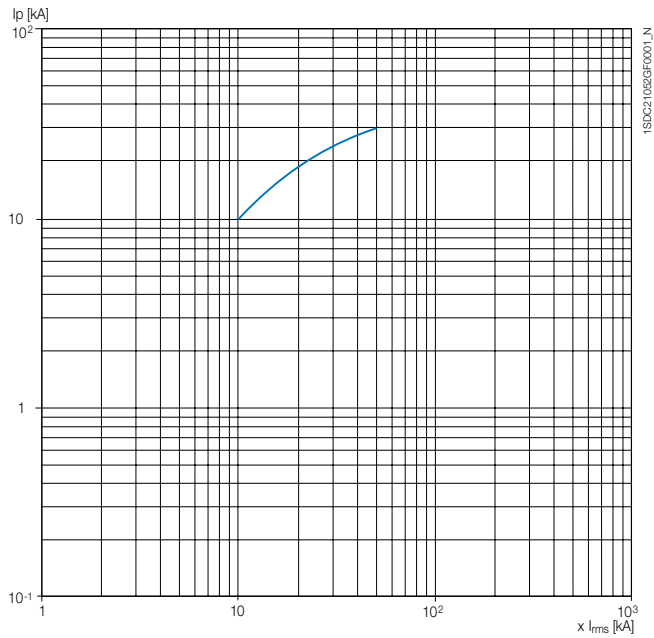

Temperature performance

All Tmax XT circuit-breakers can be used under the following environmental conditions:

- -25°C +70°C: range of atmospheric temperature where the circuit-breaker is installed;
- -40°C +70°C: range of atmospheric temperature where the circuit-breaker is stored.

Circuit-breakers fitted with a thermomagnetic trip unit have the thermal element set for a reference temperature of +40°C. With the same setting, for temperatures other than +40°C, there is a variation in the thermal trip threshold as indicated in the tables below.

XT1 - TMF

In [A]	30°C	40°C	50°C	60°C	70°C
15	16	15	14	13	12
20	21	20	19	18	16
25	26	25	23	22	20
30	32	30	28	26	24
40	42	40	38	35	33
45	48	45	42	40	37
50	53	50	47	44	41
60	63	60	56	52	49
70	74	70	66	61	57
90	95	90	85	79	73
100	105	100	94	88	81
110	115	110	103	96	90
125	131	125	117	109	102

XT2 - TMF

In [A]	30°C	40°C	50°C	60°C	70°C
15	16	15	14	13	12
20	21	20	19	17	16
25	26	25	23	22	20
30	32	30	28	26	24
35	37	35	32	31	28
40	42	40	37	35	32
50	53	50	47	43	40
60	63	60	56	52	49
70	74	70	66	61	57

XT3 - TMF

In [A]	30°C	40°C	50°C	60°C	70°C
60	63	60	56	52	49
70	74	70	66	60	56
80	84	80	75	69	64
90	95	90	84	78	72
100	105	100	93	87	80
110	116	110	102	95	88
125	132	125	116	108	100
150	158	150	140	130	121
175	185	175	163	151	141
200	211	200	186	173	161
225	237	225	210	194	181

XT4 - TMF

In [A]	30°C	40°C	50°C	60°C	70°C
25	27	25	23	21	19
30	34	30	25	23	20
32	36	32	27	24	21
35	37	35	32	30	26
40	43	40	37	34	30
50	54	50	46	42	39
60	64	60	56	51	45
63	67	63	58	53	48
70	75	70	65	58	51

XT2 - TMA

In [A]	30°C		40°C		50°C		60°C		70°C	
	MIN [A]	MAX [A]	MIN [A]	MAX [A]	MIN [A]	MAX [A]	MIN [A]	MAX [A]	MIN [A]	MAX [A]
80	59	84	56	80	53	75	49	70	46	65
90	66	95	63	90	59	84	55	78	51	73
100	74	105	70	100	65	93	61	87	57	81
110	81	116	77	110	72	103	67	96	62	89
125	92	132	88	125	82	117	76	109	71	101

XT4 - TMA

In [A]	30°C		40°C		50°C		60°C		70°C	
	MIN [A]	MAX [A]	MIN [A]	MAX [A]	MIN [A]	MAX [A]	MIN [A]	MAX [A]	MIN [A]	MAX [A]
80	60	86	56	80	52	74	46	66	41	58
90	67	95	63	90	60	86	54	77	47	68
100	74	106	70	100	67	95	60	85	53	75
110	83	118	77	110	71	101	65	92	59	84
125	94	134	88	125	81	115	74	105	67	95
150	110	158	105	150	98	141	90	128	85	122
175	129	184	123	175	116	166	107	153	98	140
200	147	210	140	200	133	190	123	175	112	160
225	168	241	158	225	146	208	133	190	119	170
250	183	262	175	250	168	240	161	230	154	220

The electronic overcurrent trip units do not undergo any variations in performance as the temperature varies.

However, even if heating does not affect the trip thresholds of the electronic trip units, in the case of temperatures exceeding +40°C, it is advisable to reduce the maximum setting for protection against overloads (L) to preserve the copper parts of the circuit-breaker against high temperatures.

The same considerations apply to the switch-disconnectors and magnetic only circuit-breakers.

The table and graph below show the maximum adjustment at which the threshold I1 of the overcurrent protection (L) must be set according to the ambient temperature and to the type of terminals used.

Temperature performance

XT2 - Fixed circuit-breakers with electronic trip unit, magnetic trip unit or switch-disconnectors

T [°C]	40°C	50°C	60°C	70°C
I _{max} [A]	125	112	97	79

XT2 Ekip - MCP - MCS

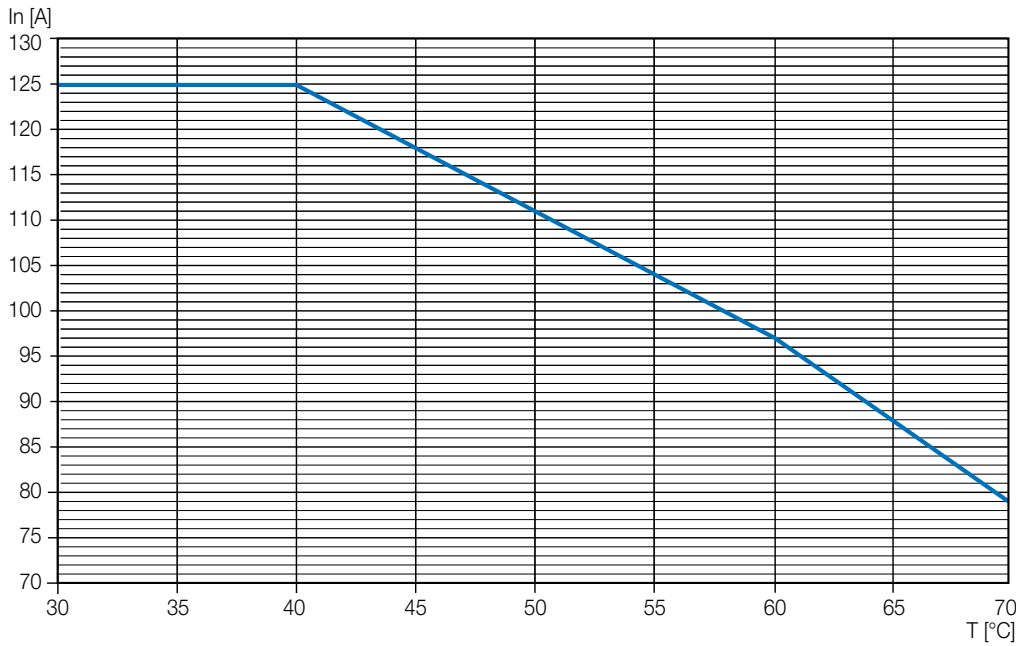

XT4 - Fixed circuit-breakers with electronic trip unit, magnetic trip unit or switch-disconnectors

T [°C]	40°C	50°C	60°C	70°C
I _{max} [A]	250	224	194	158

XT4 Ekip - MCP - MCS

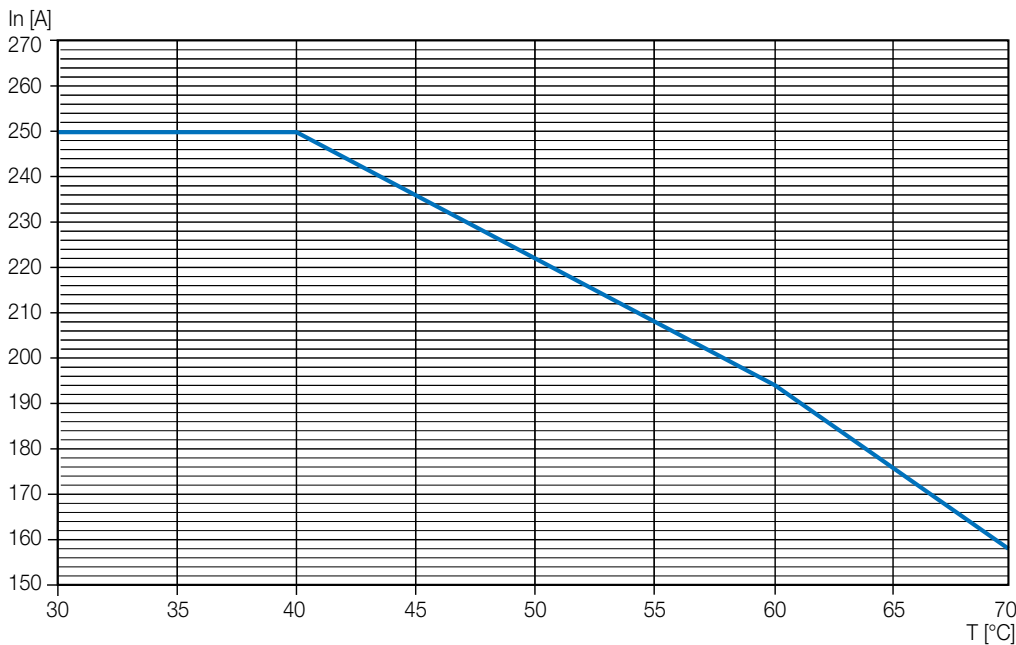

XT1 - Fixed circuit-breakers with electronic trip unit, magnetic trip unit or switch-disconnectors

T [°C]	40°C	50°C	60°C	70°C
I _{max} [A]	125	112	97	79

XT1 MCS - MCP

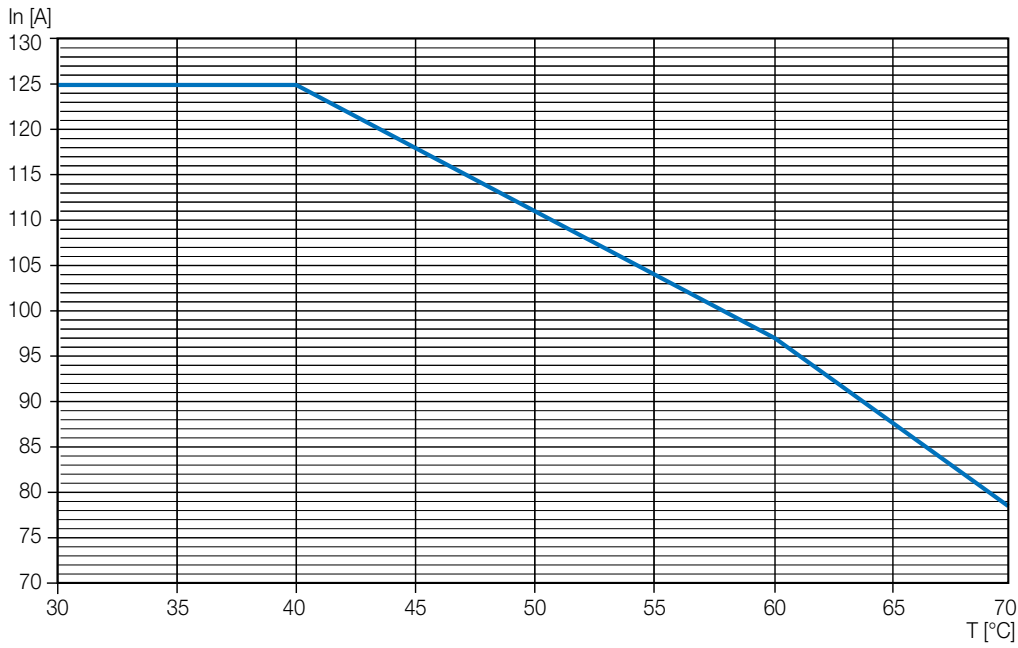

XT3 - Fixed circuit-breakers with electronic trip unit, magnetic trip unit or switch-disconnectors

T [°C]	40°C	50°C	60°C	70°C
I _{max} [A]	225	201	174	142

XT3 MCS - MCP

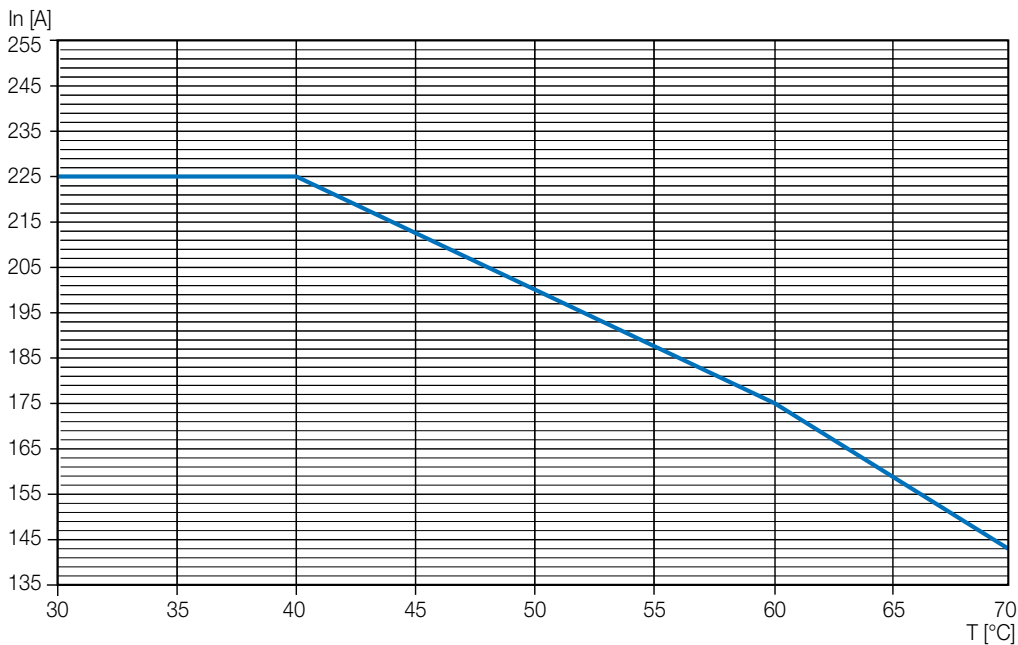

Dissipated powers

4

Molded case circuit breakers

Trip unit	In [A]	XT1 [W/pole]	XT2 [W/pole]	XT3 [W/pole]	XT4 [W/pole]
TM	15	1.3	1.1	-	-
	20	1.8	1.6	-	-
	25	2.0	1.8	-	2.7
	30	1.8	2.3	-	3.9
	35	2.0	2.8	-	4.4
	40	2.6	3.7	-	4.5
	45	3.0	-	-	-
	50	3.7	4.1	-	4.7
	60	3.9	4.4	3.9	4.8
	70	3.7	4.4	3.7	5.4
	80	4.8	5.8	4.8	5.5
	90	5.7	6.6	4.5	6.0
	100	7.0	8.1	5.6	6.2
	110	8.3	8.8	5.8	6.7
	125	10.7	11.4	6.6	7.4
	150	-	-	6.9	7.8
	160	-	-	7.9	8.9
	175	-	-	10.1	9.1
	200	-	-	13.2	11.9
	225	-	-	14.4	13.3
250	-	-	-	16.4	
Ekip LS/I	10	-	0.1	-	-
Ekip I	25	-	0.8	-	-
Ekip LSI	40	-	-	-	0.6
Ekip LSIg	60	-	1.5	-	1.3
Ekip E-LSIG	100	-	4.2	-	3.5
	125	-	6.6	-	-
	150	-	-	-	7.8
	225	-	-	-	13.3
	250	-	-	-	16.4

Values refers to fixed version

Motor protection

In [A]	XT1 [W/pole]	XT2 [W/pole]	XT3 [W/pole]	XT4 [W/pole]
3	1.4	3.7	-	-
7	3.2	9.3	-	-
15	1.1	6.4	-	-
25	-	-	-	2.6
30	2.3	3.8	-	-
50	3.1	5	-	6.8
70	5.3	5.5	-	-
80	5.3	6.8	-	5.5
100	6.6	8.1	4.5	6.2
110	-	-	3.3	6.7
125	10.3	14	4.1	7.4
150	-	-	6.5	7.8
175	-	-	-	9.1
200	-	-	8.6	11.9
225	-	-	-	13.3
250	-	-	-	16.4

Values refers to fixed version

Overall dimensions

Tmax XT1

Installation for fixed circuit breaker	5/2
Terminals for fixed circuit breaker	5/5
Accessories for fixed circuit breaker	5/8
Installation for plug-in circuit breaker	5/16
Terminals for plug-in circuit breaker	5/19
Accessories for plug-in circuit breaker	5/23

Tmax XT2

Installation for fixed circuit breaker	5/24
Terminals for fixed circuit breaker	5/27
Accessories for fixed circuit breaker	5/30
Installation for plug-in circuit breaker	5/36
Terminals for plug-in circuit breaker	5/38
Accessories for plug-in circuit breaker	5/42
Installation for withdrawable circuit breaker	5/46
Terminals for withdrawable circuit breaker	5/49
Accessories for withdrawable circuit breaker	5/54

Tmax XT3

Installation for fixed circuit breaker	5/58
Terminals for fixed circuit breaker	5/61
Accessories for fixed circuit breaker	5/65
Installation for plug-in circuit breaker	5/68
Terminals for plug-in circuit breaker	5/74
Accessories for plug-in circuit breaker	5/77

Tmax XT4

Installation for fixed circuit breaker	5/78
Terminals for fixed circuit breaker	5/81
Accessories for fixed circuit breaker	5/85
Installation for plug-in circuit breaker	5/91
Terminals for plug-in circuit breaker	5/95
Accessories for plug-in circuit breaker	5/99
Installation for withdrawable circuit breaker	5/103
Terminals for withdrawable circuit breaker	5/105
Accessories for withdrawable circuit breaker	5/109

Tmax XT - Common accessories	5/111
Distances to be respected	5/113

Overall dimensions

Tmax XT1 - Installation for fixed circuit breaker

Mounting on the backplate

Captions

- ① Insulating plate (compulsory)
- ② Overall dimension of optional wiring ducts
- ③ 25mm insulating barriers between phases (compulsory) provided
- ④ Front carter obligatory for through door of the panel $\leq 25\text{mm}/0,98''$

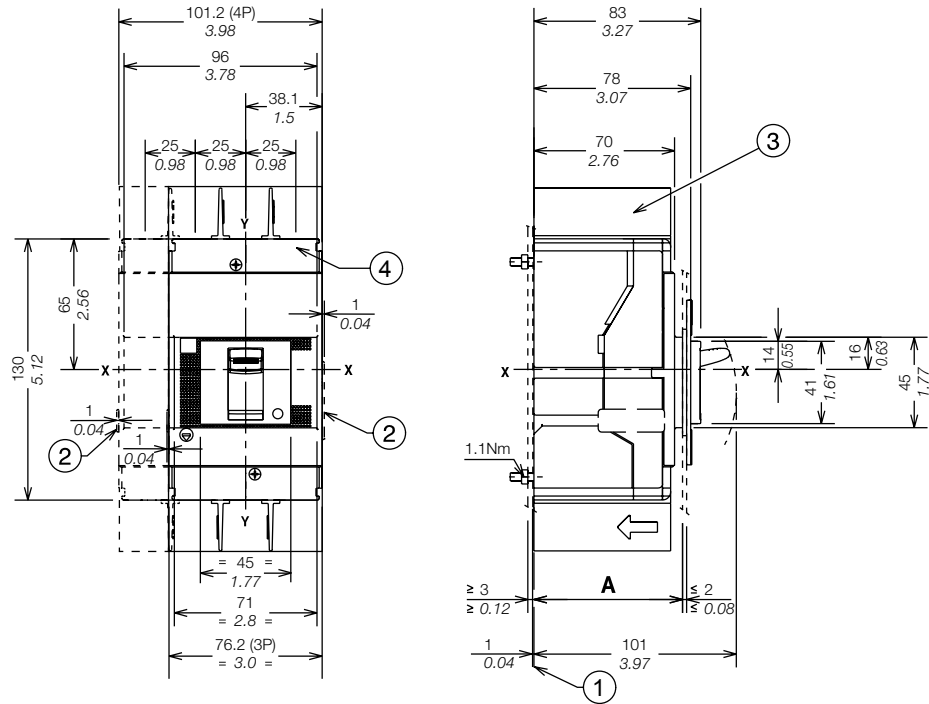

		A
With standard flange	III - IV	74
Without flange	III - IV	71
	III - IV	79

Mounting on DIN 50022 rail

Captions

- ① Mounting bracket
- ② Overall dimension of optional wiring ducts
- ③ 25mm insulating barriers between phases (compulsory) provided
- ④ Optional front cover for DIN rail
- ⑤ Insulating plate (compulsory)

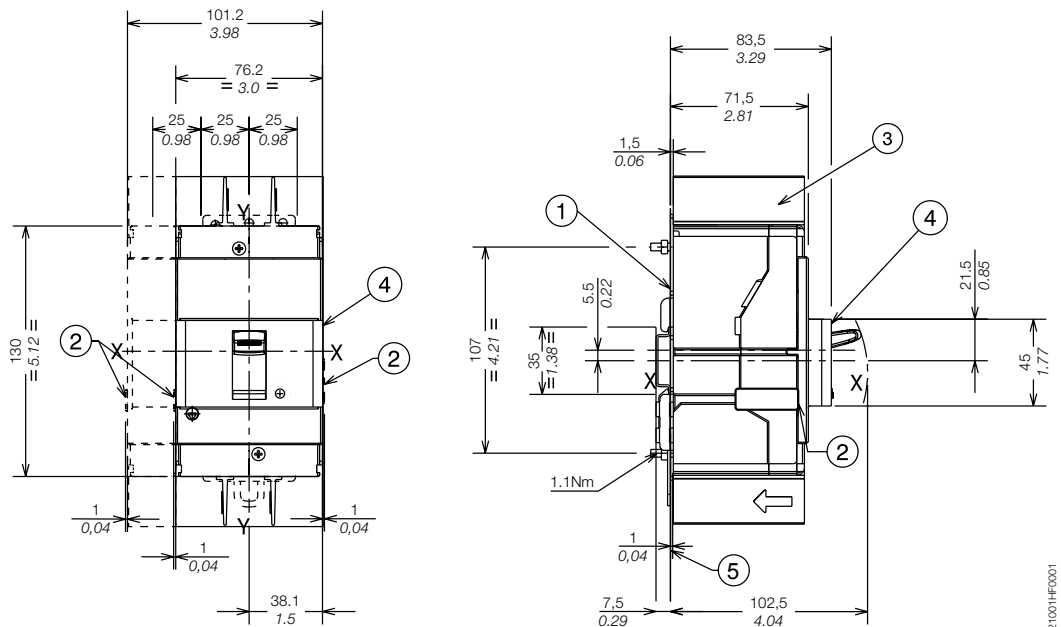

Drilling template for circuit breaker mounting

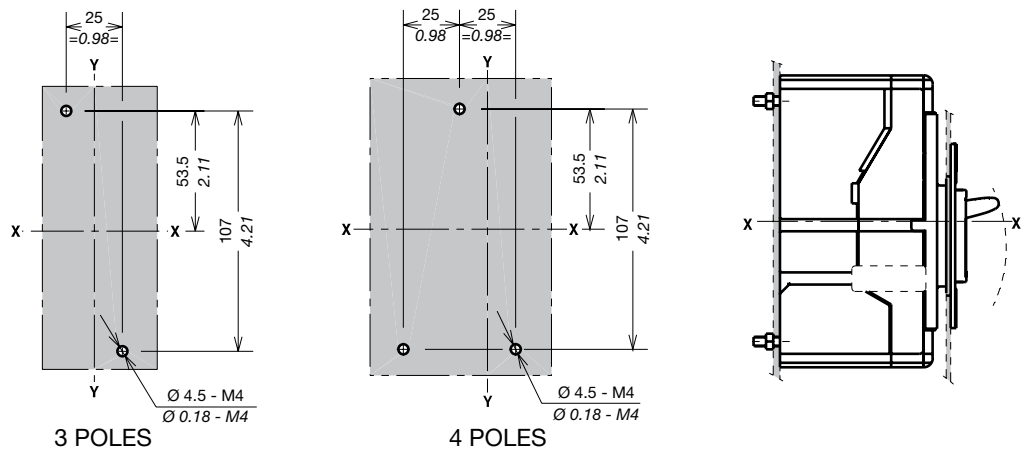

1SD021002HF0001

Flanges

Captions

- ① Flange for circuit breaker III
- ② Flange for circuit breaker IV
- ③ Flange for fixed III-IV with direct motor operator (MOD)
- ④ Flange for III-IV with direct rotary handle (RHD)
- ⑤ Optional flange

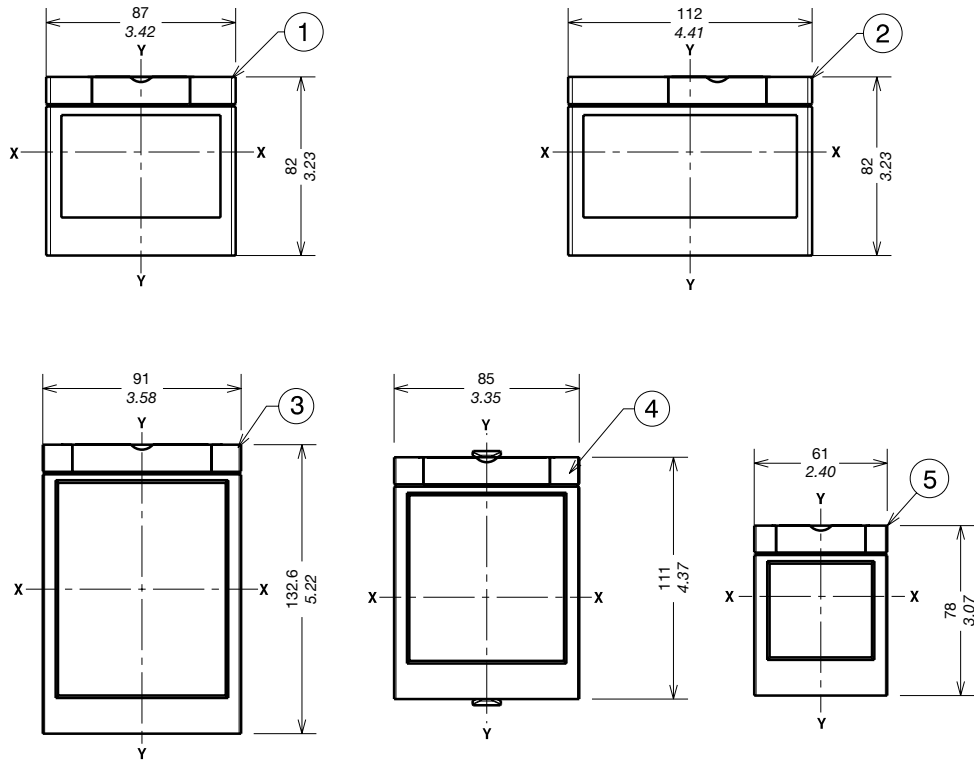

1SD021009HF0001

Overall dimensions

Tmax XT1 - Installation for fixed circuit breaker

Drilling templates for compartment door

With standard flange

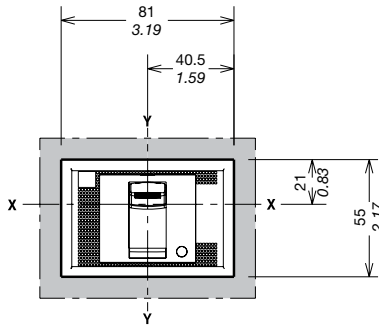

A=74
3 POLES

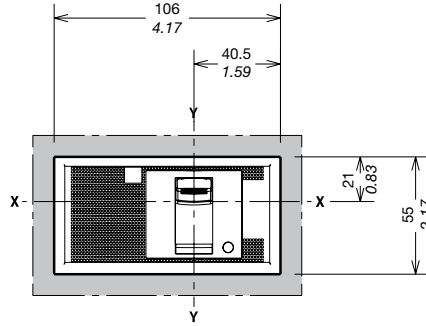

A=74
4 POLES

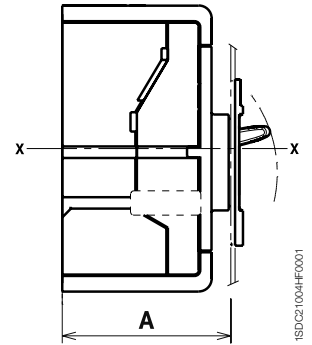

1SDC21004HF0001

Without flange

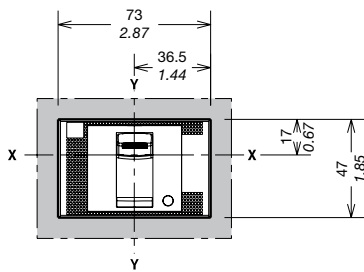

A=71
3 POLES

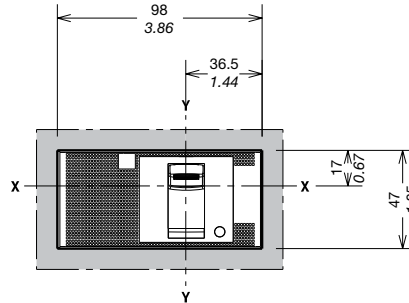

A=71
4 POLES

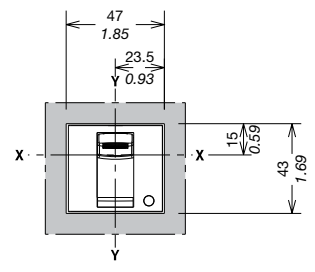

A=79
3-4 POLES

1SDC21005HF0001

With optional flange

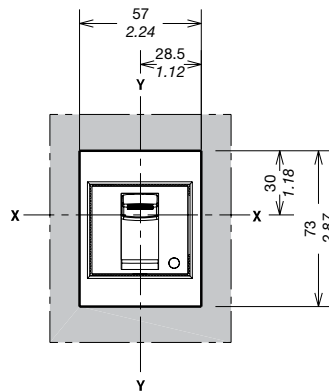

A=79
3-4 POLES

1SDC21006HF0001

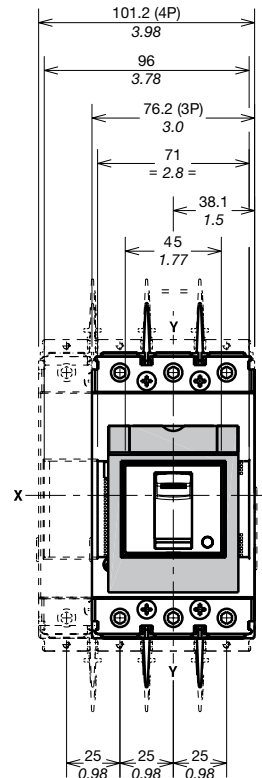

1SDC21007HF0001

Overall dimensions

Tmax XT1 - Terminals for fixed circuit breaker

Terminals F

Captions

- ① Front terminals for busbar connection
- ⑦ 25mm insulating barriers between phases (compulsory) provided

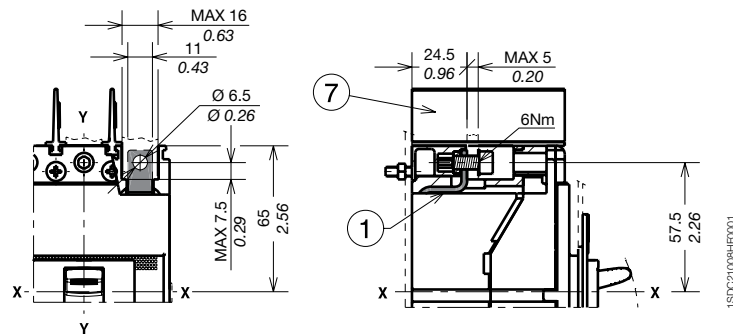

Terminals EF

Captions

- ② Front extended terminals
- ③ High terminal covers with degree of protection IP40 (optional) not provided
- ⑤ 100mm insulating barriers between phases (compulsory) provided
- ⑨ Internal insulating plate compulsory with phase barriers (customer)

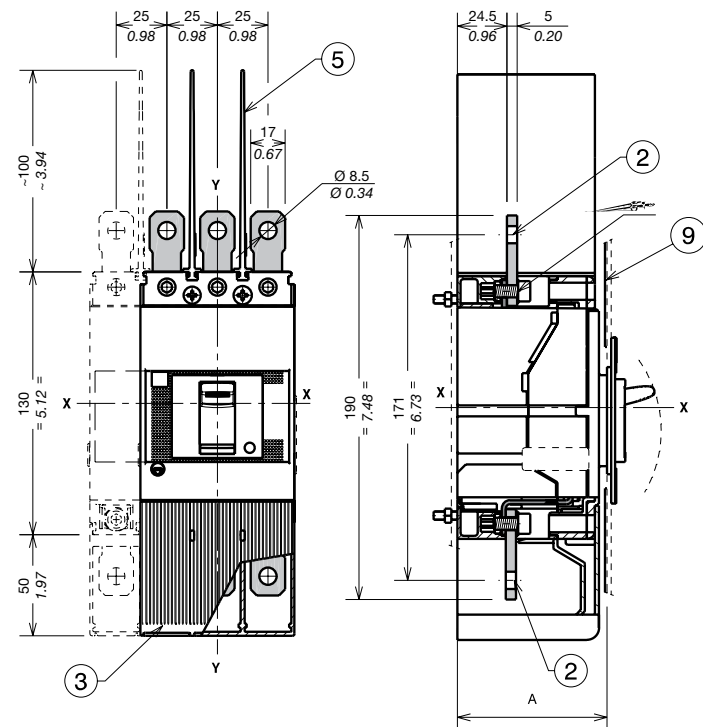

Terminals ES

Captions

- ④ Front extended spread terminals for busbar connection
- ⑥ 200mm insulating barriers between phases (compulsory) provided

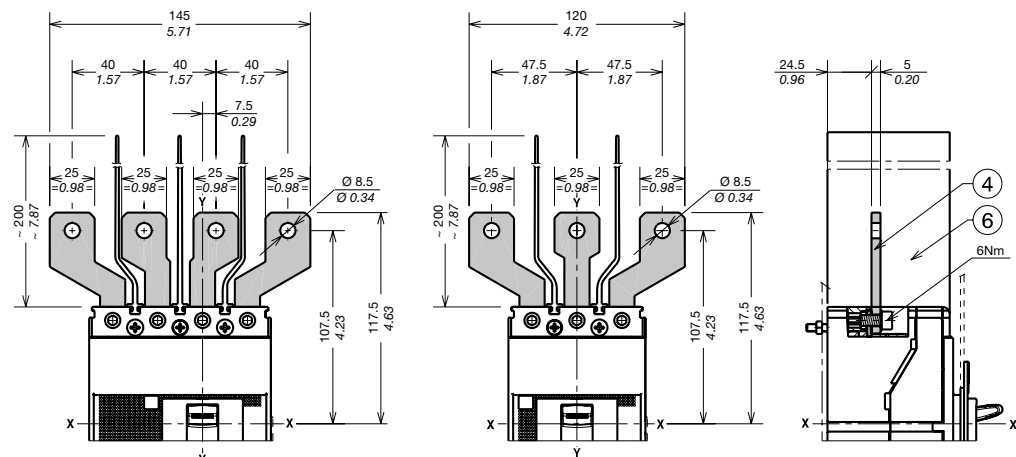

Overall dimensions

Tmax XT1 - Terminals for fixed circuit breaker

Terminals FCCu

Captions

- ② Front terminal FCCu

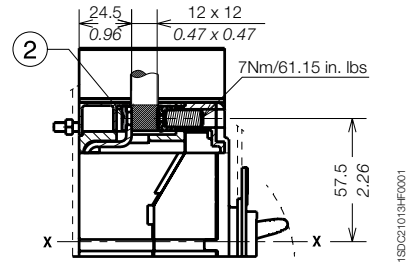
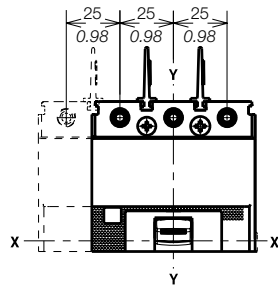

5

Terminals MC

Captions

- ④ Terminal covers with degree of protection IP40 (compulsory) provided
- ⑤ Front terminal for multi-cable connection

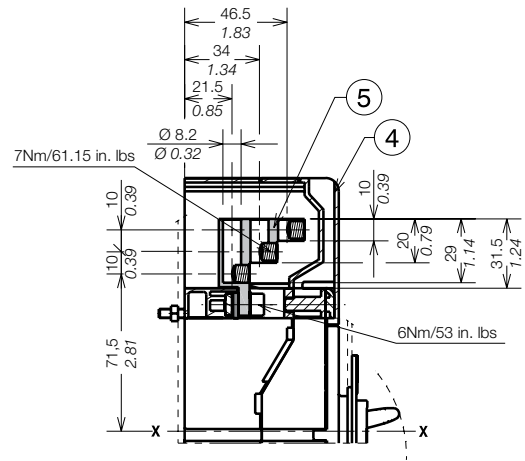
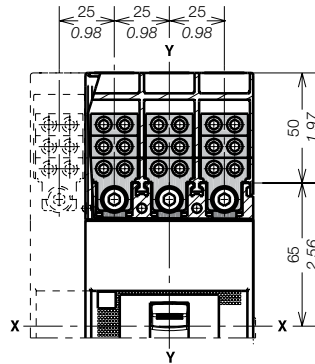

Terminals R

Captions

- ① Adjustable rear terminals
- ② Bottom terminal covers with degree of protection IP30 (optional) not provided
- ③ Drilling template for mounting circuit breaker III on sheet
- ④ Drilling template for mounting circuit breaker IV fixing on sheet

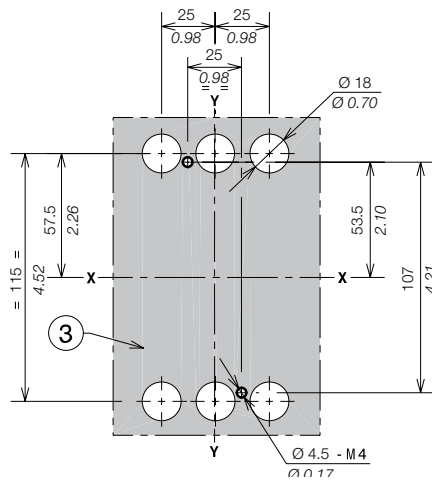
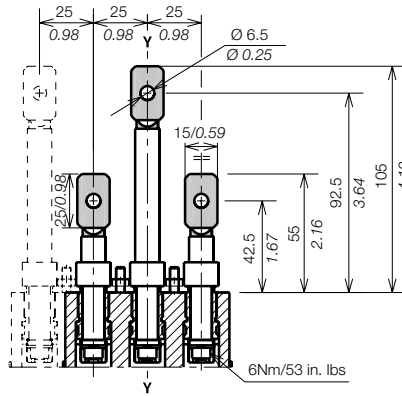
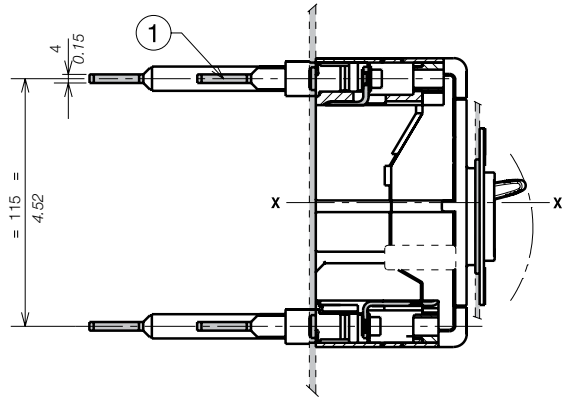
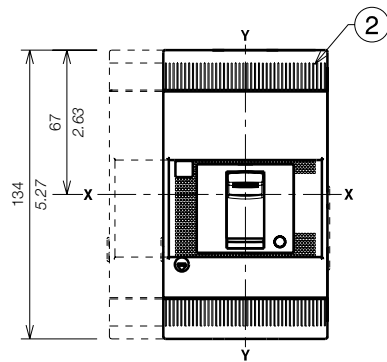

3 POLES

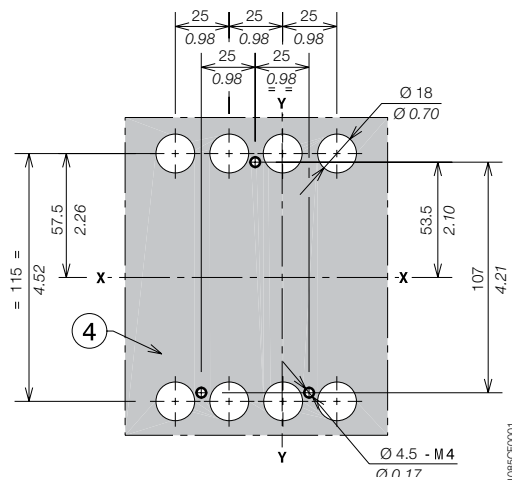

4 POLES

1SD211085CF0001

Overall dimensions

Tmax XT1 - Accessories for fixed circuit breaker

Rotary handle operating mechanism on circuit breakers (RHD)

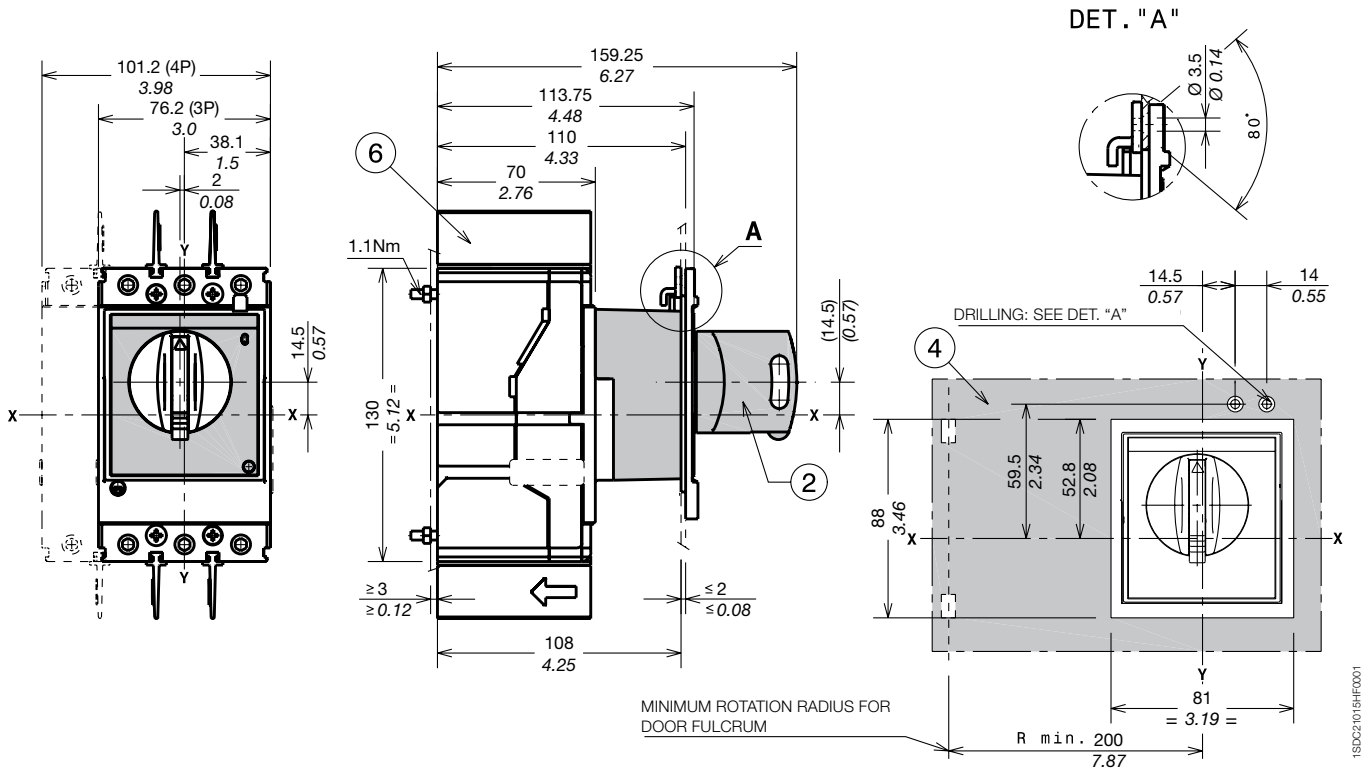

Captions

- ② Rotary handle operating mechanism on circuit breaker RHD
- ④ Door drilling template with direct rotary handle
- ⑥ 25mm insulating barriers between phases (compulsory) provided

Rotary handle operating mechanism on the compartment door (RHE)

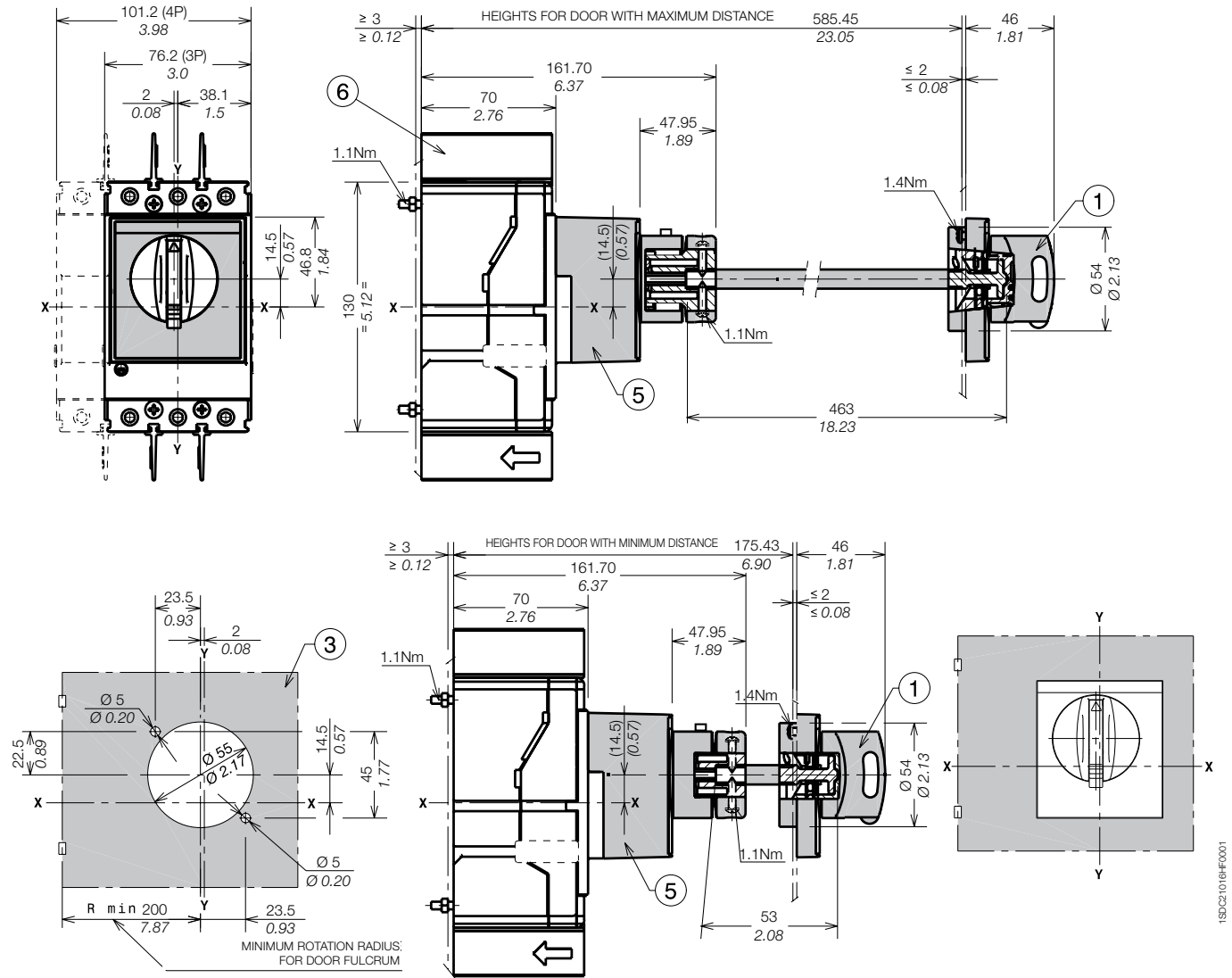

Captions

- ① Transmitted rotary handle
- ③ Door drilling template with transmitted rotary handle
- ⑤ Transmission unit
- ⑥ 25mm insulating barriers between phases provided with circuit breaker

Overall dimensions

Tmax XT1 - Accessories for fixed circuit breaker

Large rotary handle operating mechanism on the compartment door (RHE-LH)

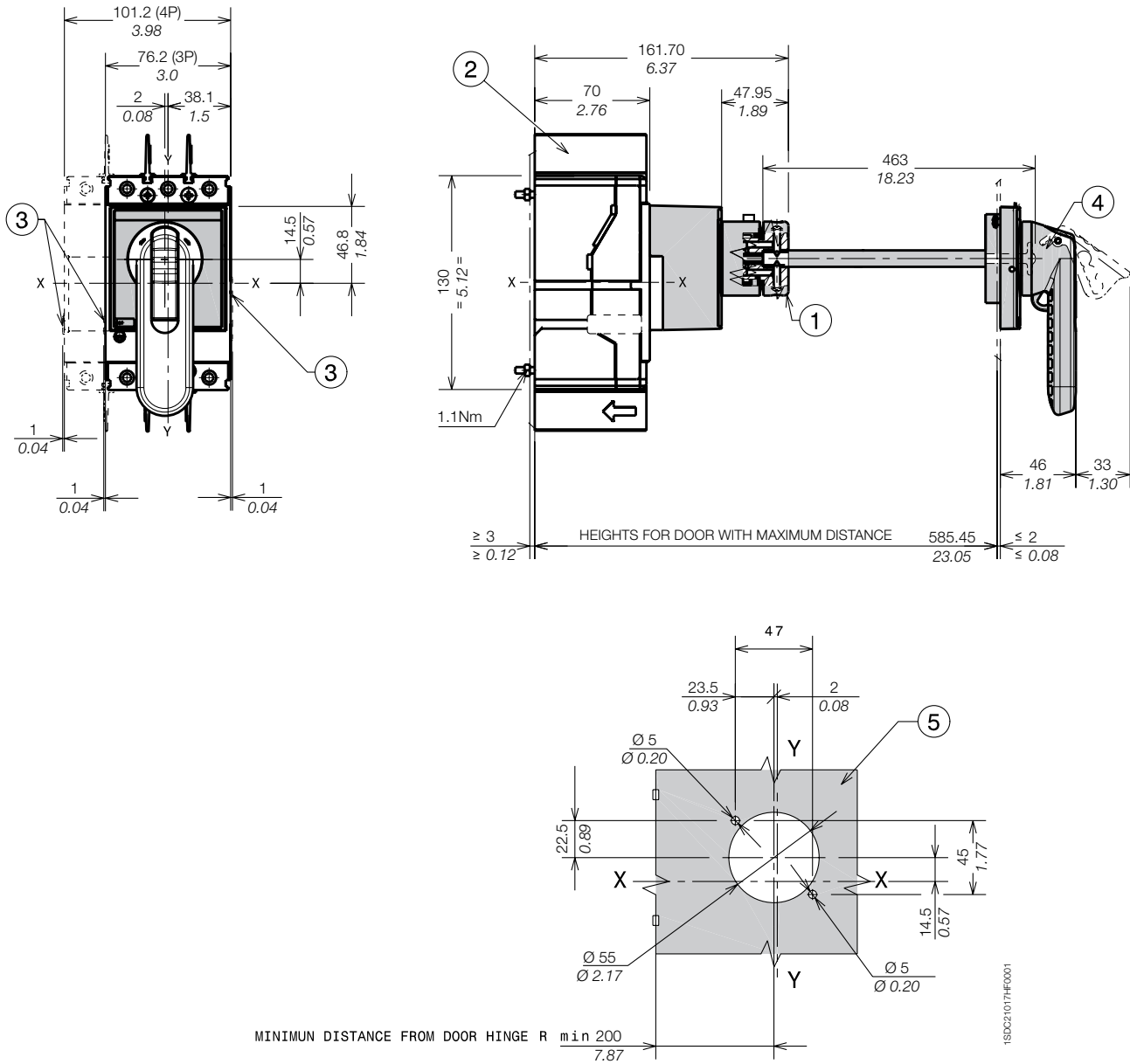

Captions

- ① Transmission unit
- ② 25mm insulating barriers between phases provided with circuit breaker
- ③ Optional wiring ducts
- ④ Wide type rotary handle
- ⑤ Door drilling template with extended rotary handle

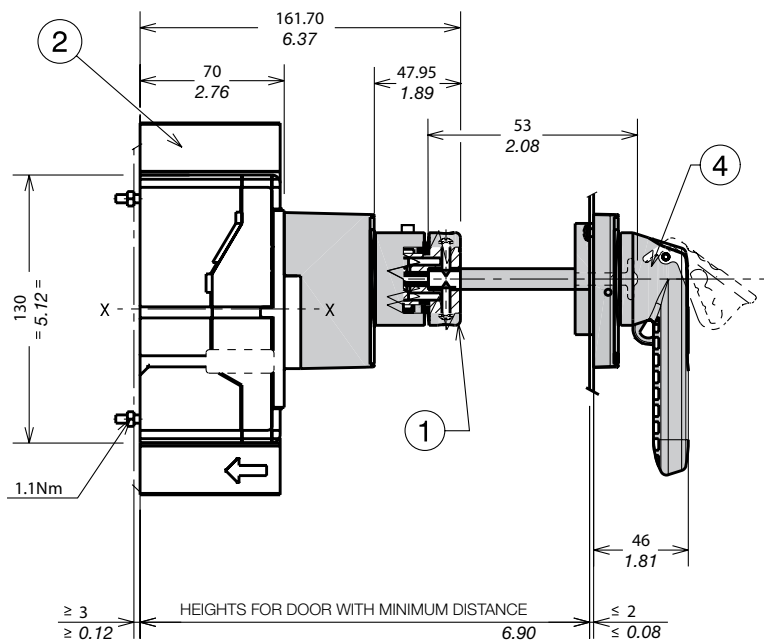
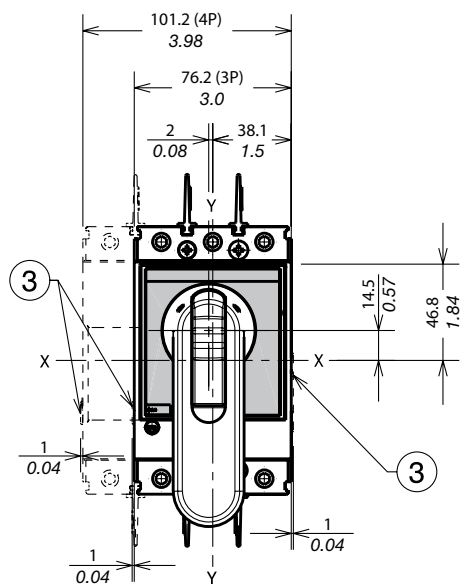

1SD021018HF0001

Captions

- ① Transmission unit
- ② 25mm insulating barriers between phases (compulsory) provided
- ③ Optional wiring ducts
- ④ Wide type rotary handle

Overall dimensions

Tmax XT1 - Accessories for fixed circuit breaker

Direct motor operator (MOD)

Captions

- ③ Key lock (not provided)
- ④ Direct motor operator (MOD)
- ⑤ Drilling template of door with MOD without flange
- ⑥ Drilling template of door with MOD with flange
- ⑦ Cable connections
- ⑧ 25mm phase barriers

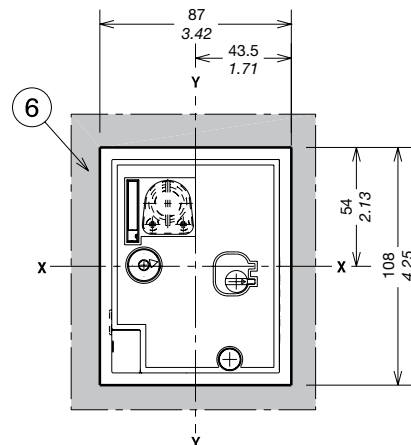
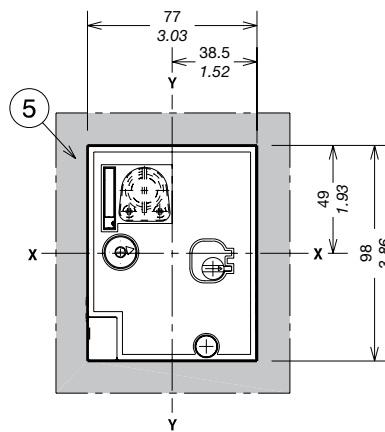
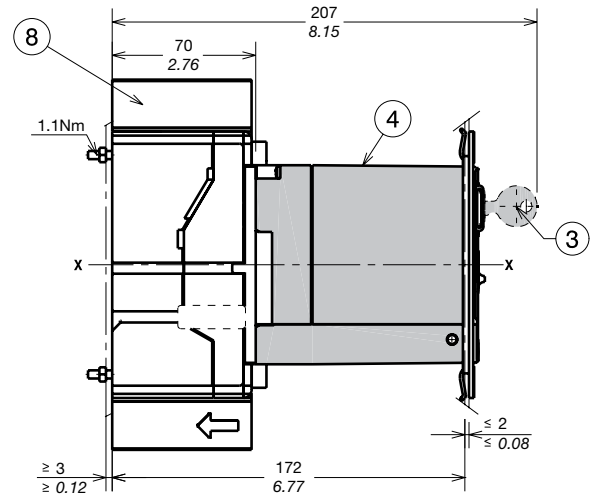
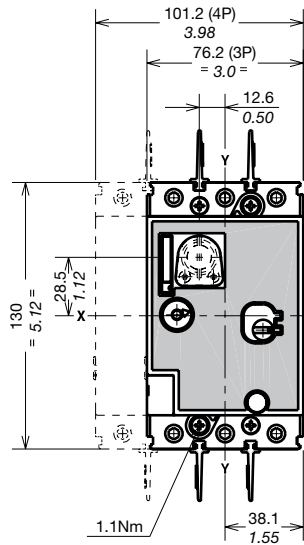

1SDC21019HF001

1SDC21020HF001

RC Inst and RC Sel residual current release for 3-pole circuit breaker

Captions

- ① Front terminals for busbar connection
- ② Terminal covers with degree of protection IP40
- ③ Drilling template of door with direct rotary handle with flange
- ④ Drilling template of door with direct rotary handle without flange
- ⑤ Drilling template for mounting circuit breaker on sheet

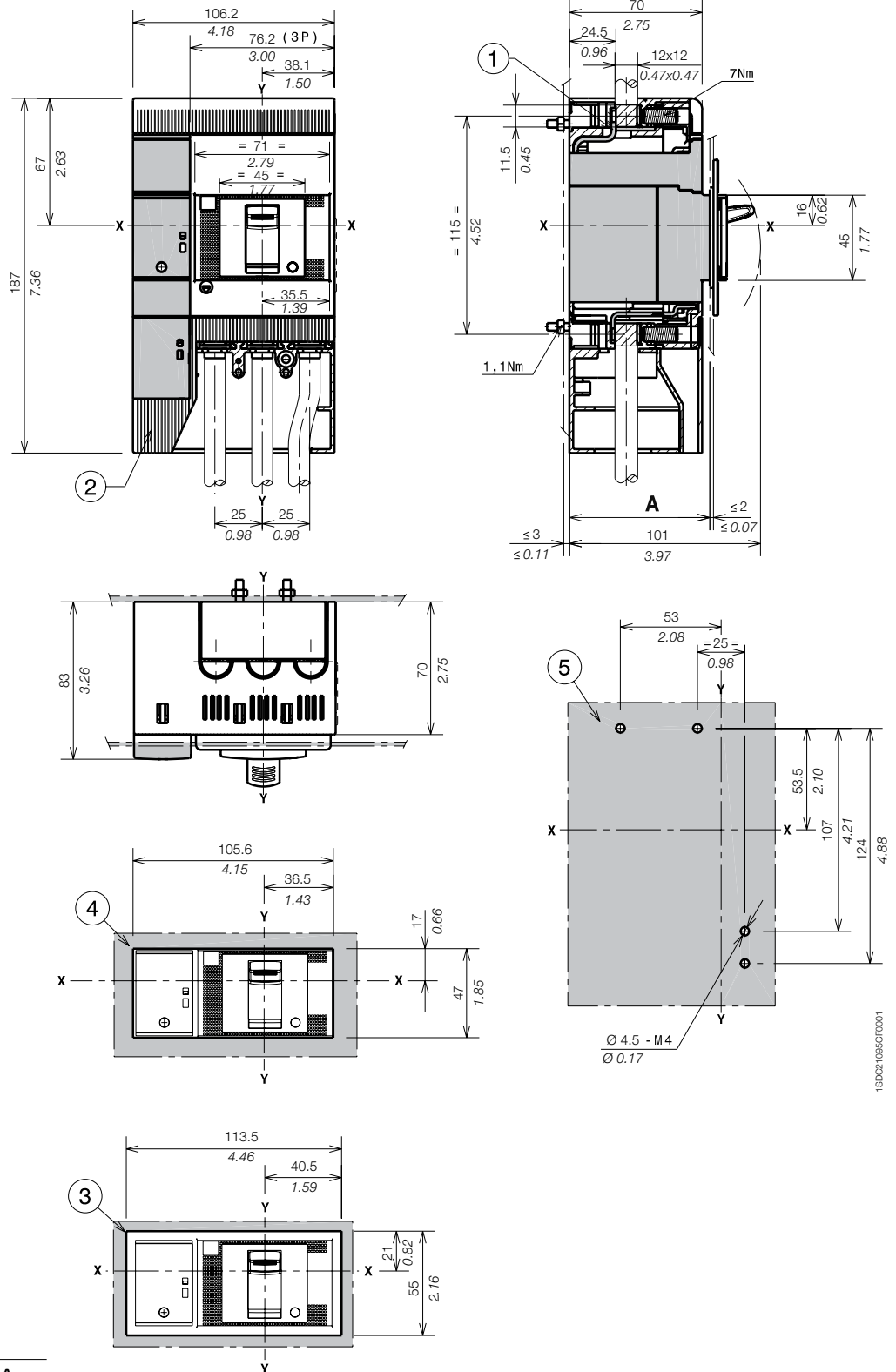

		A
With standard flange	III	74
Without flange	III	71

Overall dimensions

Tmax XT1 - Accessories for fixed circuit breaker

RC Inst and RC Sel residual current release for 4-pole circuit breaker

Captions

- ① Front terminals for busbar connection
- ② Terminal covers with degree of protection IP40
- ③ Drilling template of door with direct rotary handle with flange
- ④ Drilling template of door with direct rotary handle without flange
- ⑤ Drilling template for mounting circuit breaker on sheet

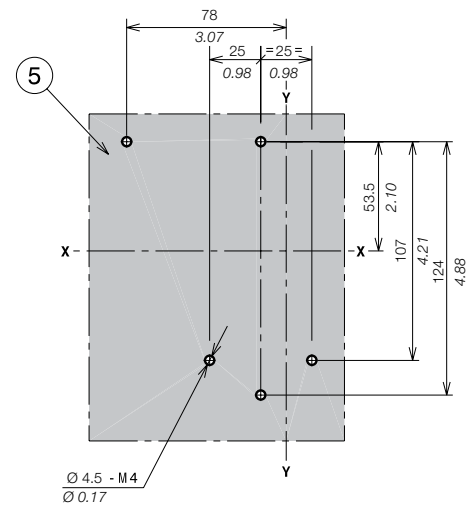
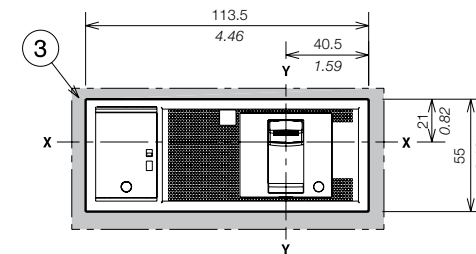
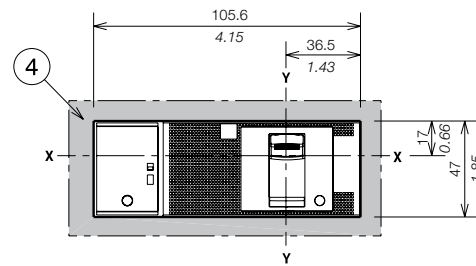
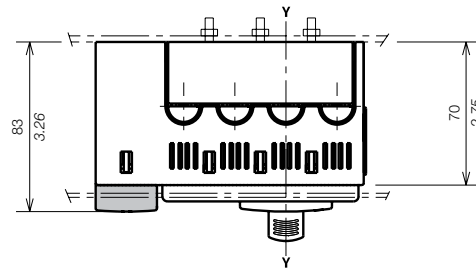
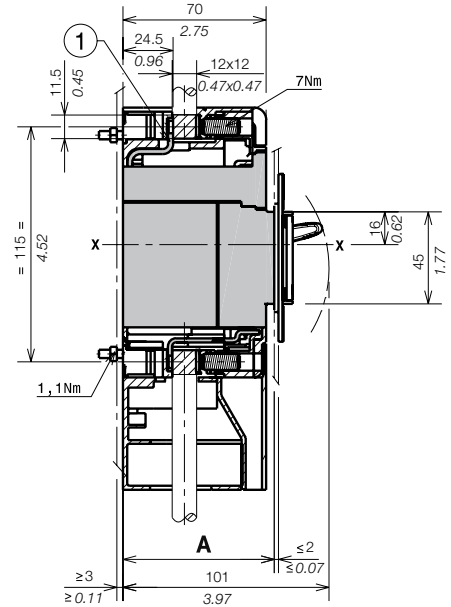
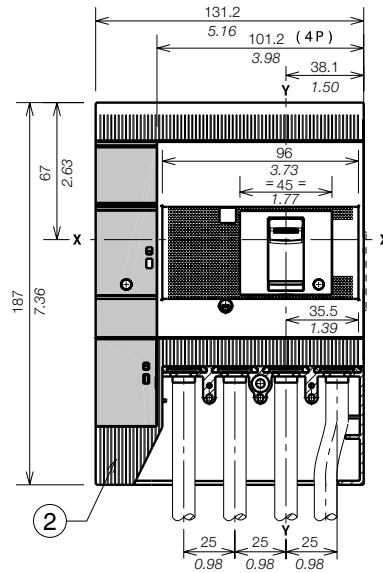

1SDC21096CF0001

		A
With standard flange	IV	74
Without flange	IV	71

RC Sel 200 4-pole residual current release

Captions

- ① Front terminals for busbar connection
- ② Terminal covers with degree of protection IP40
- ③ Drilling template of door with direct rotary handle
- ④ Drilling template for mounting circuit breaker on sheet

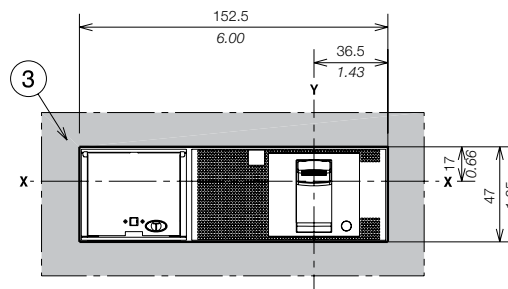
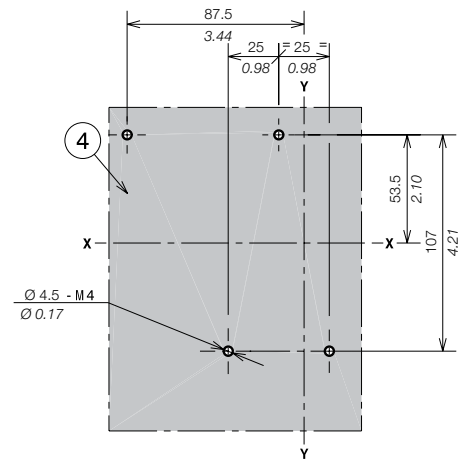
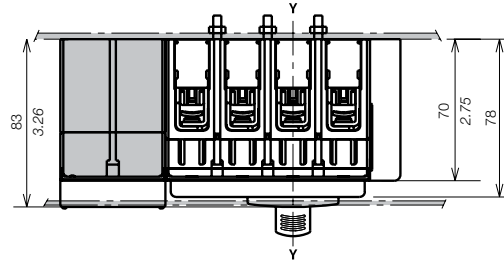
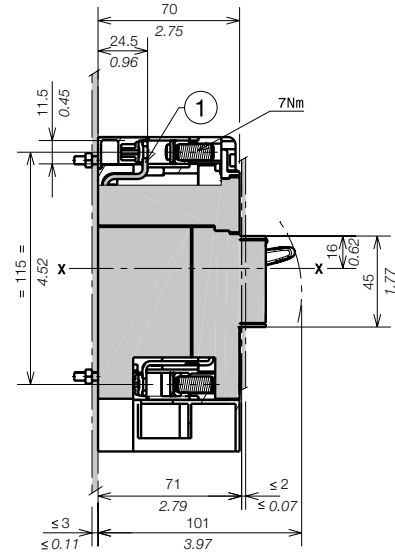
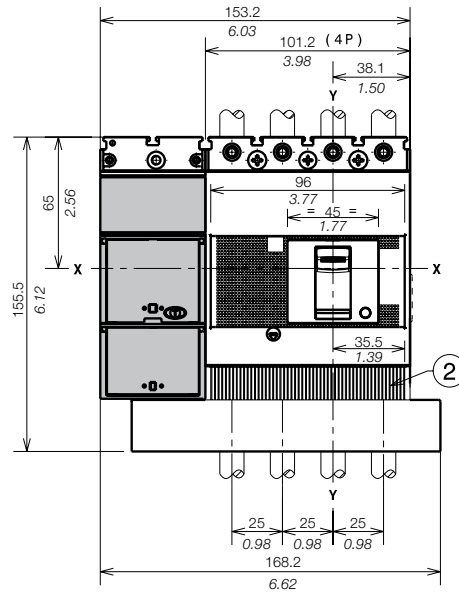

1SXU21087CF0001

Overall dimensions

Tmax XT1 - Installation for plug-in circuit breaker

Mounting on the backplate

Captions

- ① Fixed part
- ② Moving part

Fixing at 50mm		A
With standard flange	III - IV	124
Without flange	III - IV	121
	III - IV	129

Fixing at 70mm for extended front terminals		A
With standard flange	III - IV	144
Without flange	III - IV	141
	III - IV	149

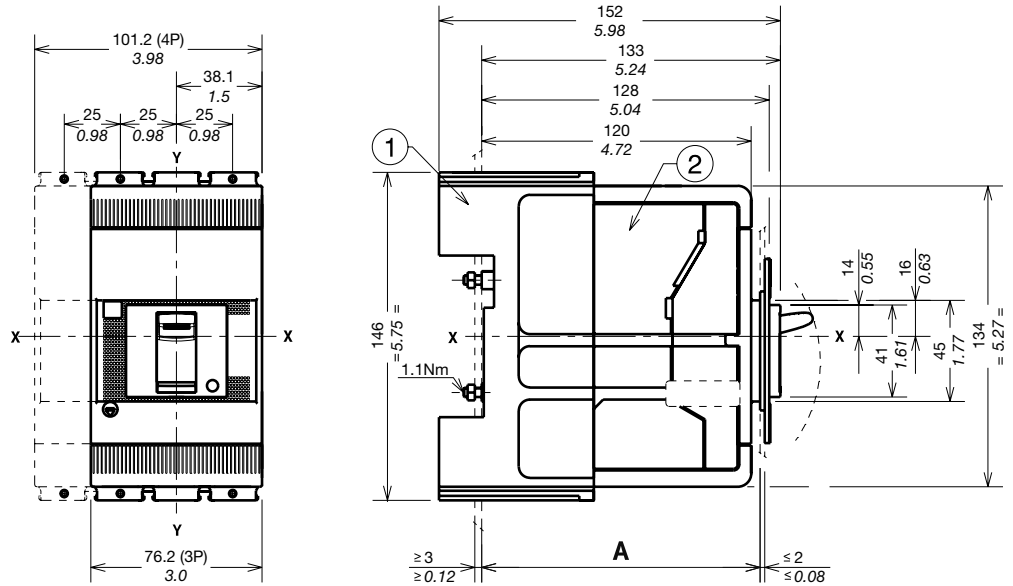

Drilling template for mounting circuit breaker

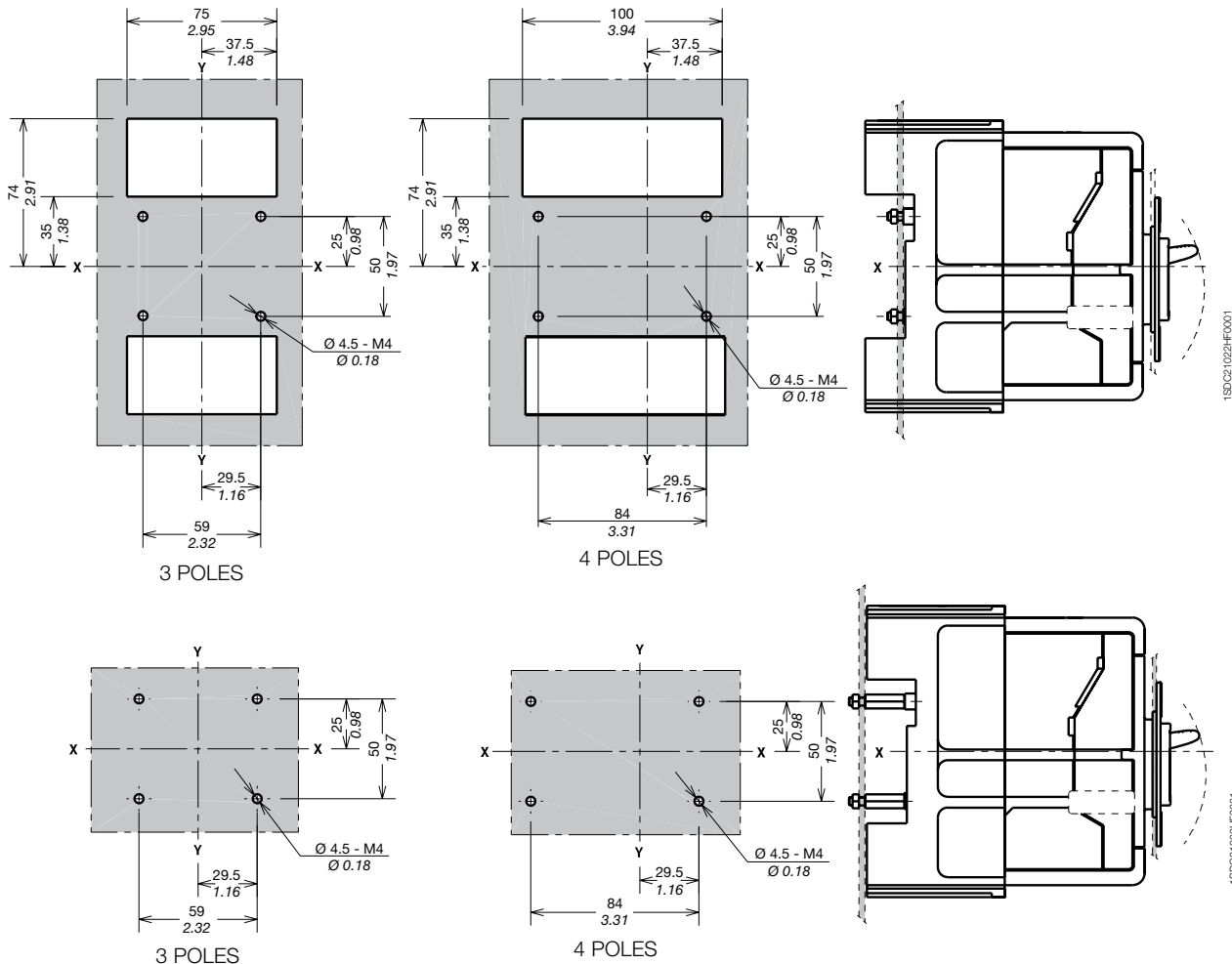

Flanges

Captions

- ① Flange for plug-in circuit breaker III
- ② Flange for circuit breaker IV
- ⑤ Flange for plug-in circuit breaker III-IV with direct motor operator (MOD)
- ⑥ Flange for plug-in circuit breaker III-IV with direct rotary handle RHD
- ⑦ Optional flange

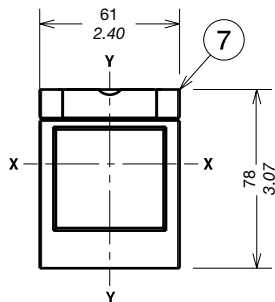
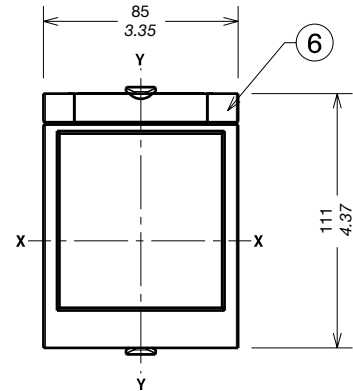
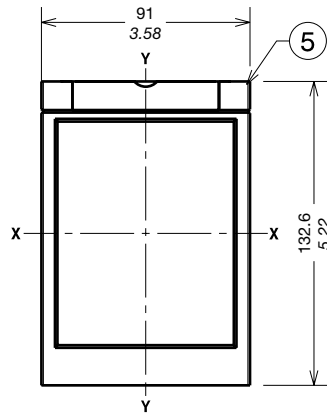
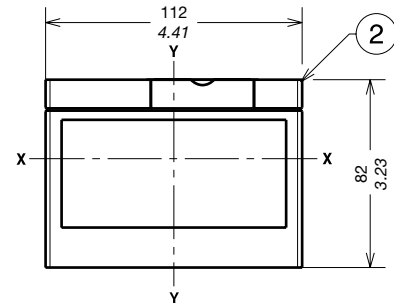
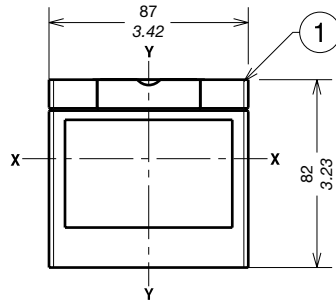

1SDXC2102#F0001

Overall dimensions

Tmax XT1 - Installation for plug-in circuit breaker

Drilling templates for compartment door

With standard flange

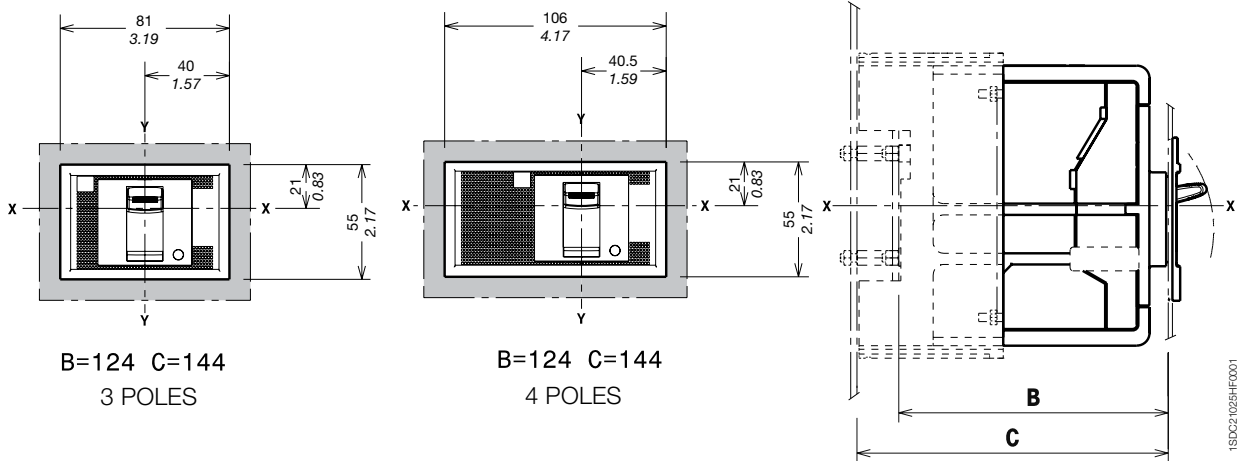

Without flange

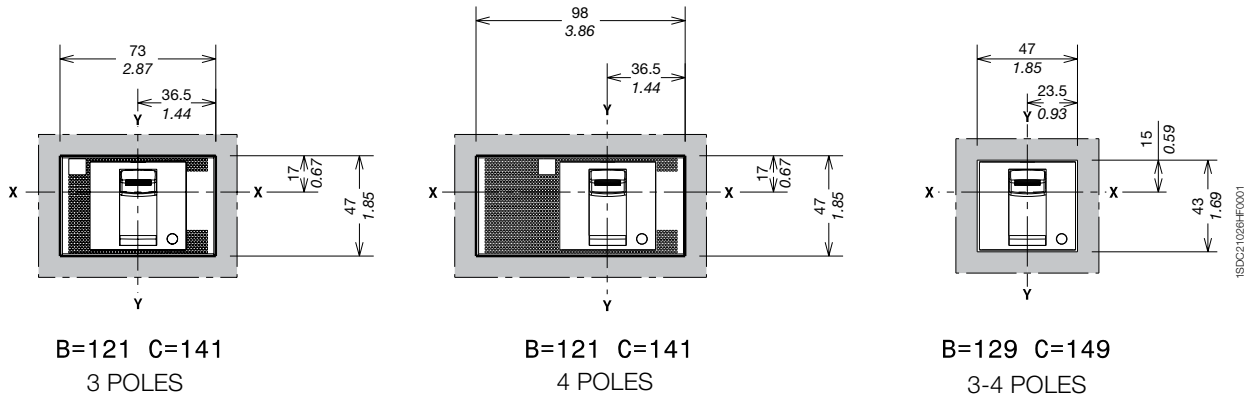

With optional flange

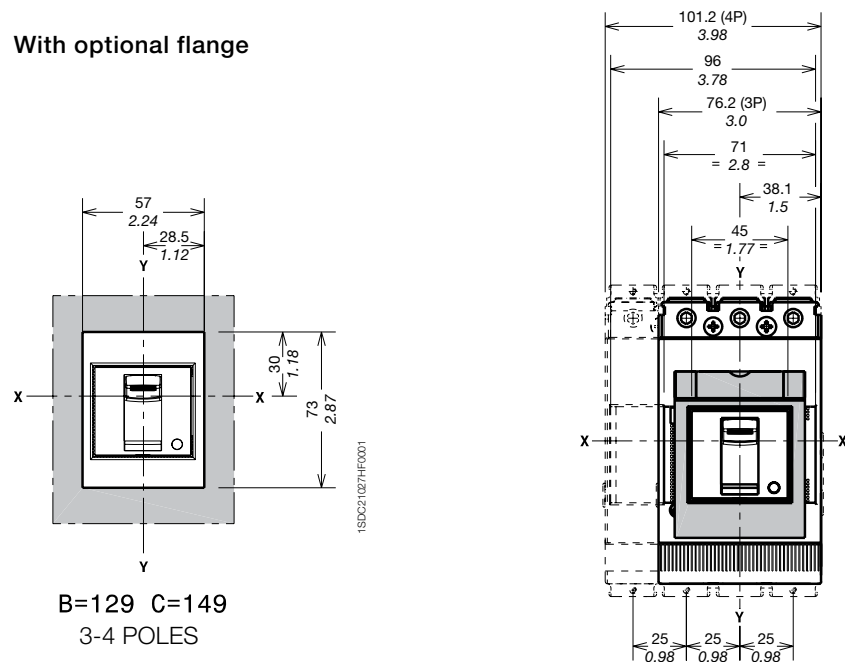

Overall dimensions

Tmax XT1 - Terminals for plug-in circuit breaker

Terminals EF

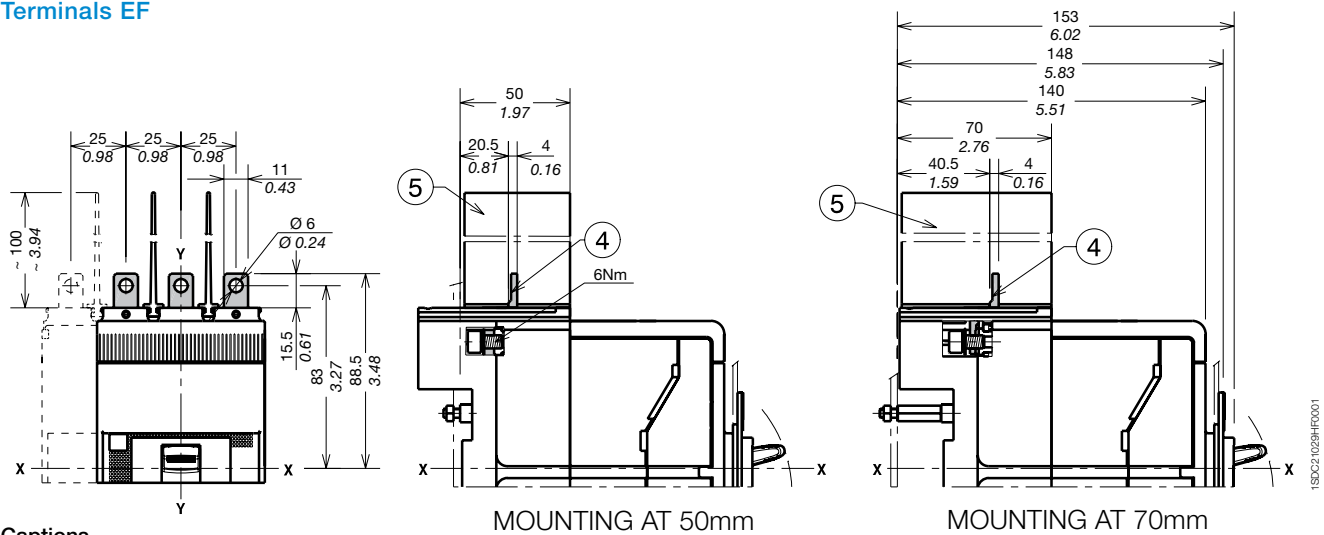

Captions

- ④ Front extended terminals
- ⑤ 100mm insulating barriers between phases (compulsory) provided

Terminals ES

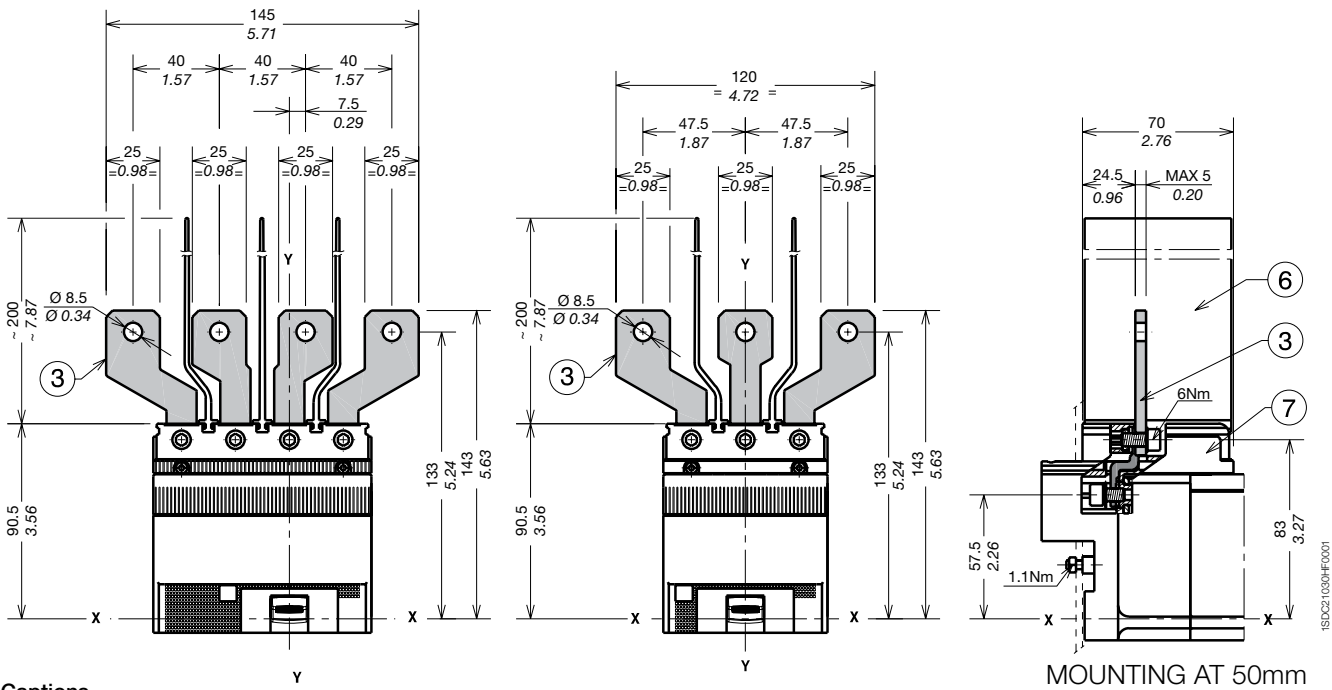

Captions

- ③ Front extended spread terminals
- ⑥ 200mm insulating barriers between phases (compulsory) provided
- ⑦ Adapter (compulsory) not provided

Overall dimensions

Tmax XT1 - Terminals for plug-in circuit breaker

1x1.5...50mm² terminals FCCuAl

Captions

- ① 1x1.5...50mm² front terminal FCCuAl
- ⑤ Adapter (compulsory) optional
- ⑥ 25mm insulating barriers between phases (compulsory) provided

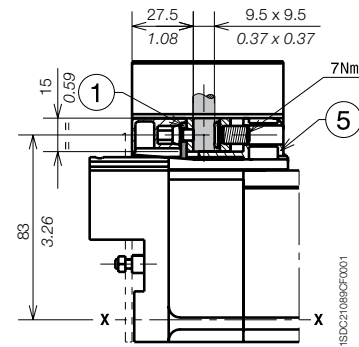
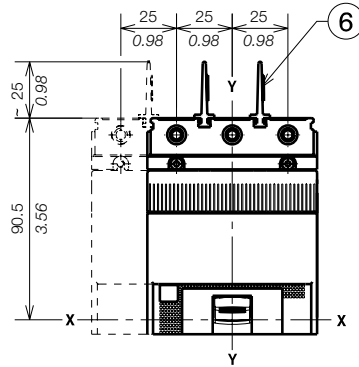

MOUNTING AT 50mm

1x35...95mm² terminals FCCuAl

Captions

- ① External terminal FCCuAl
- ② High terminal covers with degree of protection IP40 (optional) provided

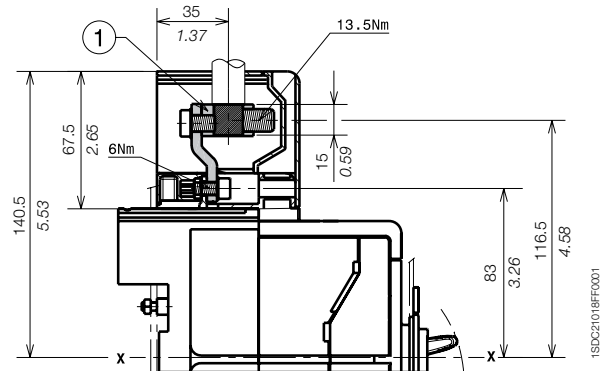
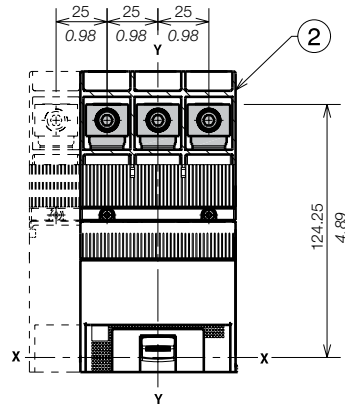

Terminals FCCu

Captions

- ④ Terminals FCCu
- ⑤ Adapter (compulsory) not provided
- ⑥ 25mm insulating barriers between phases (compulsory) provided

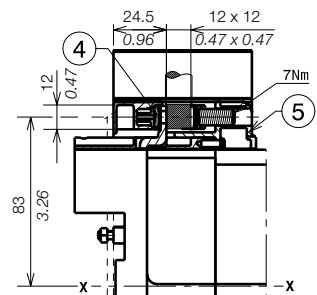
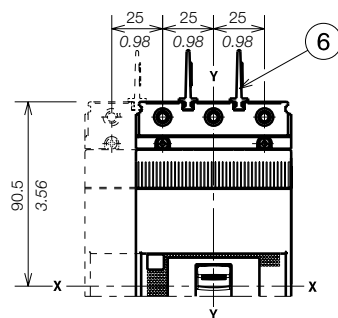

MOUNTING AT 50mm

Terminals MC

Captions

- ② Terminal covers with degree of protection IP40 (optional) provided
- ③ Front terminal for multi-cable connection
- ⑤ Adapter (compulsory) not provided

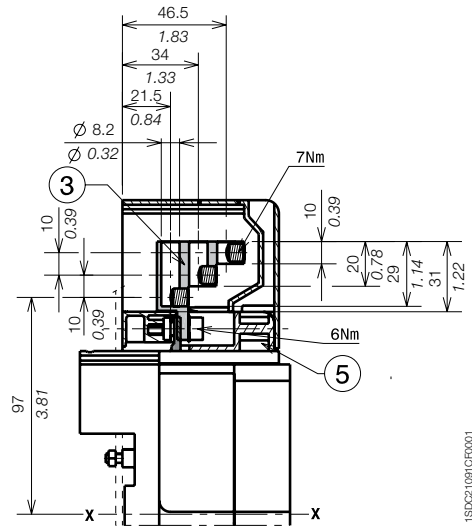
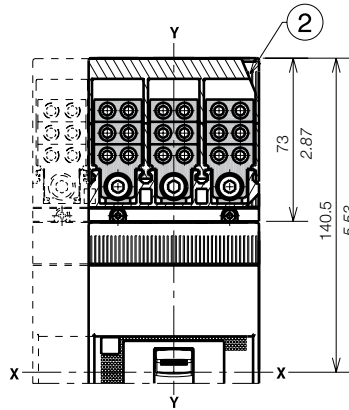

MOUNTING AT 50mm

1SD21091CF0001

Terminals HR/VR

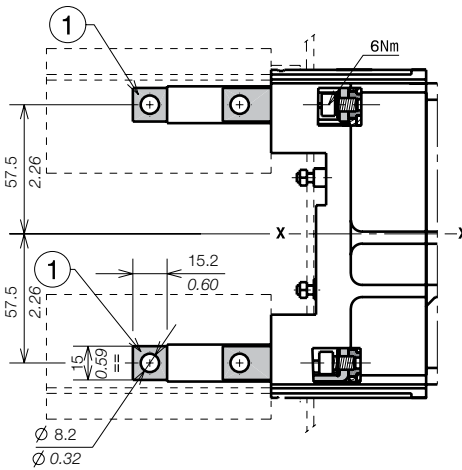
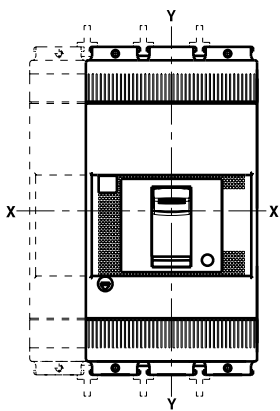

MOUNTING AT 50mm

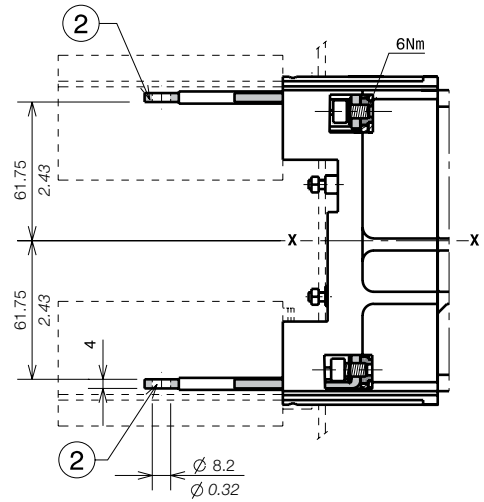

MOUNTING AT 50mm

Captions

- ① Rear vertical terminals
- ② Rear horizontal terminals
- ③ 90mm insulating barriers between phases (compulsory) not provided

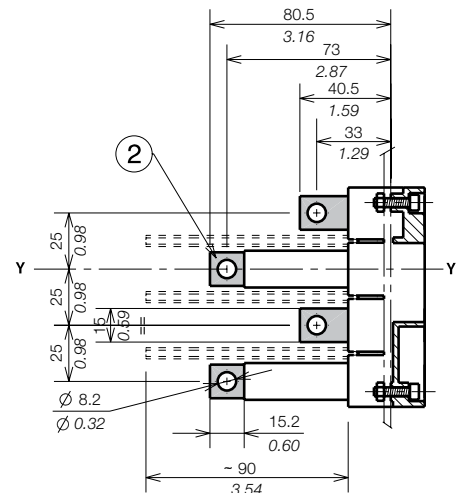
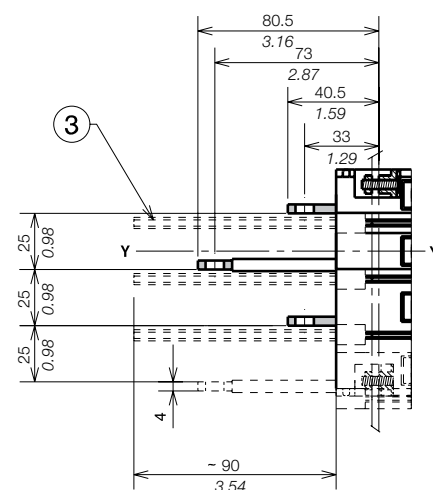

1SD21092CF0001

Overall dimensions

Tmax XT1 - Terminals for plug-in circuit breaker

Terminals HR/VR

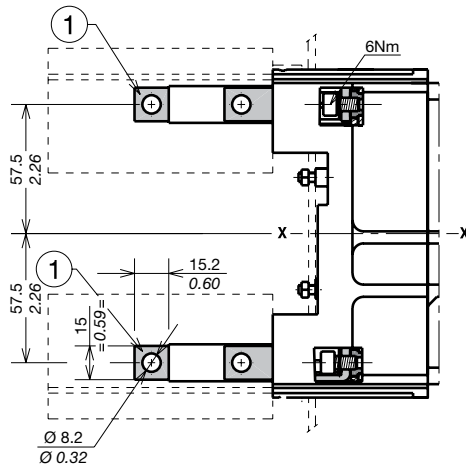
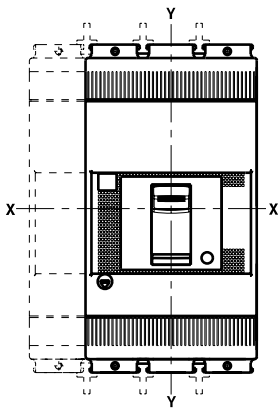

MOUNTING AT 50mm

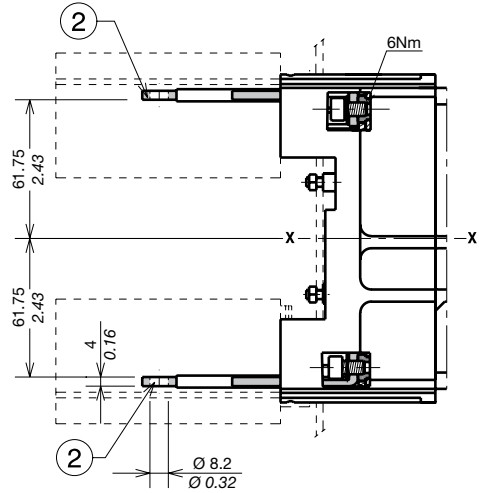

MOUNTING AT 50mm

Captions

- ① Rear vertical terminals
- ② Rear horizontal terminals
- ③ 90mm insulating barriers between phases (compulsory) not provided

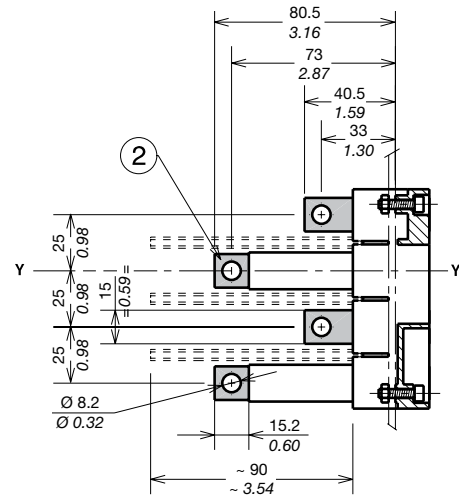
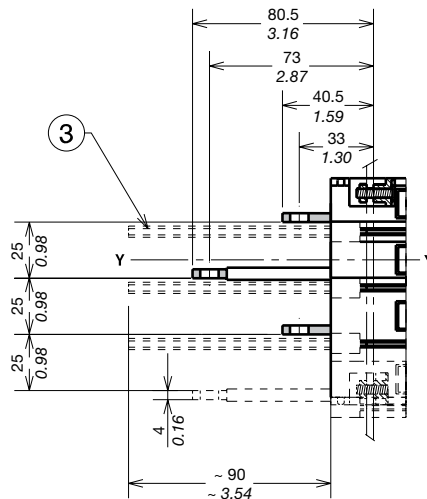

1SD021031HR0001

Overall dimensions

Tmax XT1 - Accessories for plug-in circuit breaker

Direct motor operator (MOD)

Captions

- ① Fixed part
- ② Moving part
- ③ Key lock (not provided)
- ④ Direct motor operator (MOD)
- ⑤ Drilling template of door with MOD without flange
- ⑥ Drilling template of door with MOD with flange
- ⑦ Cable connection

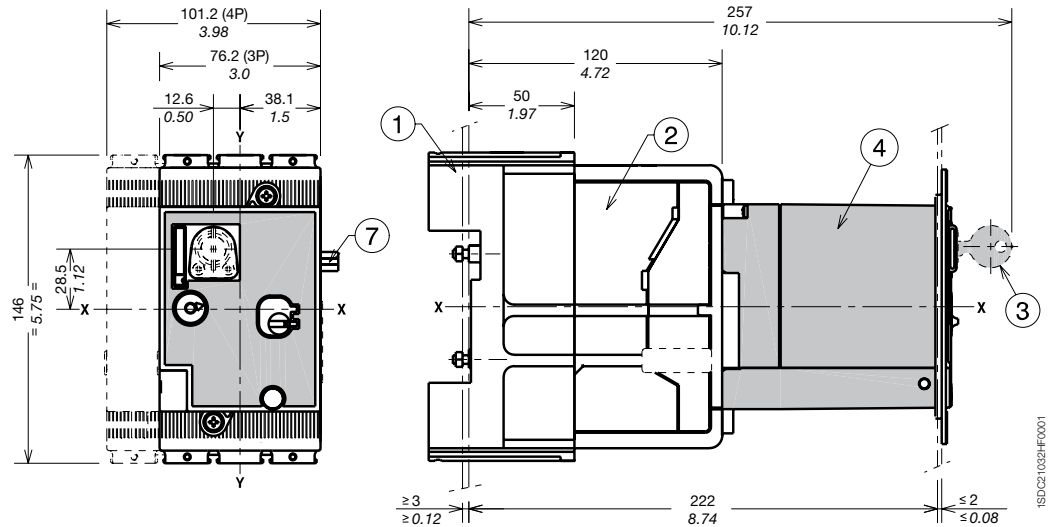

MOUNTING AT 50mm

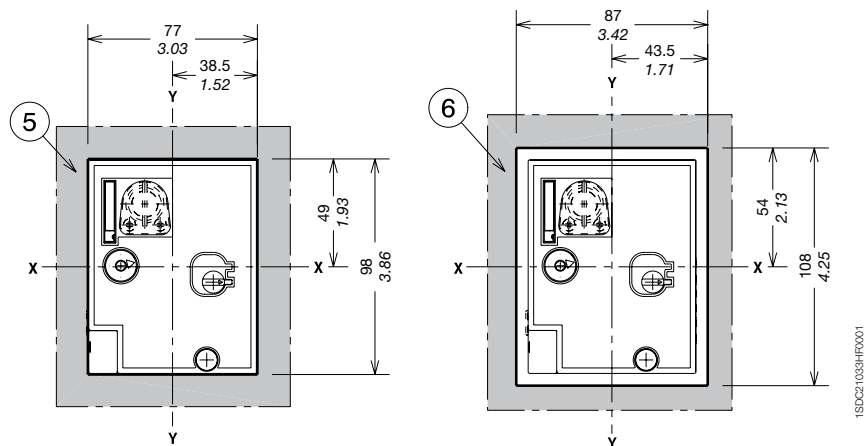

Overall dimensions

Tmax XT2 - Installation for fixed circuit breaker

Fixed circuit breaker mounting on the backplate

Captions

- ① Insulating plate compulsory
- ② Optional wiring ducts
- ③ 25mm insulating barriers between phases (compulsory) provided
- ④ Front carter compulsory for through door of the panel $\leq 25\text{mm}/0,98''$

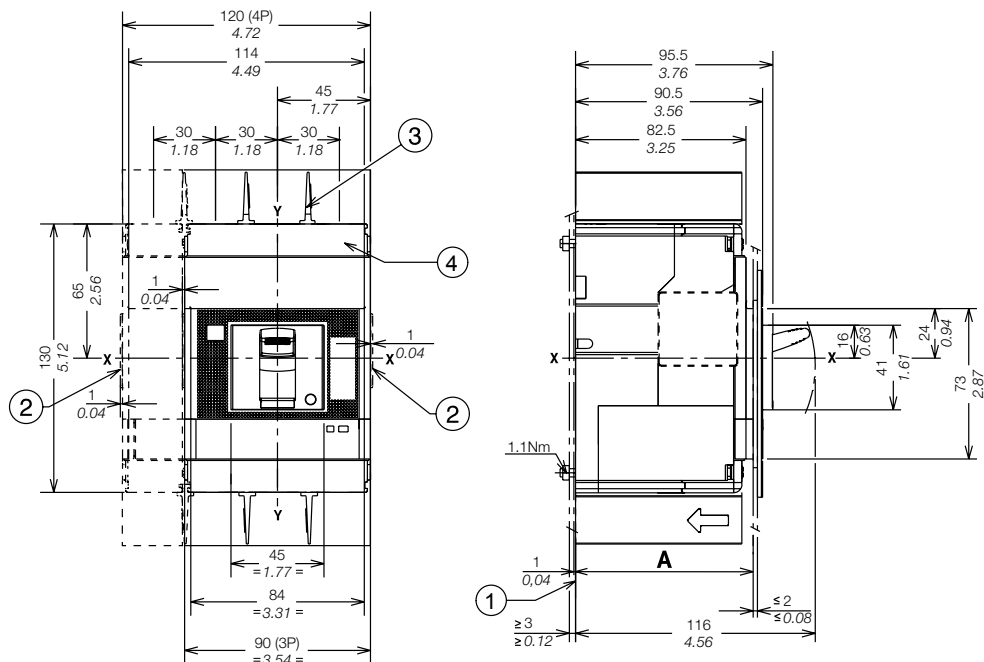

Fixed circuit breaker mounting on DIN EN 50022 rail

Captions

- ① Mounting bracket
- ② Insulating plate compulsory
- ③ 25mm insulating barriers between phases (compulsory) provided

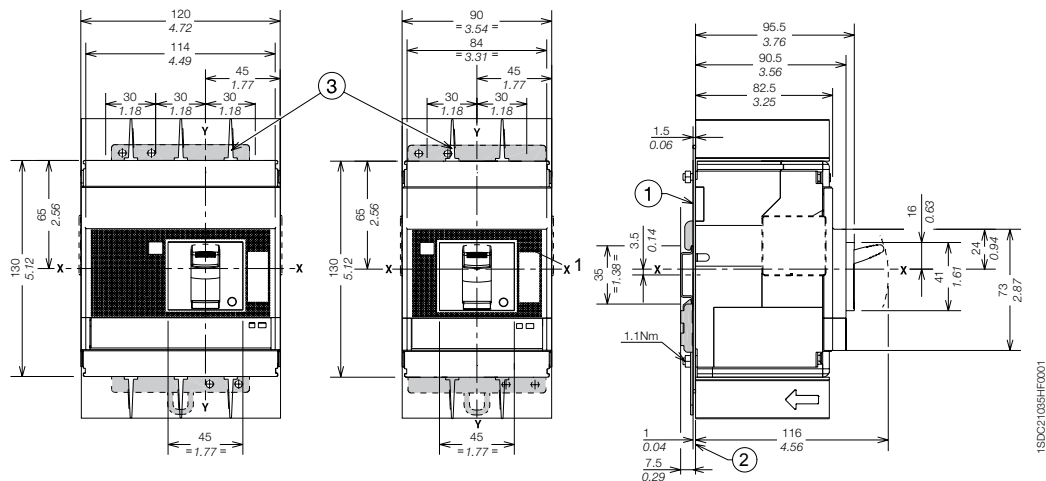

Drilling templates

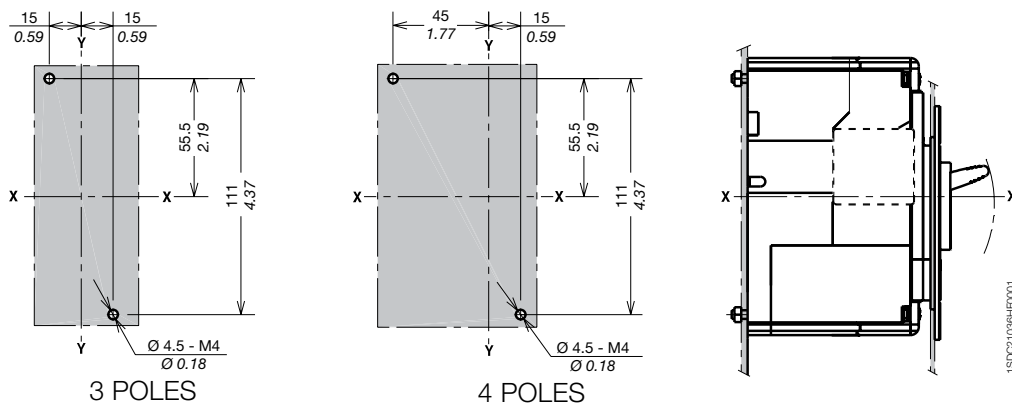

Flanges

Captions

- ① Flange for fixed circuit breaker III
- ② Flange for fixed circuit breaker IV
- ③ Flange for fixed circuit breaker III-IV with MOE and FLD
- ④ Flange for circuit breaker III-IV with direct rotary handle RHD
- ⑤ Optional flange

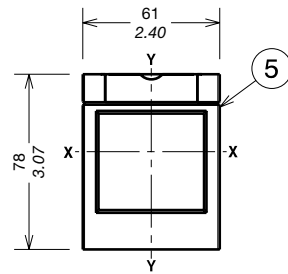
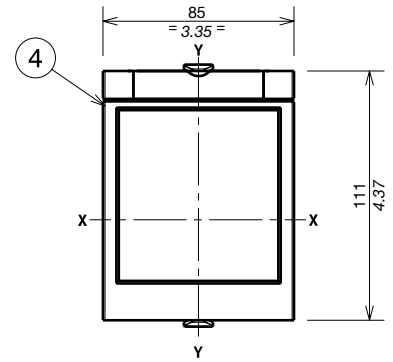
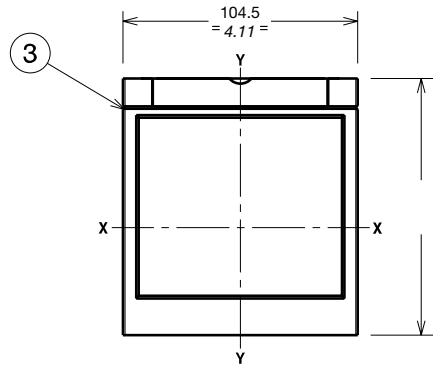
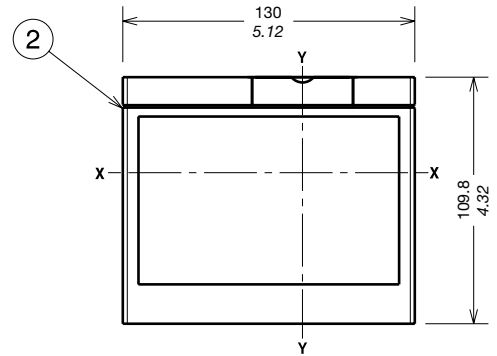
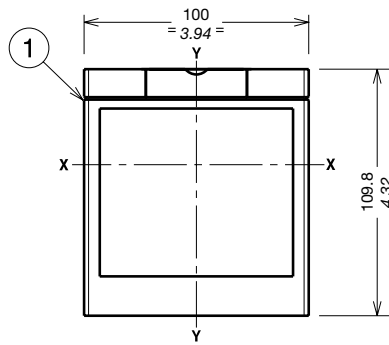

1SDC21037HF0001

Overall dimensions

Tmax XT2 - Installation for fixed circuit breaker

Drilling templates for compartment door

With standard flange

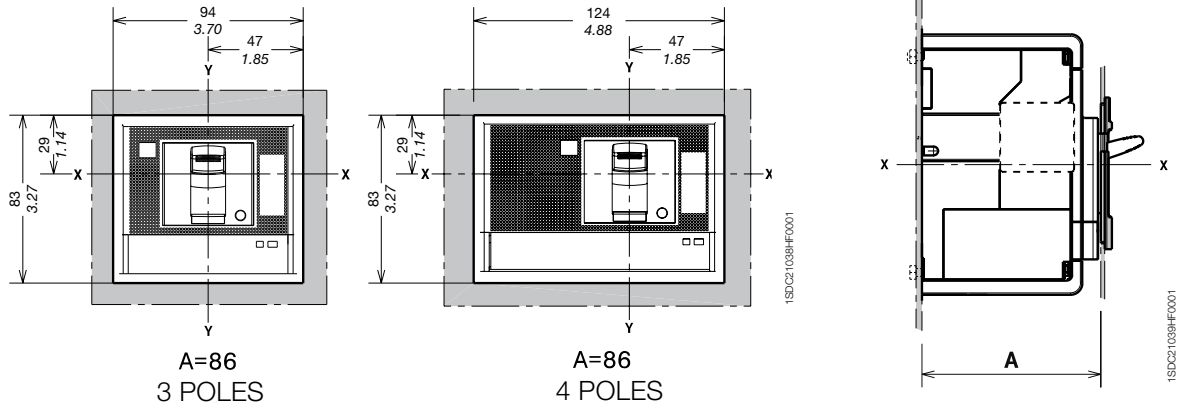

Without flange

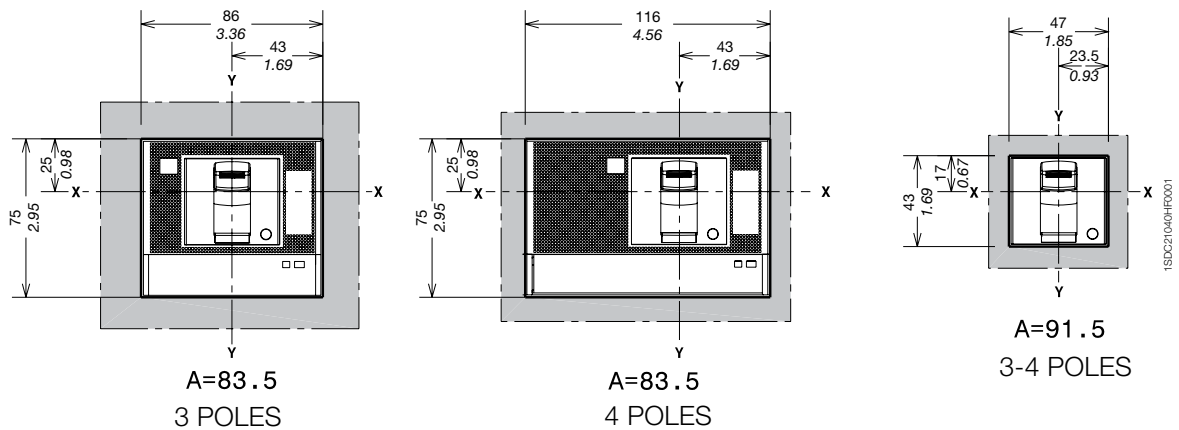

With optional flange

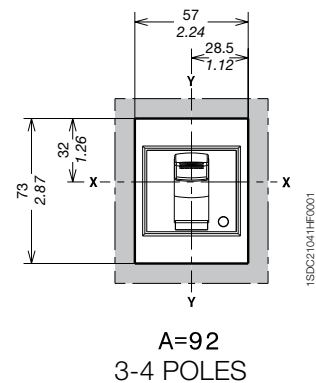

Caption

① Optional flange

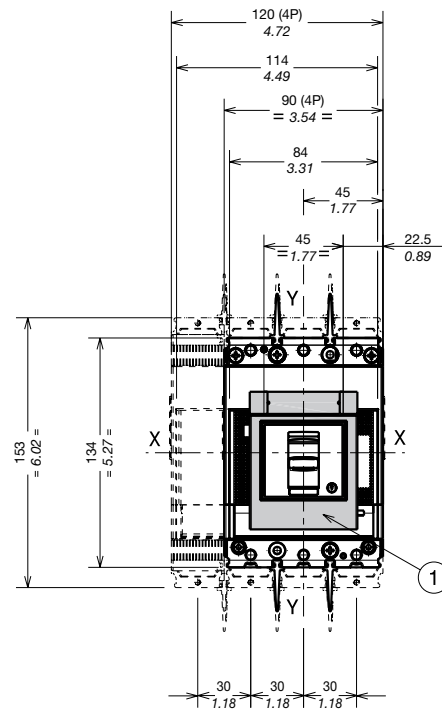

Execution	A	B	C
With optional flange fixed	92		3-4 poles
plug-in, mounting at 50mm		142	3-4 poles
plug-in, mounting at 70mm		162	3-4 poles

Overall dimensions

Tmax XT2 - Terminals for fixed circuit breaker

Terminals F

Captions

- ① 25mm insulating barriers between phases (compulsory) not provided
- ② Front terminals for busbar connection

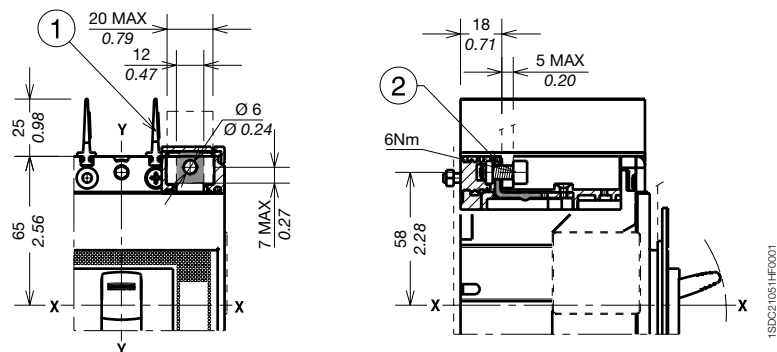

Terminals EF

Captions

- ③ Front extended terminals
- ④ Terminal covers with degree of protection IP40 (optional) not provided
- ⑤ 100mm insulating barriers between phases (compulsory) provided
- ⑥ Insulated plate (compulsory) provided for XT2 Ue>440V
- ⑦ Drilling template for 3p circuit breaker Ue>440V (compulsory)
- ⑧ Drilling template for 4p circuit breaker Ue>440V (compulsory)

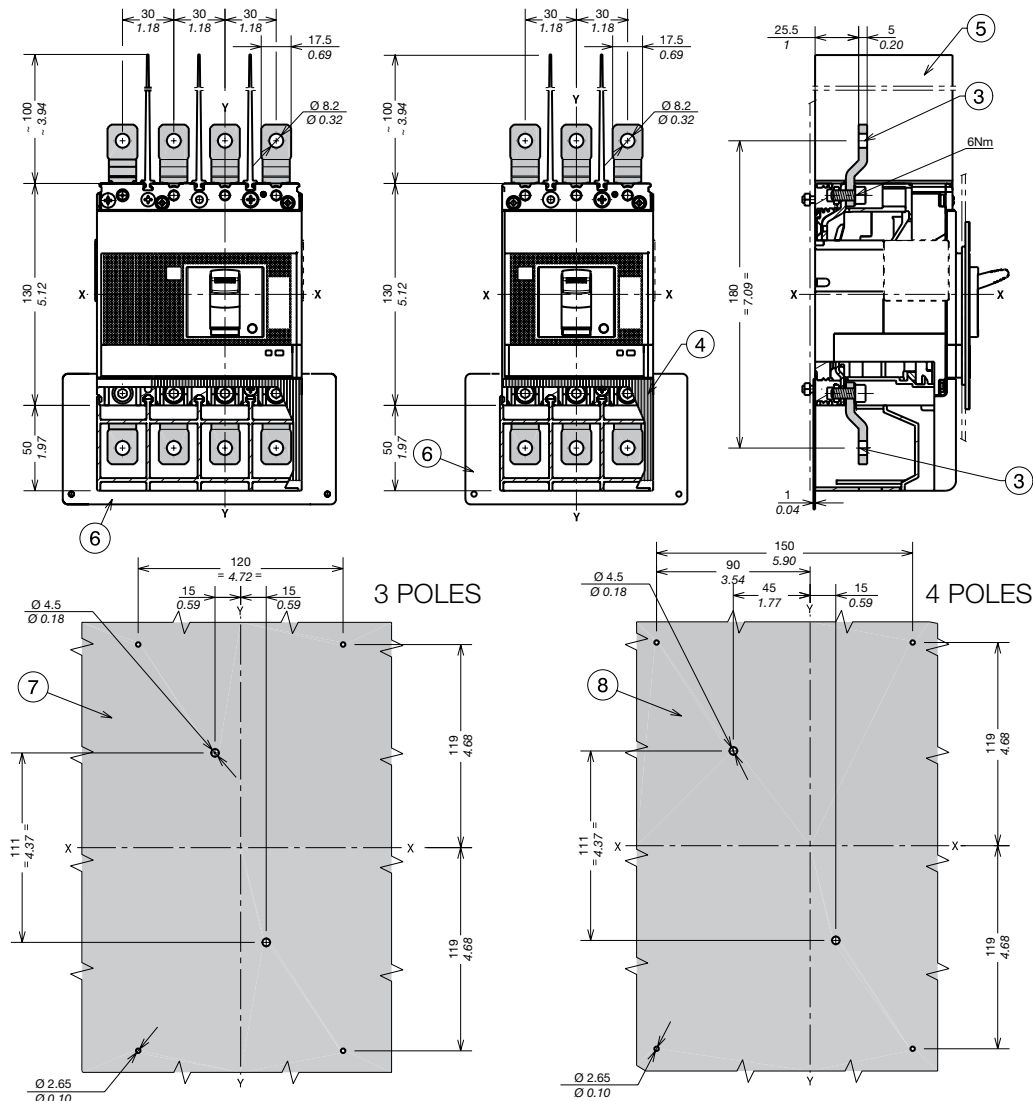

Overall dimensions

Tmax XT2 - Terminals for fixed circuit breaker

Terminals ES

Captions

- ① Drilling template for 3p circuit breaker Ue>440V (compulsory)
- ② Drilling template for 4p circuit breaker Ue>440V (compulsory)
- ③ Front extended spread terminals
- ④ 200mm insulating barriers between phases (compulsory) provided for Ue>440V
- ⑤ Insulated plate (compulsory) provided for XT2 Ue>440V

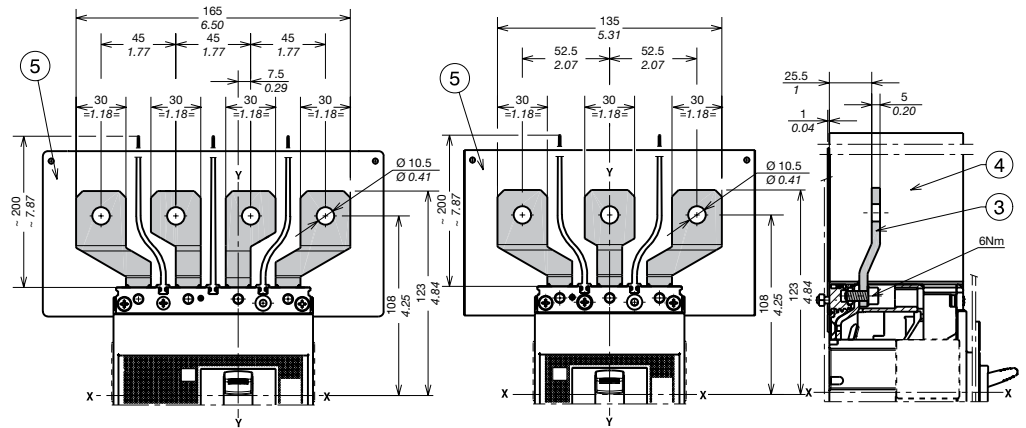

3 POLES

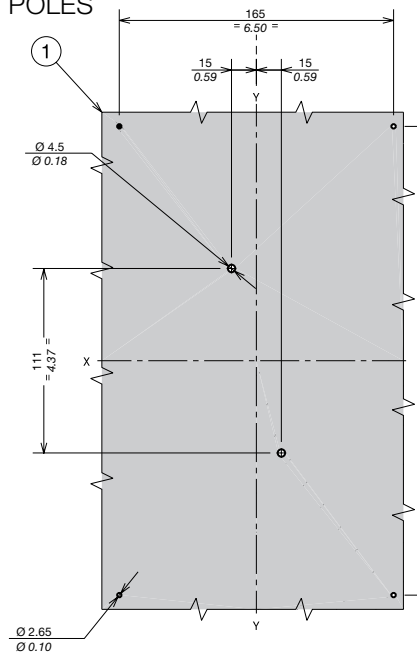

4 POLES

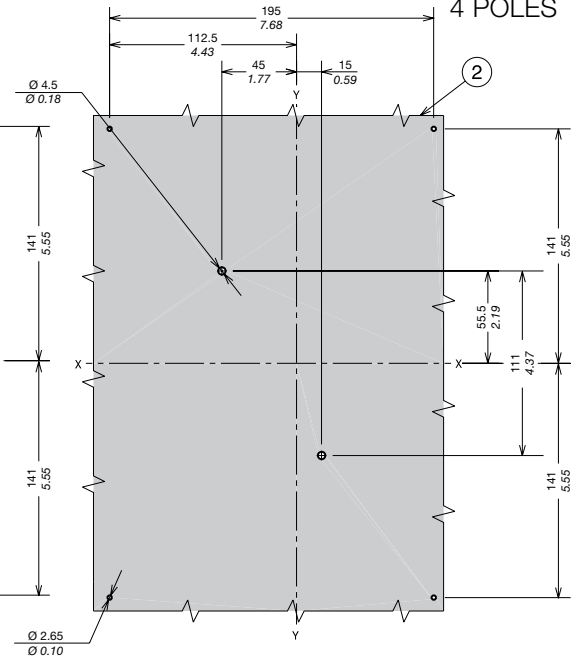

1SD2C1044HF0001

Terminals FCCu

Captions

- ③ 25mm insulating barriers between phases (compulsory) provided as standard with the circuit breaker
- ⑥ Terminals FCCu

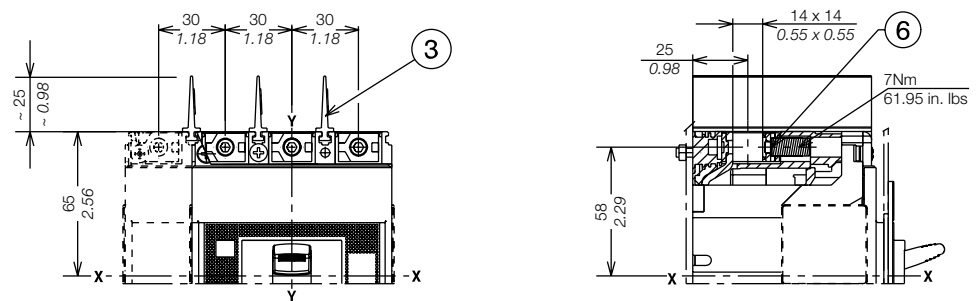

1SDC21048HF001

Terminals MC

Caption

- ⑥ Multi-cable terminals

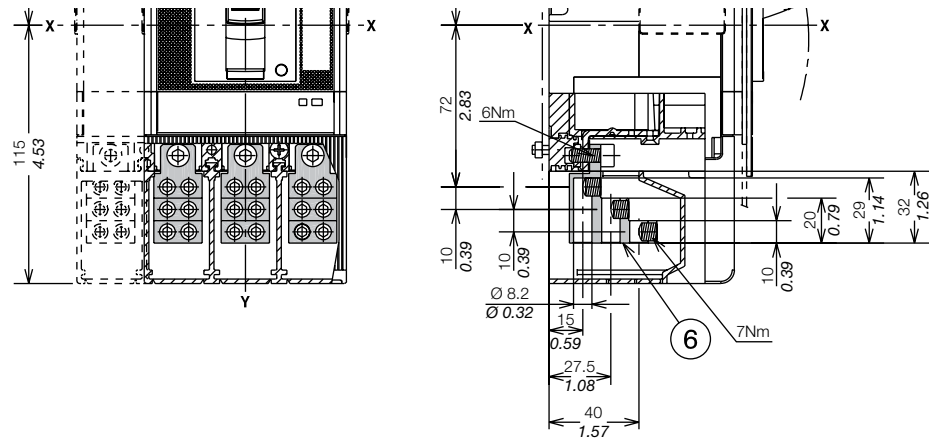

1SDC21049HF001

Terminals R

Captions

- ① Rear adjustable terminals
- ② Bottom terminal covers with degree of protection IP30 (optional) provided
- ③ Drilling template for mounting circuit breaker III sheet
- ④ Drilling template for mounting circuit breaker IV sheet

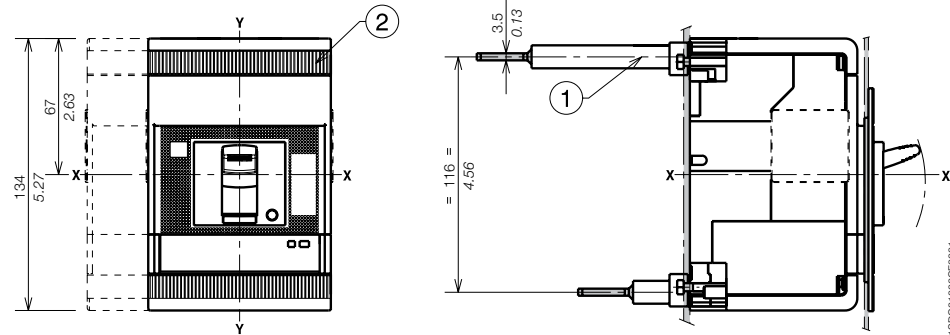

1SDC21036CF001

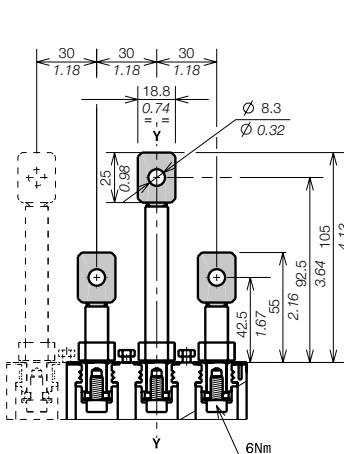

1SDC21002CF001

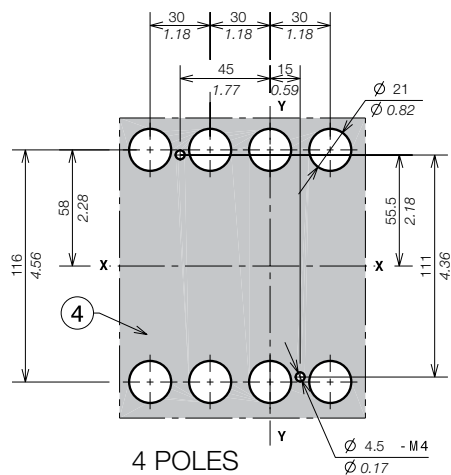
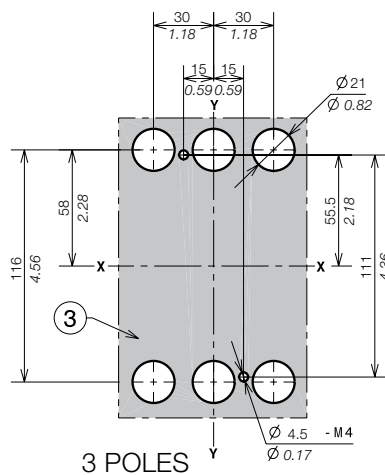

1SDC21007CF001

Overall dimensions

Tmax XT2 - Accessories for fixed circuit breaker

Rotary handle operating mechanism on circuit breaker (RHD)

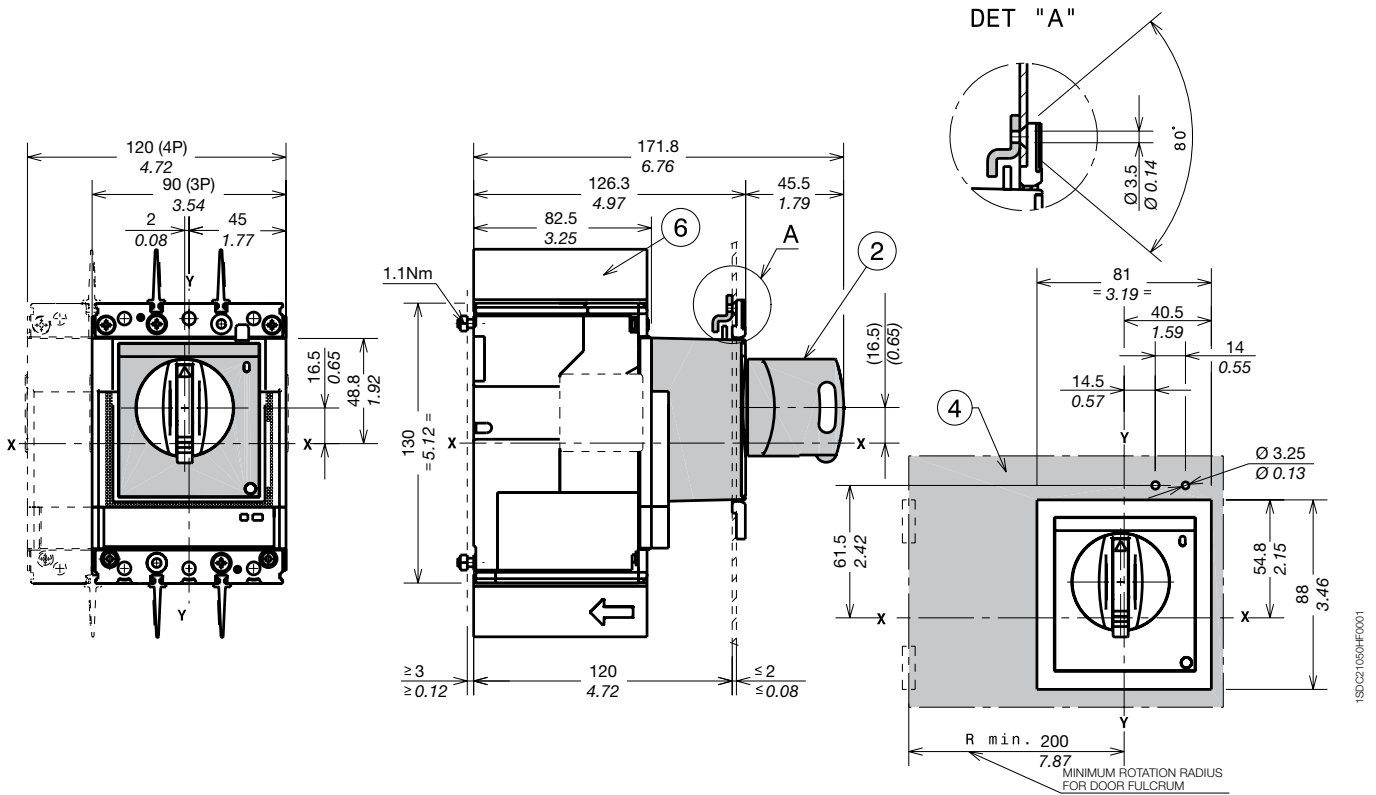

Captions

- ② Rotary handle operating mechanism on circuit breaker
- ④ Drilling template of door with direct rotary handle
- ⑥ 25mm insulating barriers between phases provided with circuit breaker

Rotary handle operating mechanism on the compartment door (RHE)

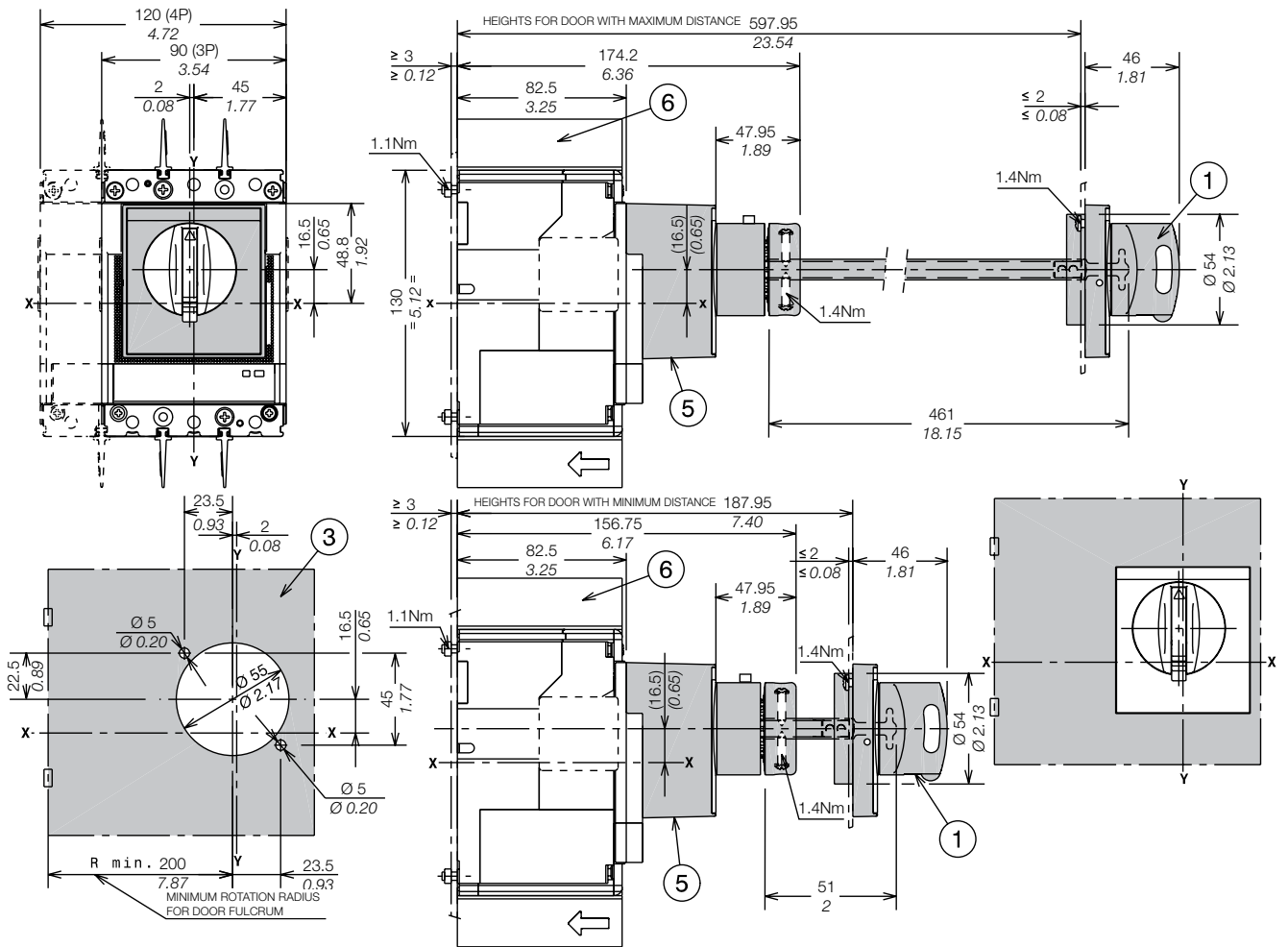

Captions

- ① Extended rotary handle operating mechanism
- ③ Door drilling template with extended rotary handle
- ⑤ Transmission unit
- ⑥ 25mm insulating barriers between phases provided with circuit breaker

1SDC21052AF0001

Overall dimensions

Tmax XT2 - Accessories for fixed circuit breaker

Stored energy motor operator (MOE)

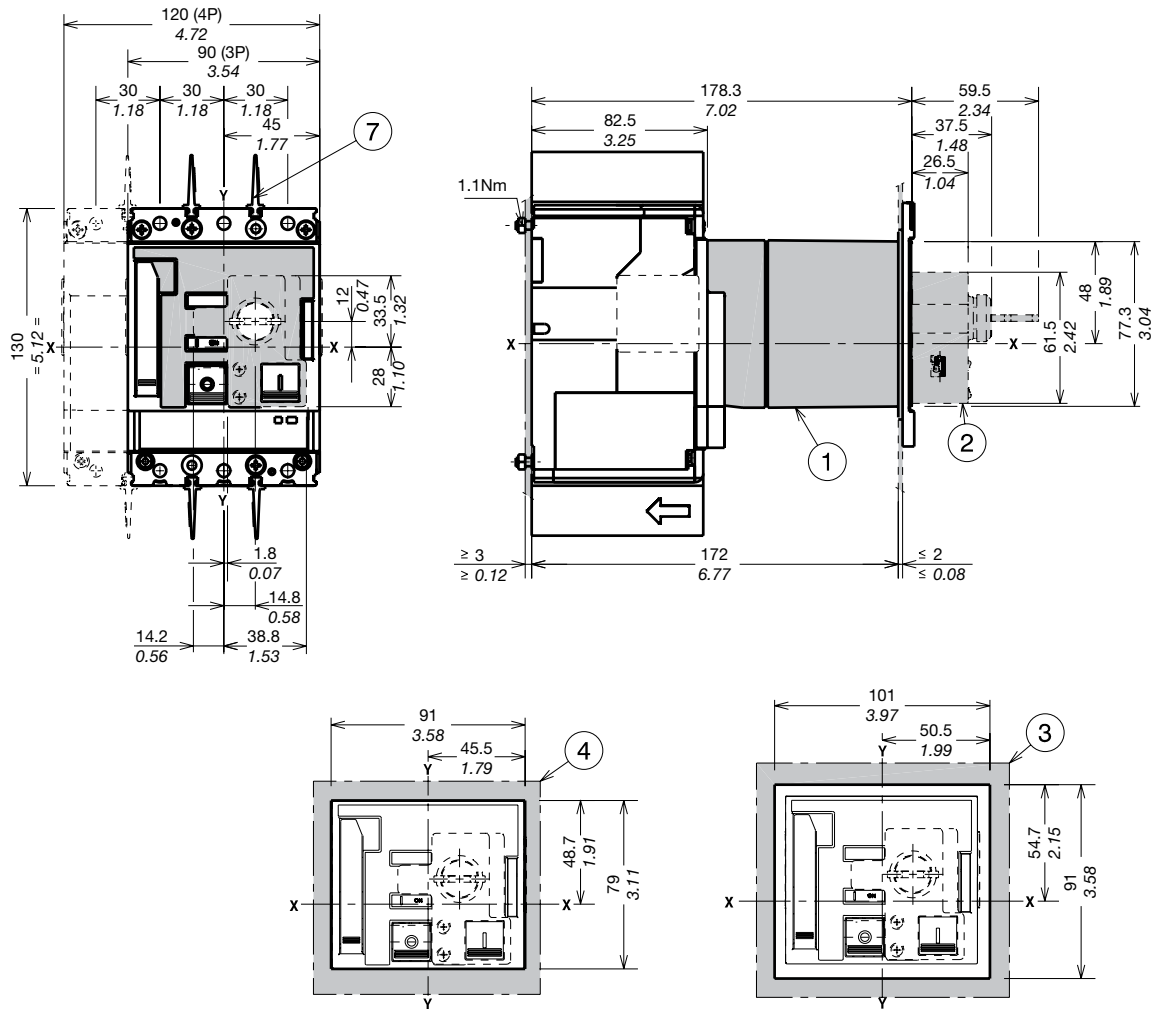

3 POLES

4 POLES

Captions

- ① Stored energy motor operator (MOE)
- ② Key lock (not provided)
- ③ Drilling template of door with MOE with flange
- ④ Door drilling template with MOE without flange
- ⑤ Drilling template for mounting 3p circuit breaker on the backplate
- ⑥ Drilling template for mounting 4p circuit breaker on the backplate
- ⑦ 25mm insulating barriers between phases provided with circuit breaker

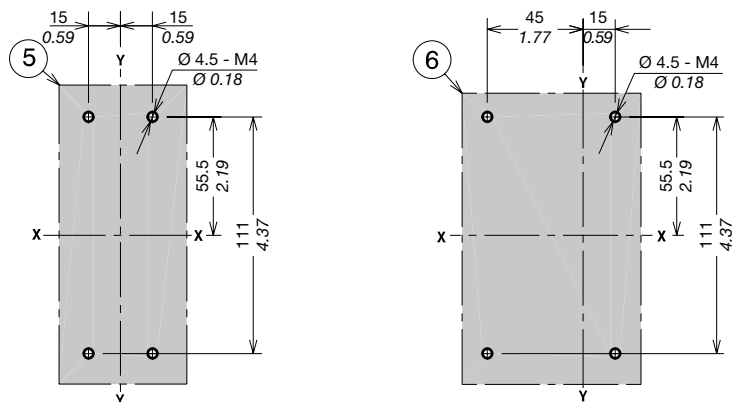

ISDC21063HF0001

Front for lever operating mechanism (FLD)

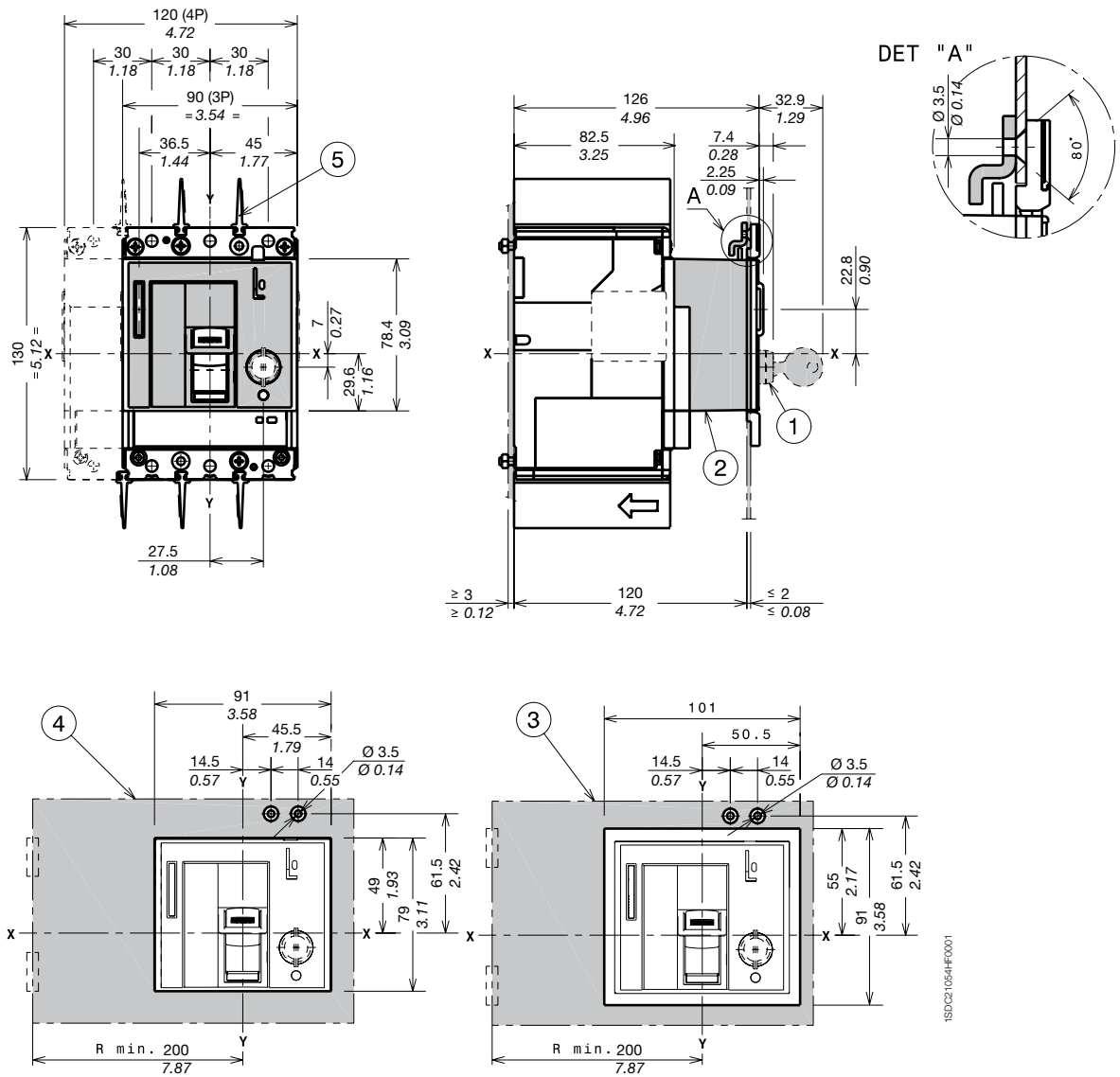

Captions

- ① Key lock optional
- ② Front for lever operating mechanism (FLD)
- ③ Drilling template of door with FLD with flange
- ④ Drilling template of door with FLD without flange
- ⑤ 25mm insulating barriers between phases provided with circuit breaker

Residual current RC Sel

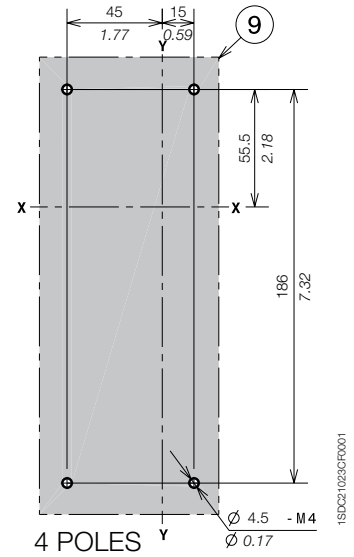
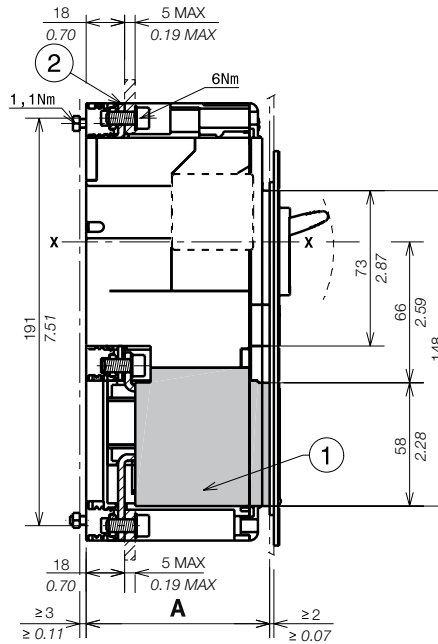
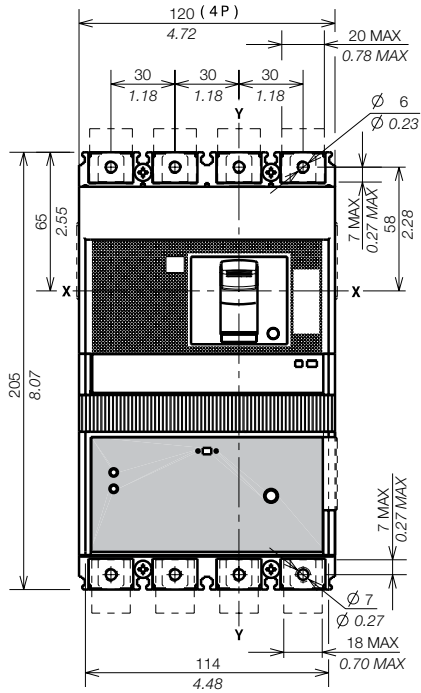

Captions

- ① Residual current
- ② Front terminals
- ⑦ Drilling template of door with direct rotary handle and mounting with flange
- ⑧ Drilling template of door with direct rotary handle and mounting without flange
- ⑨ Drilling template for mounting circuit breaker on sheet

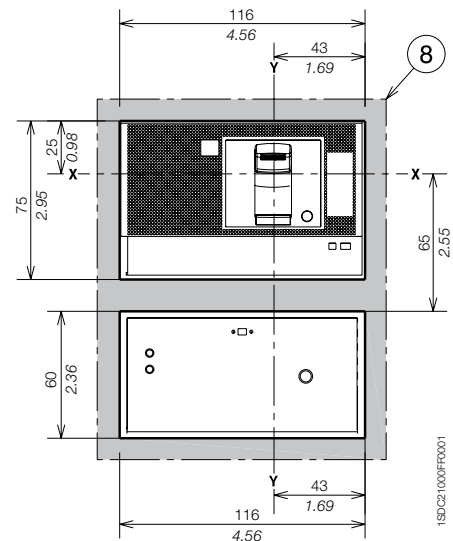
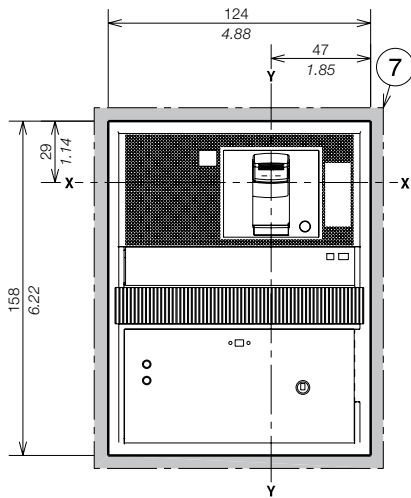

		A
With standard flange	IV	86
Without flange	IV	83.5

Overall dimensions

Tmax XT2 - Installation for plug-in circuit breaker

Plug-in circuit breaker mounting on sheet

Captions

- ① Fixed part
- ② Moving part

Mounting at 50mm		A
With standard flange	III - IV	136
Without flange	III - IV	133.5
	III - IV	141.5

Mounting at 70mm for extended front terminals		A
With standard flange	III - IV	156
Without flange	III - IV	153.5
	III - IV	161.5

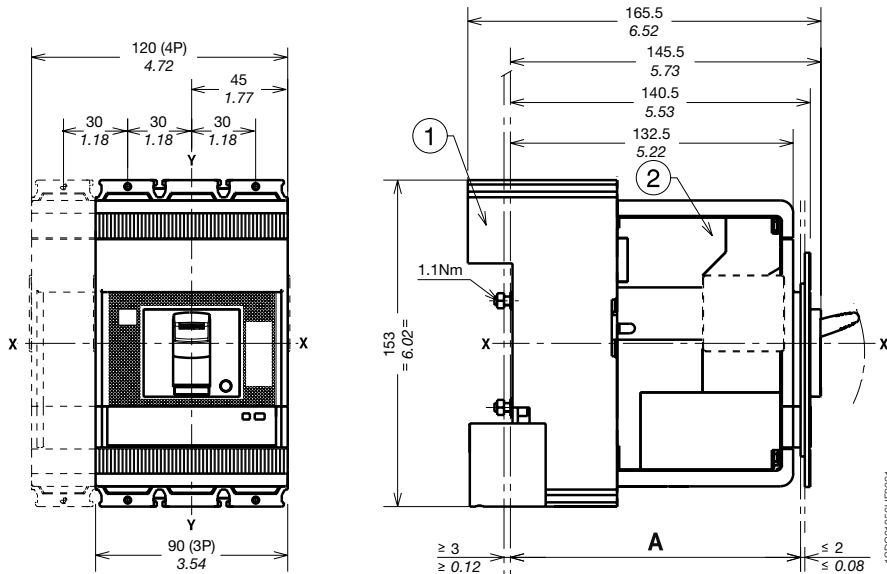

Drilling templates for the backplate

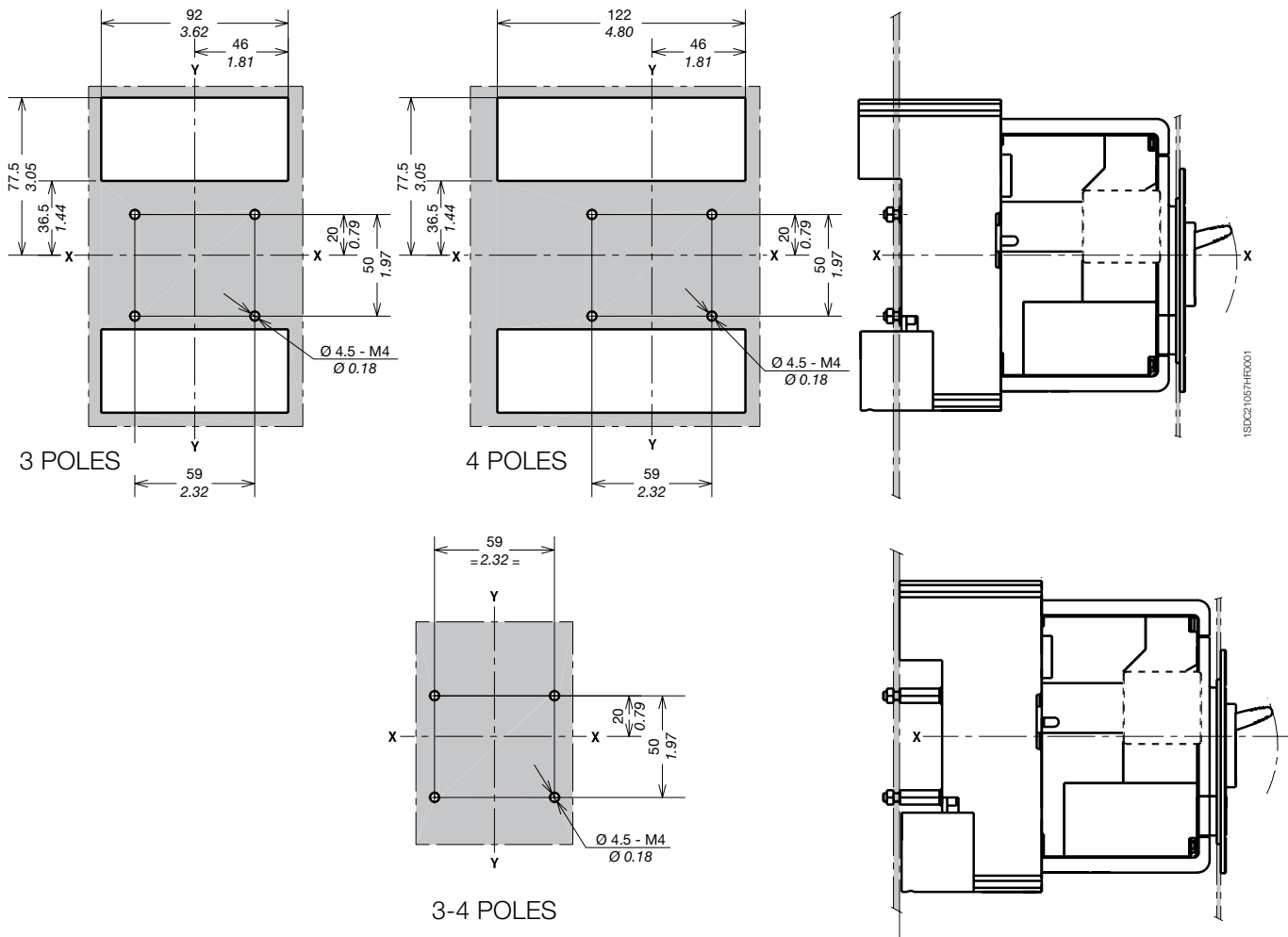

Flanges

Captions

- ① Flange for withdrawable circuit breaker III
- ② Flange for circuit breaker IV
- ③ Flange for plug-in circuit breaker III-IV with MOE and FLD
- ④ Flange for circuit breaker III-IV with direct rotary handle (RHD)
- ⑤ Optional flange

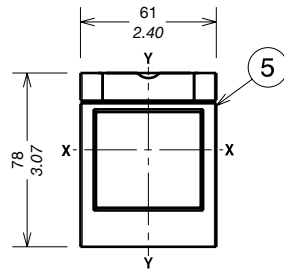
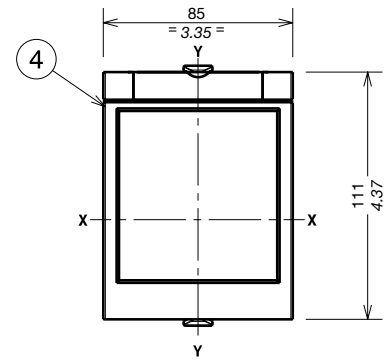
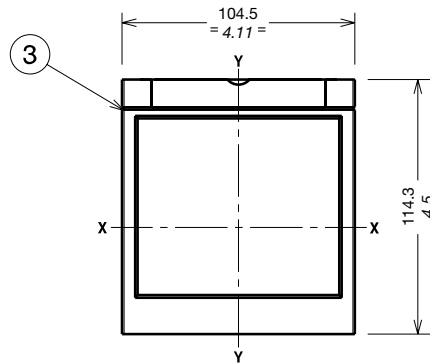
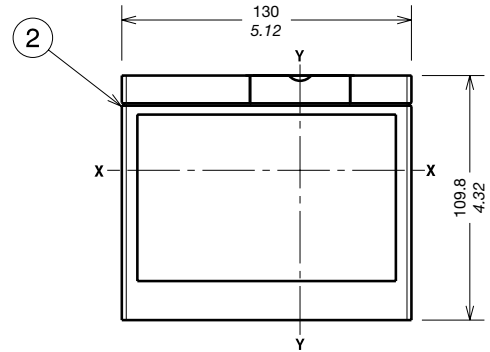
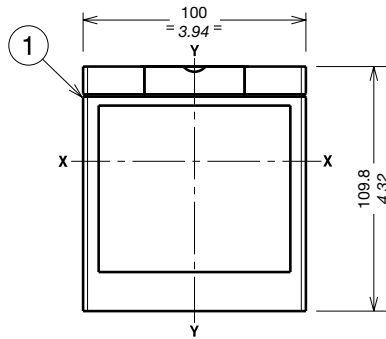

Overall dimensions

Tmax XT2 - Terminals for plug-in circuit breaker

Drilling templates for compartment door

With standard flange

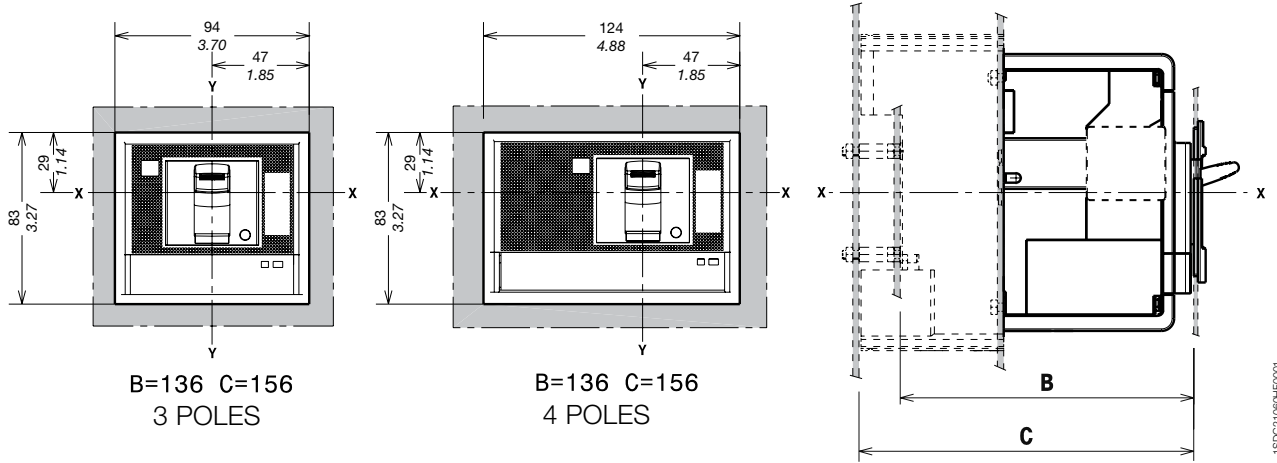

Without flange

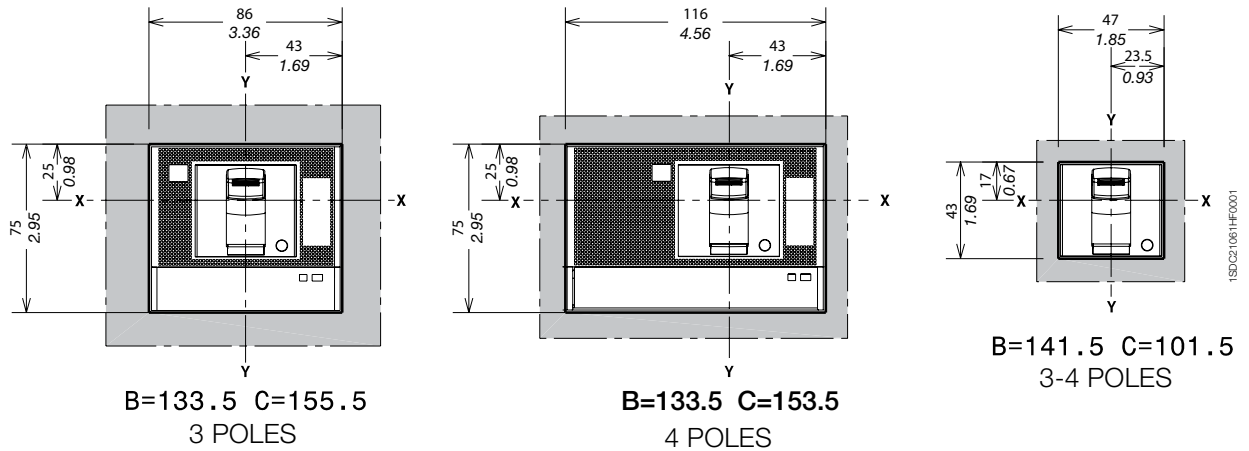

With optional flange

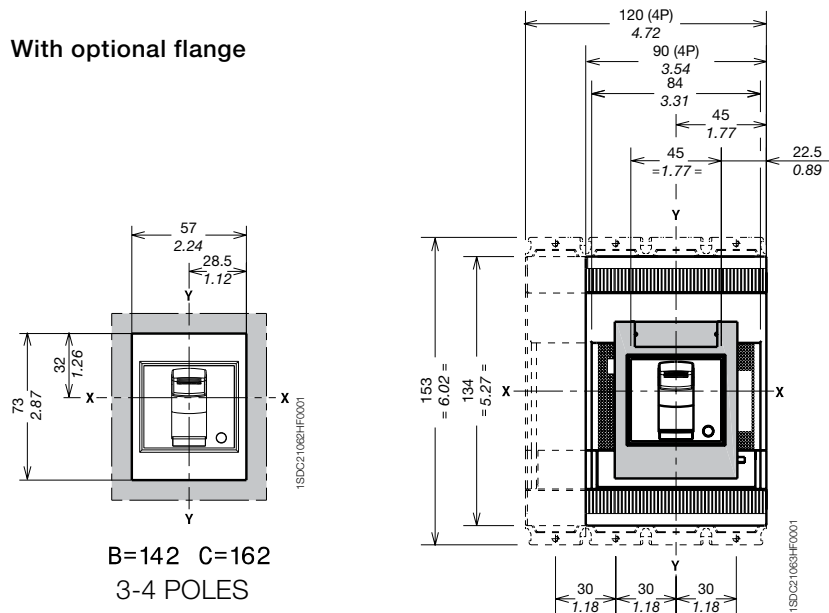

Terminals EF

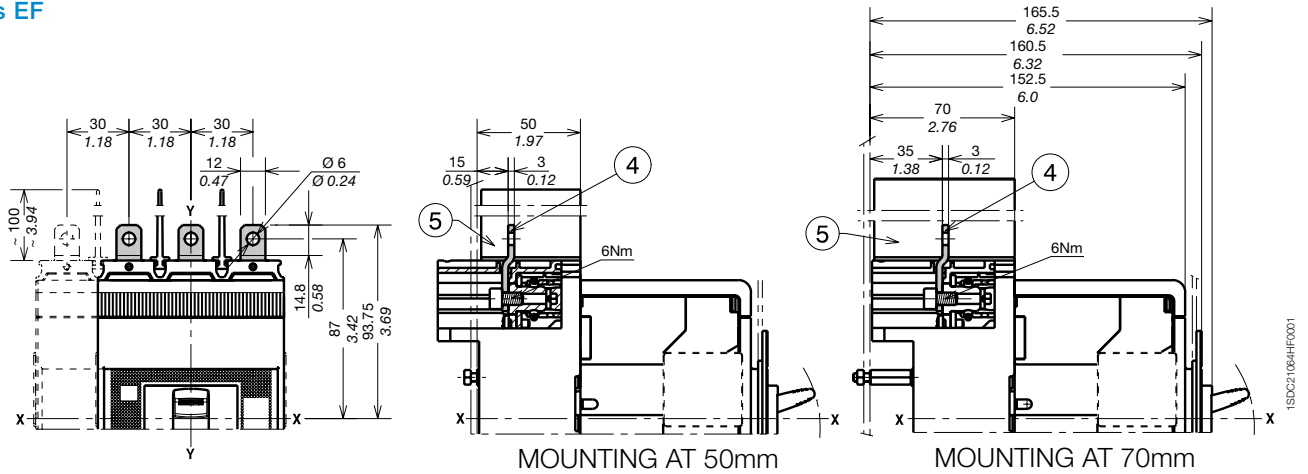

Captions

- ④ Front extended terminals
- ⑤ 100mm insulating barriers between phases (compulsory) provided

Terminals ES

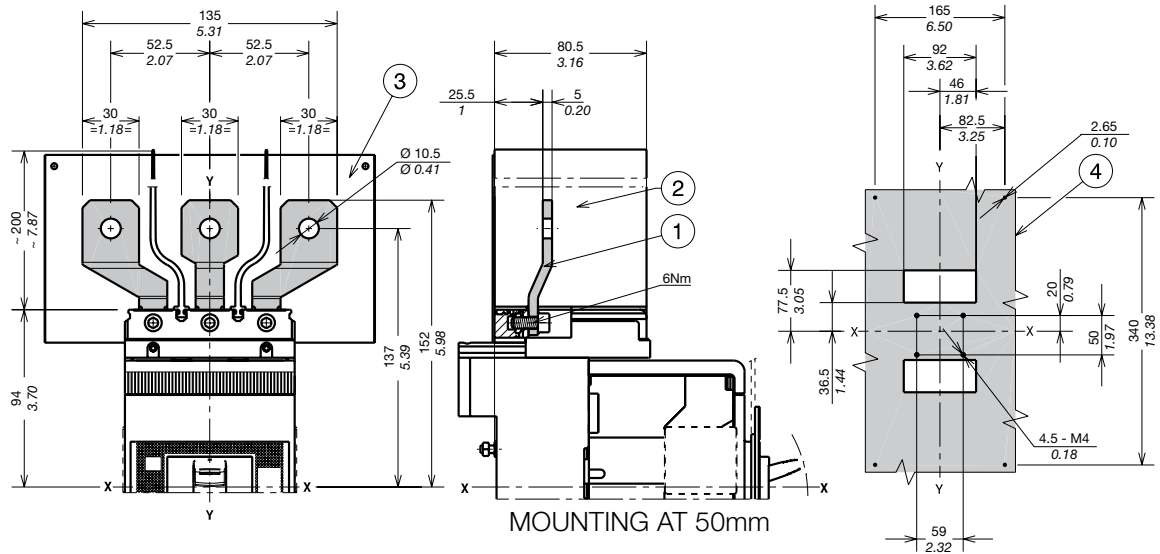

Captions

- ① Front extended spread terminals
- ② 200mm insulating barriers between phases (compulsory) provided
- ③ Insulated plate (compulsory) provided
- ④ Drilling template for 3p circuit breaker $U_e > 440V$ (compulsory)
- ⑤ Drilling template for 4p circuit breaker $U_e > 440V$ (compulsory)

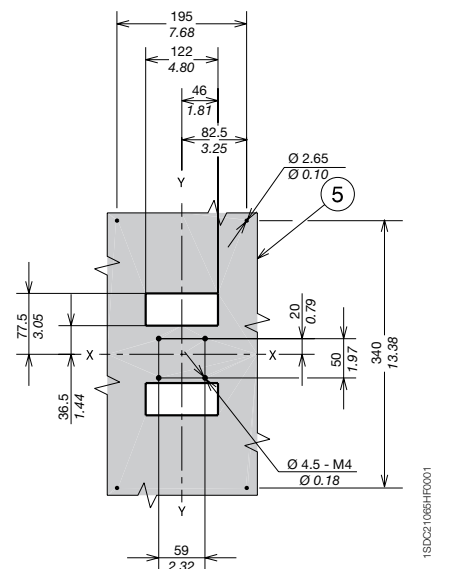

Overall dimensions

Tmax XT2 - Terminals for plug-in circuit breaker

Terminals FCCu

Captions

- ③ Terminals FCCu
- ④ Adapter (compulsory) not provided

Note: 25mm insulating barriers between phases (compulsory) provided as standard with the circuit breaker

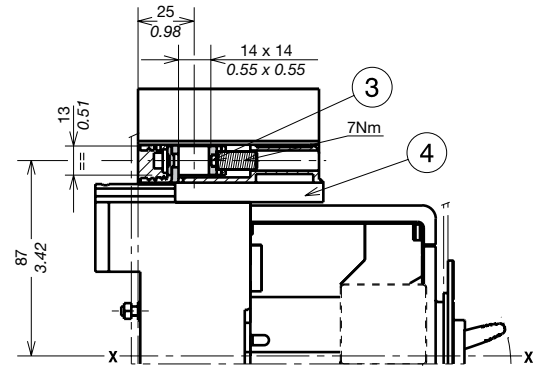
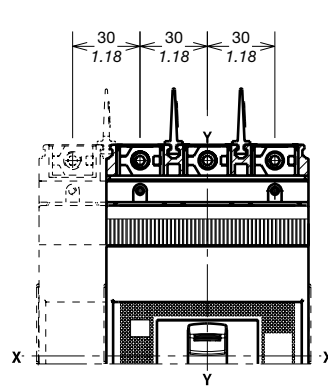

MOUNTING AT 50mm

1SD2C21068HF0001

Terminals MC

Captions

- ③ High terminal covers with degree of protection IP40 (optional) provided
- ④ Multi-cable terminals
- ⑥ Adapter (compulsory) not provided

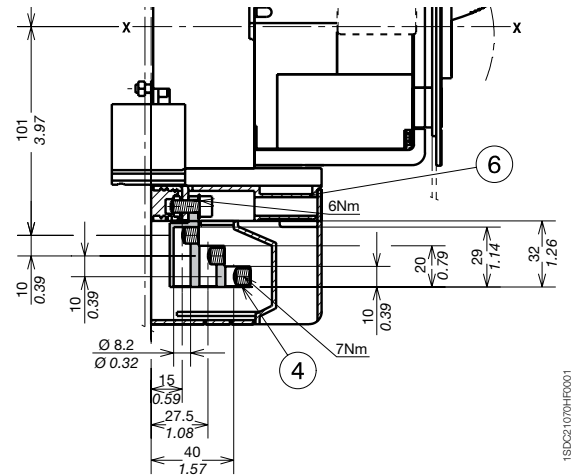
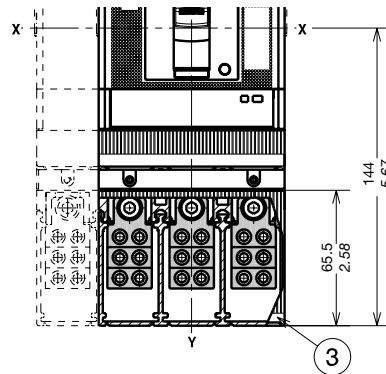

MOUNTING AT 50mm

1SD2C21070HF0001

Terminals HR/VR

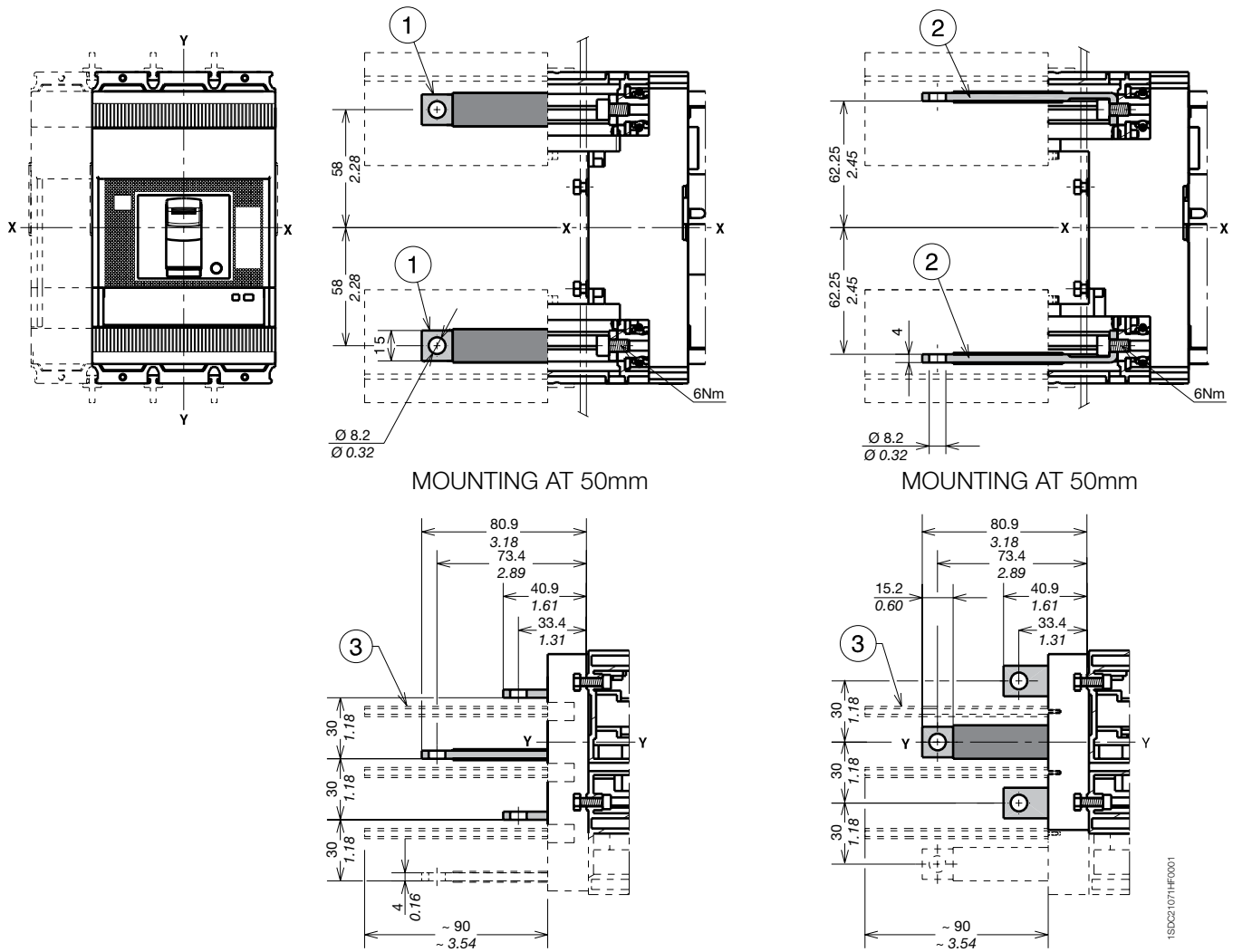

MOUNTING AT 50mm

MOUNTING AT 50mm

Captions

- ① Rear vertical terminals
- ② Rear horizontal terminals
- ③ 90mm insulating barriers between phases (compulsory) not provided

Overall dimensions

Tmax XT2 - Accessories for plug-in circuit breaker

Stored energy motor operator (MOE)

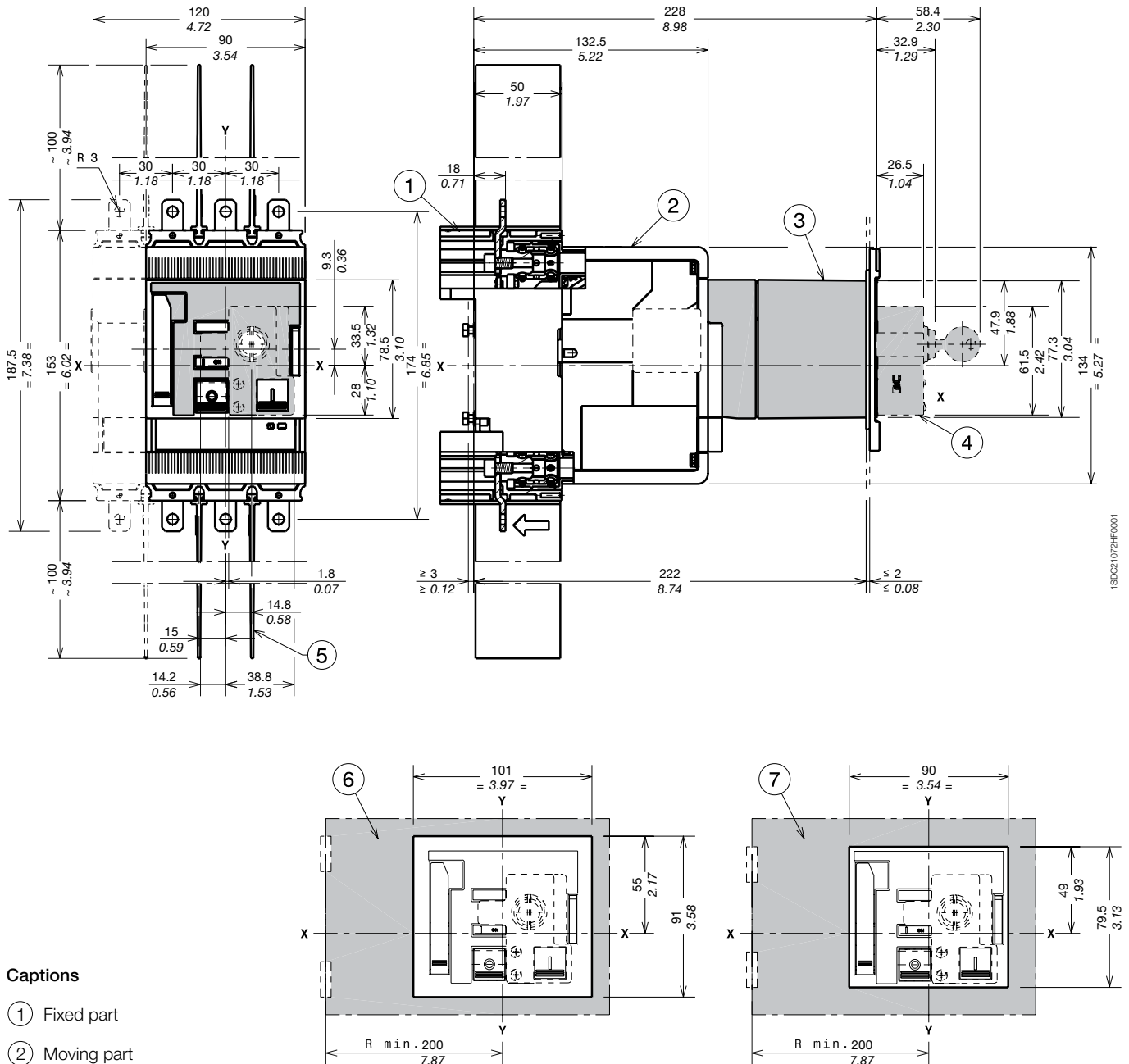

Captions

- ① Fixed part
- ② Moving part
- ③ MOE
- ④ Key lock (not provided)
- ⑤ 100mm insulating barriers between phases (compulsory) provided
- ⑥ Drilling template of door with direct rotary handle with flange
- ⑦ Drilling template of door with direct rotary handle without flange

Front for lever operating mechanism (FLD)

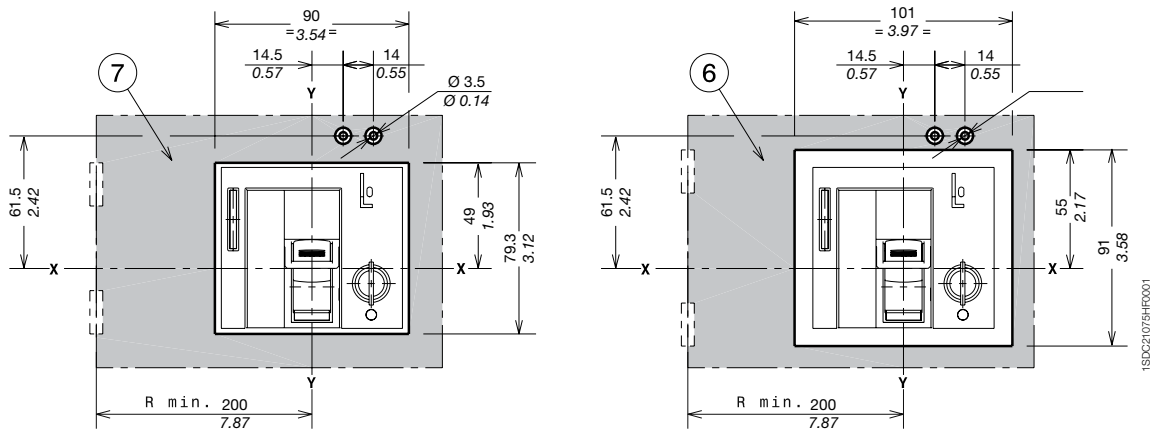
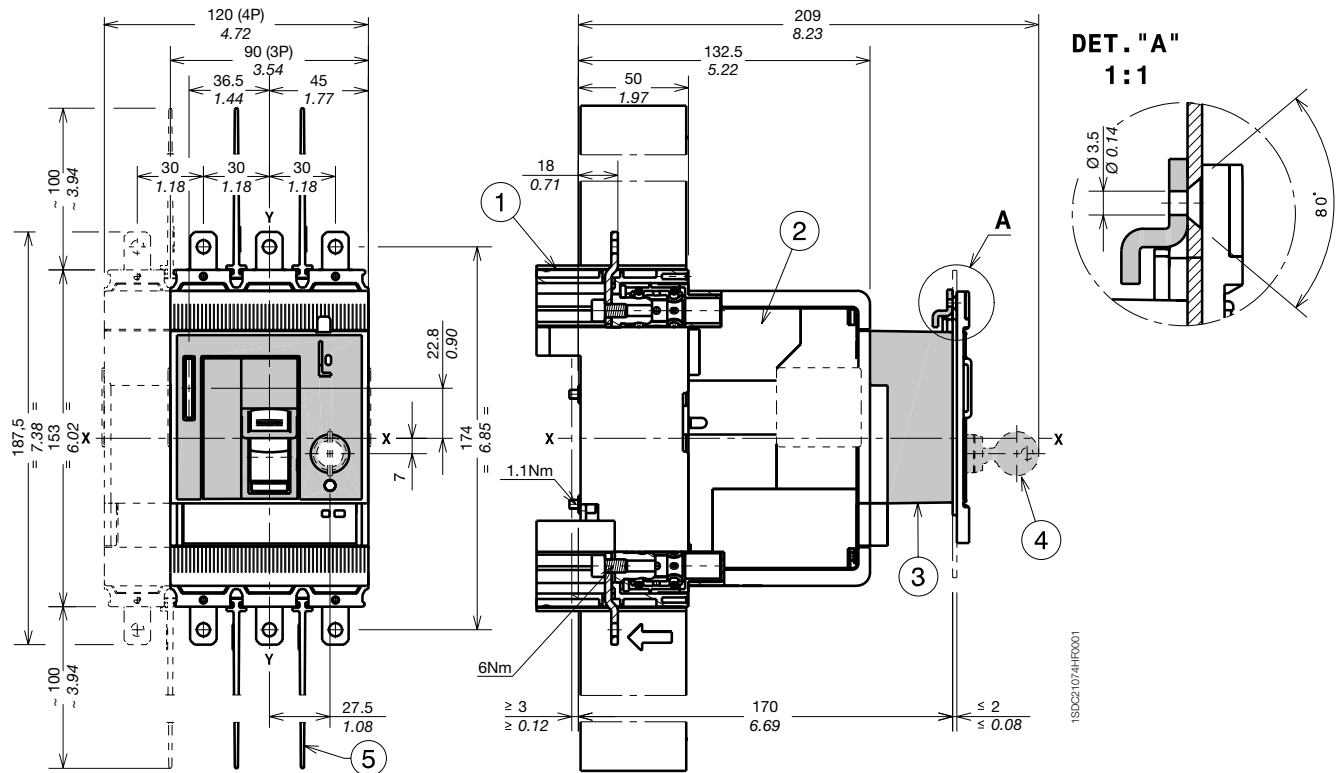

Captions

- ① Fixed part
- ② Moving part
- ③ Front for lever operating mechanism (FLD)
- ④ Key lock (not provided)
- ⑤ 100mm insulating barriers between phases (compulsory) provided
- ⑥ Drilling template of door with direct rotary handle with flange
- ⑦ Drilling template of door with direct rotary handle without flange

Overall dimensions

Tmax XT2 - Accessories for plug-in circuit breaker

Ekip Display or Ekip LED Meter

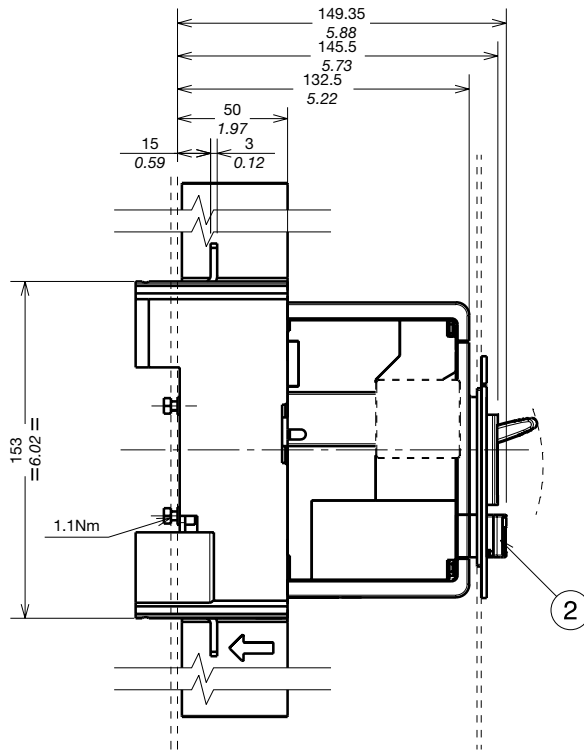
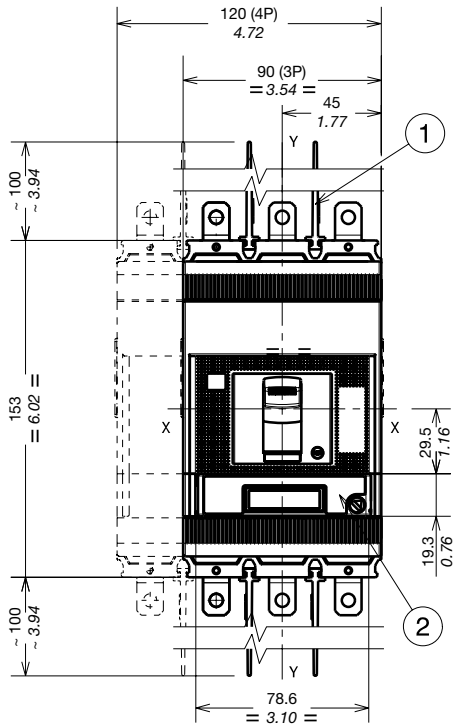

MOUNTING AT 50mm

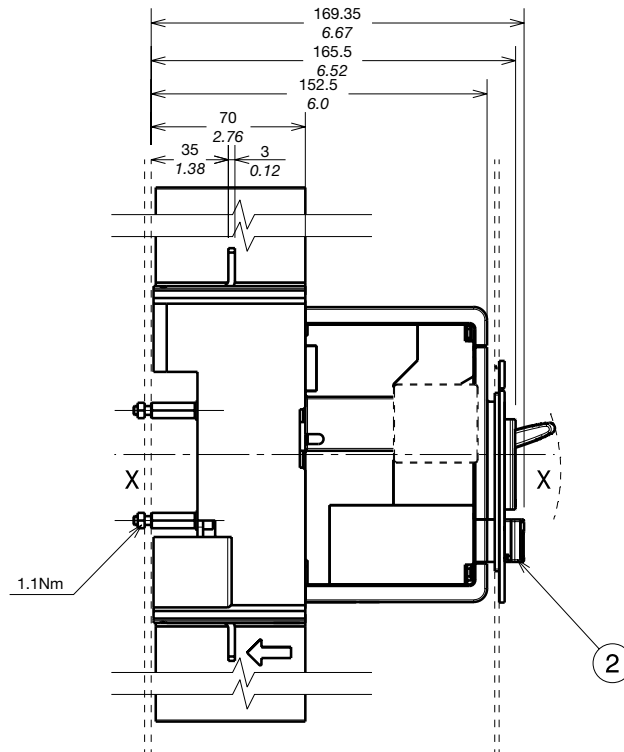

MOUNTING AT 50mm

Captions

- ① 100mm insulating barriers between phases
- ② Ekip Display or Ekip LED Meter

1SD021078FF0001

Residual current RC Sel

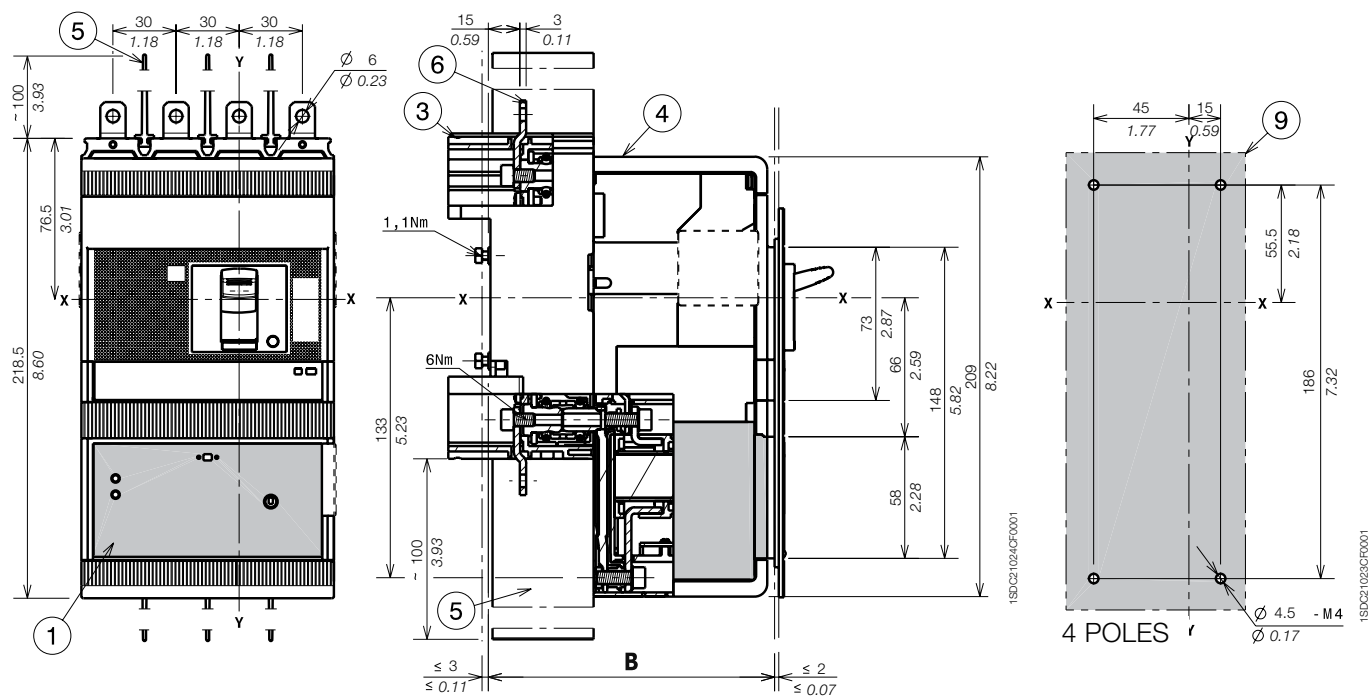

Captions

- ① Residual current
- ③ Fixed part
- ④ Moving part
- ⑤ 100mm insulating barriers between phases (compulsory) provided
- ⑥ Extended terminals
- ⑦ Drilling template of door with direct rotary handle and mounting with flange
- ⑧ Drilling template of door with direct rotary handle and mounting without flange
- ⑨ Drilling template for mounting circuit breaker on sheet

		A
With standard flange	IV	136
Without flange	IV	133,5

Overall dimensions

Tmax XT2 - Installation for withdrawable circuit breaker

Fixing on the backplate

DET. "B"
1:1

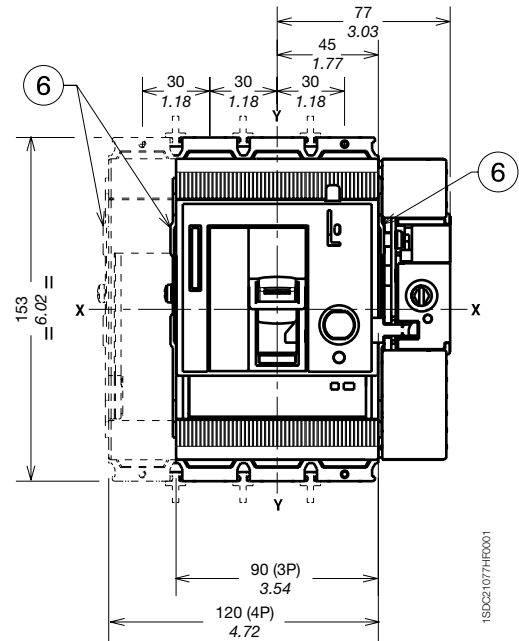
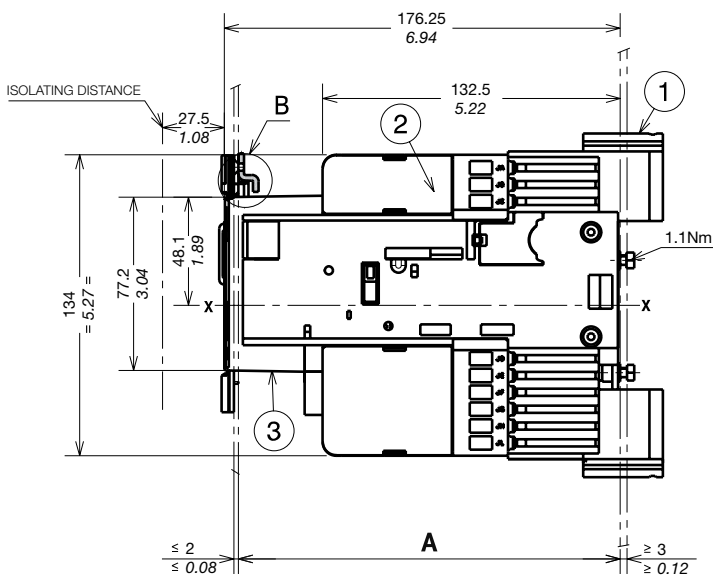
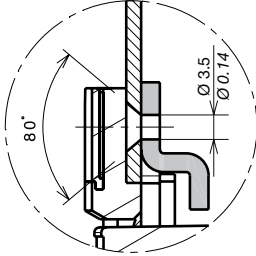

Captions

- ① Fixed part
- ② Moving part
- ③ FLD (FLD or RHD or RHE or MOE) compulsory for withdrawable version
- ⑥ Optional wiring ducts

			A
With standard flange	III - IV	Mounting at 50mm	170
	III - IV	Mounting at 70mm for extended front terminals	190

Drilling templates for the backplate

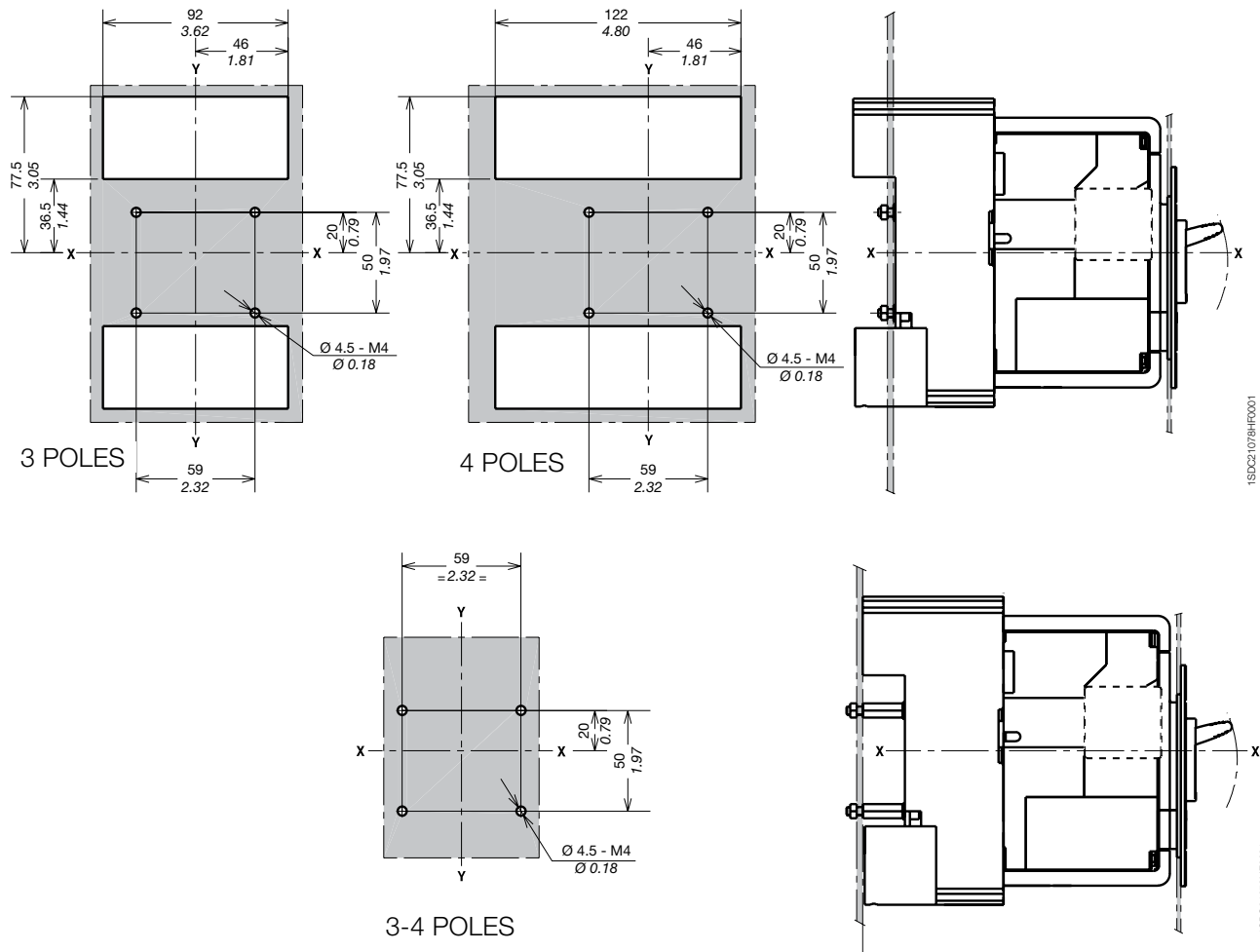

Flanges

Captions

- ⑤ Flange for circuit breaker III-IV withdrawable
- ⑥ Flange for withdrawable circuit breakers III IV with direct rotary handle RHD
- ⑦ Flange for withdrawable circuit breakers III IV with front extended terminals

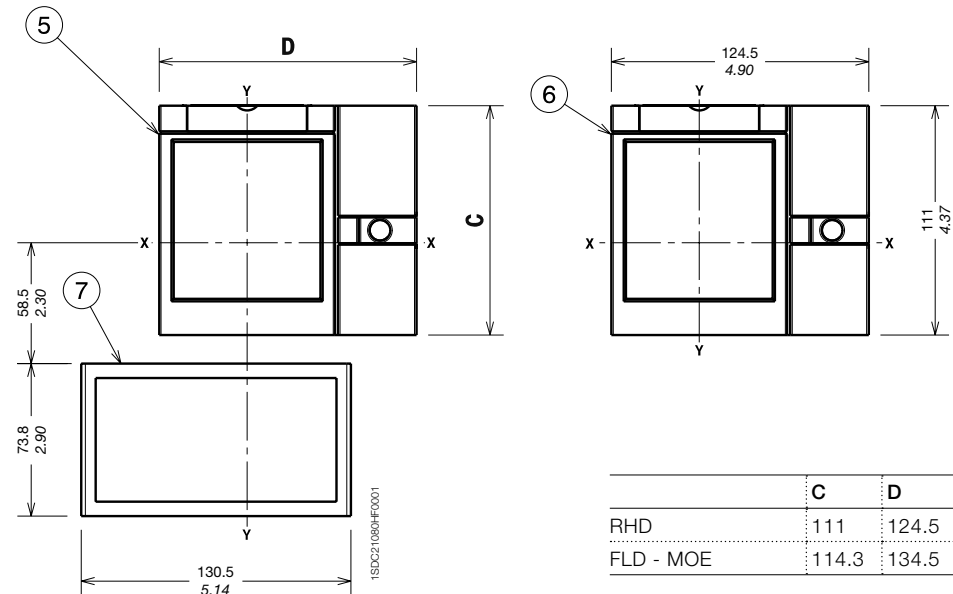

	C	D
RHD	111	124.5
FLD - MOE	114.3	134.5

Overall dimensions

Tmax XT2 - Installation for withdrawable circuit breaker

Drilling templates compartment door

With standard flange

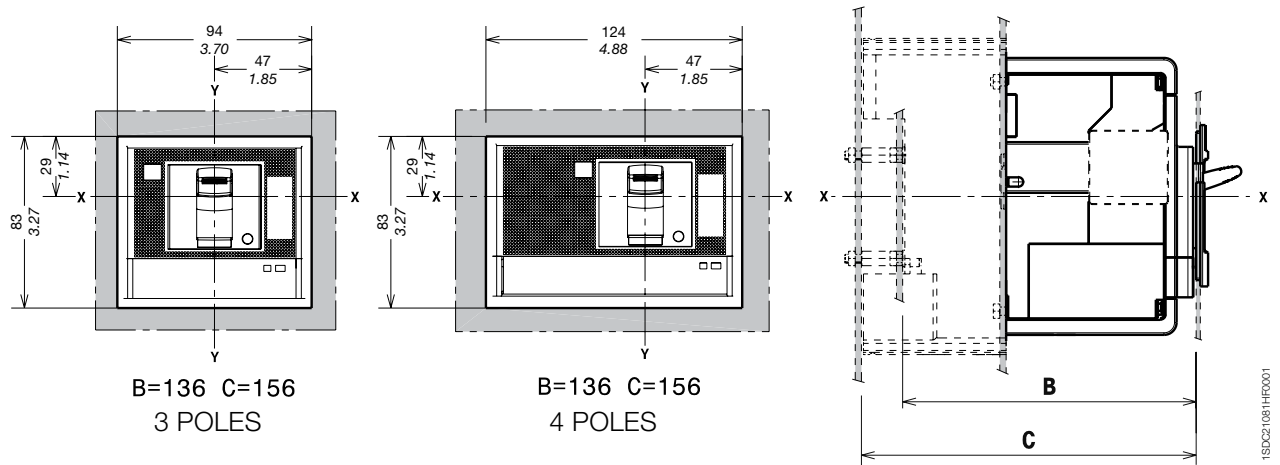

Without flange

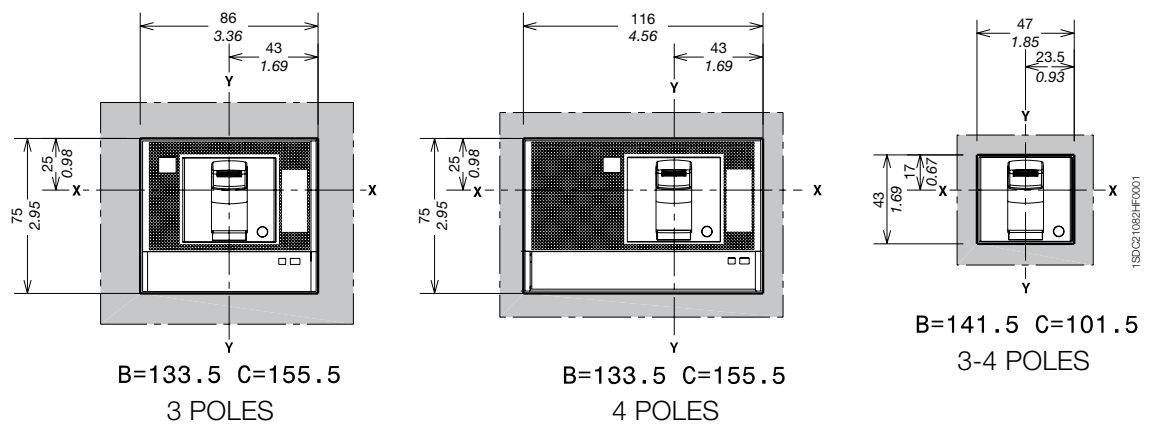

With optional flange

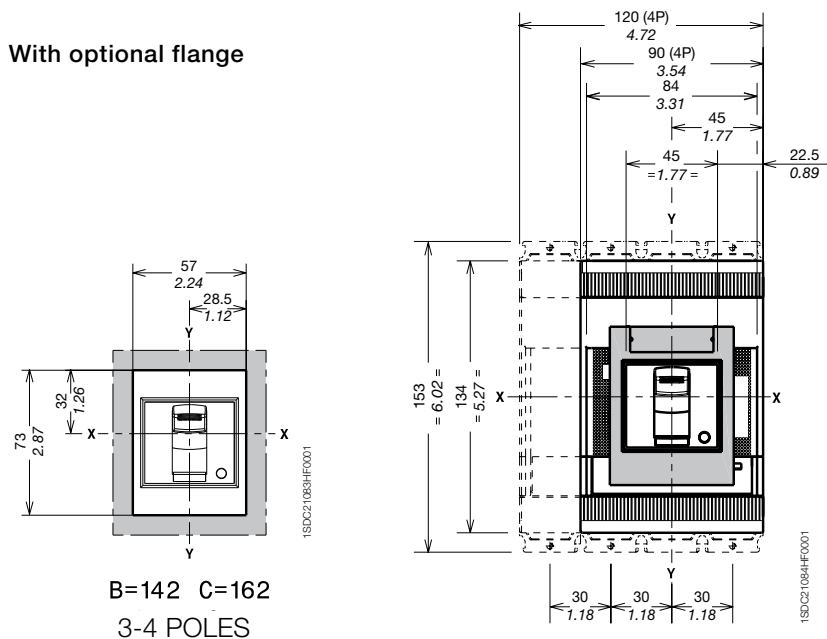

Overall dimensions

Tmax XT2 - Terminals for withdrawable circuit breaker

Terminals EF

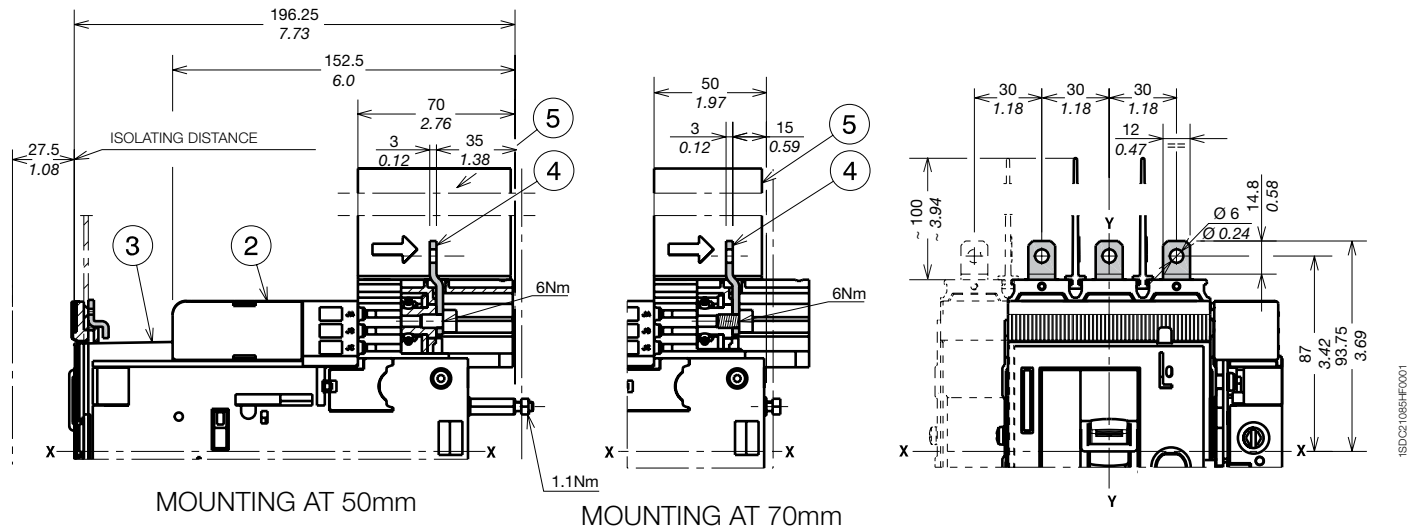

Captions

- ② Moving part
- ③ FLD (FLD or RHD or RHE or MOE) compulsory for withdrawable version
- ④ Front extended terminals
- ⑤ 100mm insulating barriers between phases (compulsory) provided

Note: insulated plate (compulsory) provided

Overall dimensions

Tmax XT2 - Terminals for withdrawable circuit breaker

Terminals ES

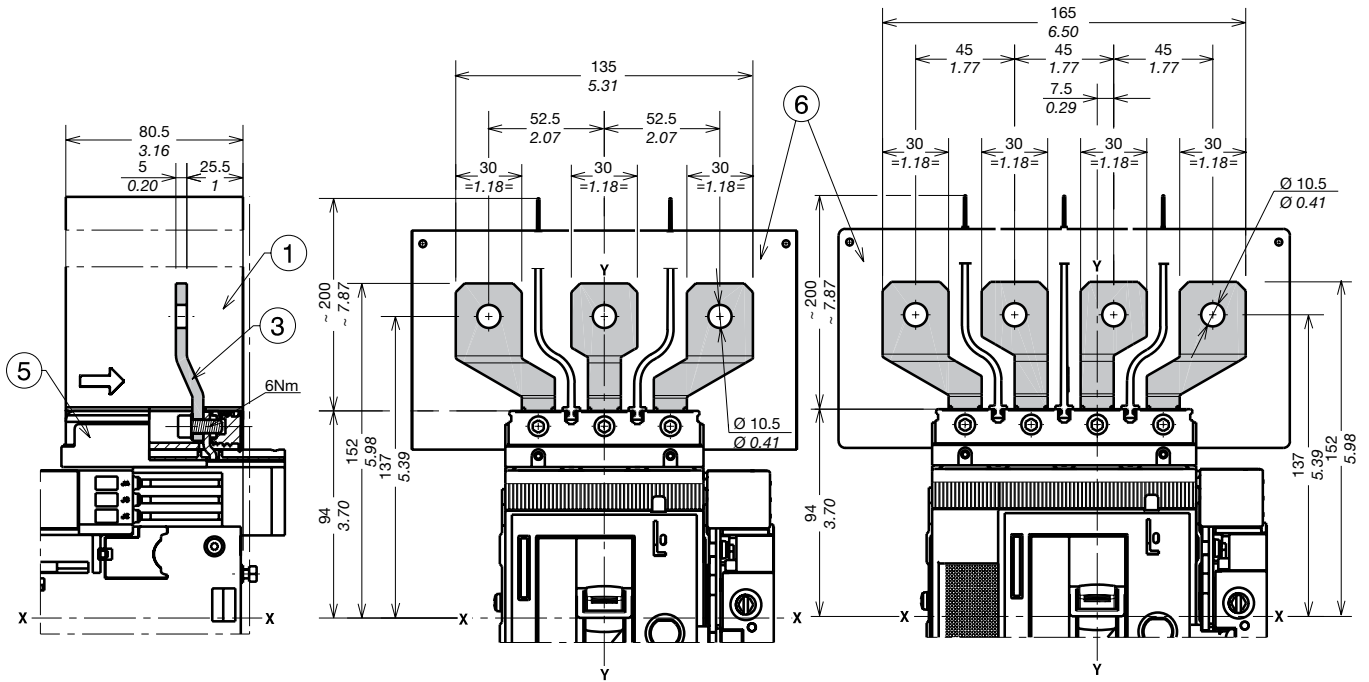

MOUNTING AT 50mm

Captions

- ① 200mm insulating barriers between phases (compulsory) provided
- ③ Front extended spread terminals
- ⑤ Adapter (compulsory) not provided
- ⑥ Insulated plate (compulsory) provided
- ⑦ Drilling template for 3p circuit breaker Ue>440V (compulsory)
- ⑧ Drilling template for 4p circuit breaker Ue>440V (compulsory)

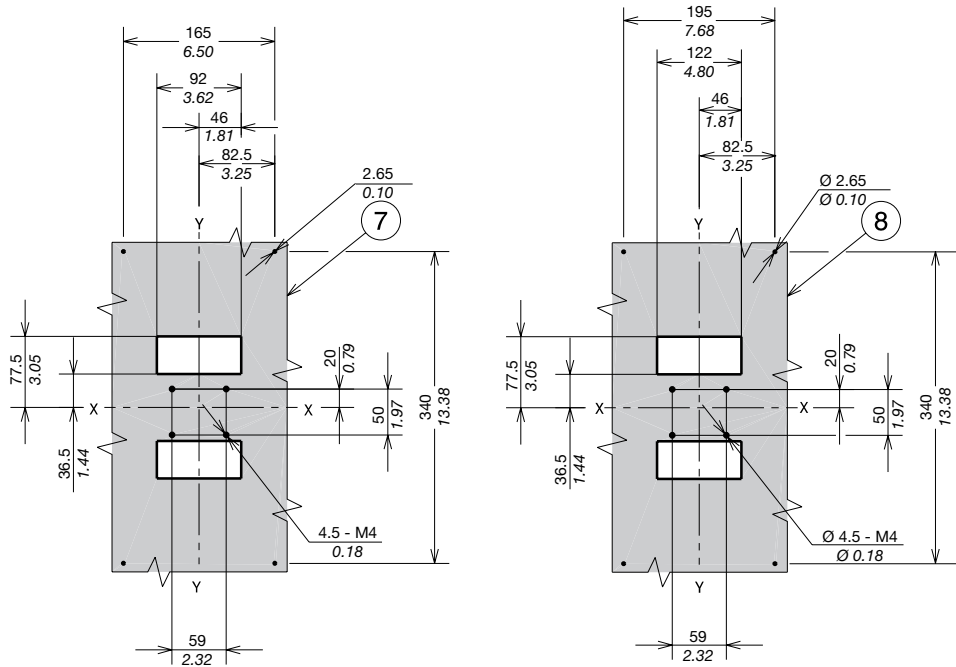

1SXU21096HF001

Terminals FCCu

Captions

- ② Terminals FCCu
- ④ Adapter (compulsory) not provided
- ⑤ 25mm insulating barriers between phases (compulsory) provided as standard with the circuit breaker

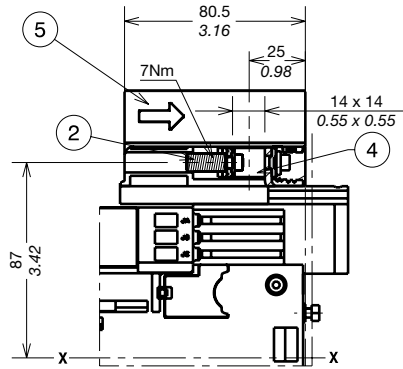

MOUNTING AT 50mm

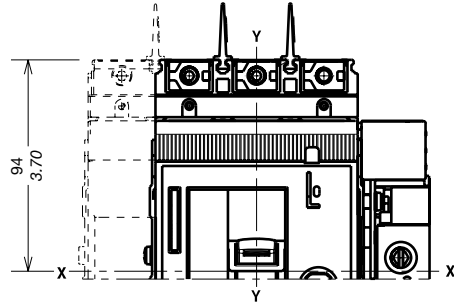

1SDC21090JH001

Overall dimensions

Tmax XT2 - Terminals for withdrawable circuit breaker

Terminals MC

Captions

- ① Multi-cable terminals
- ③ High terminal covers with degree of protection IP40 (optional) provided
- ④ Adapter (compulsory) not provided

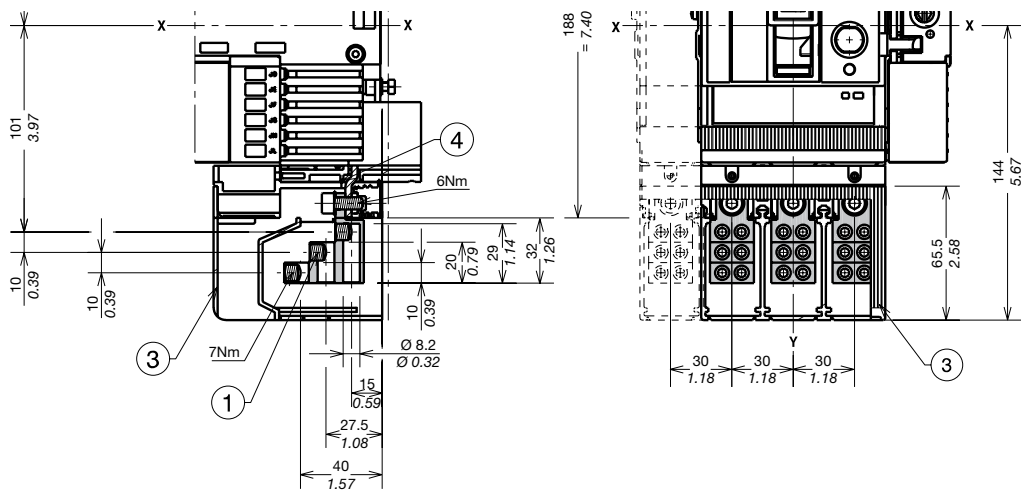

MOUNTING AT 50mm

1SDC21091HF001

Terminals HR/VR

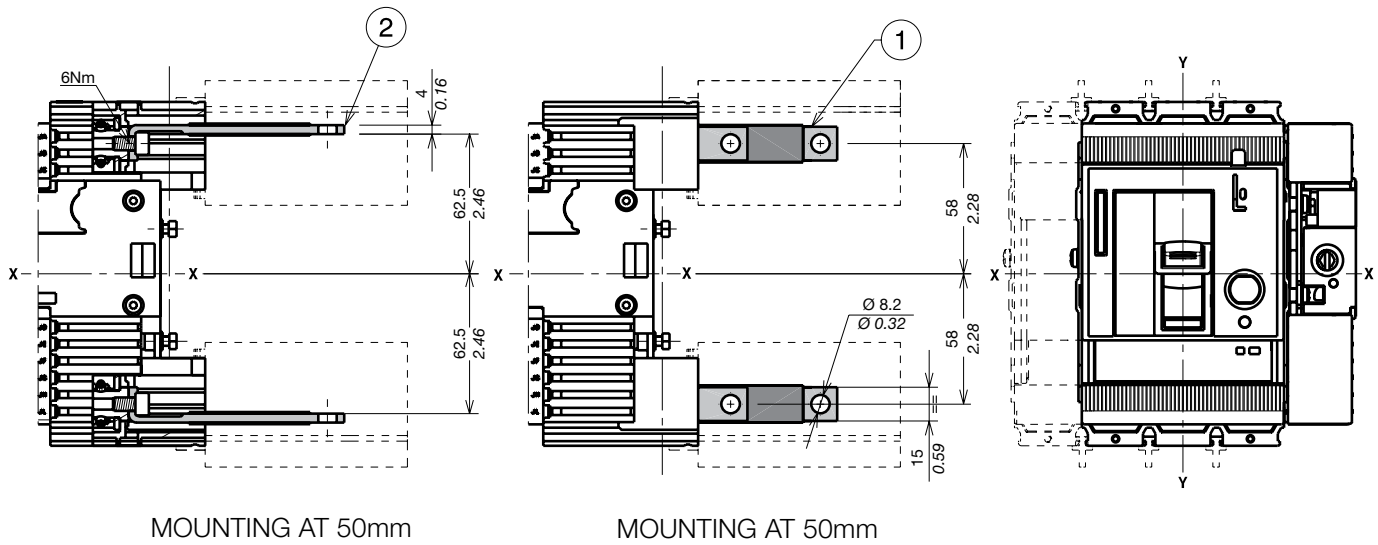

MOUNTING AT 50mm

MOUNTING AT 50mm

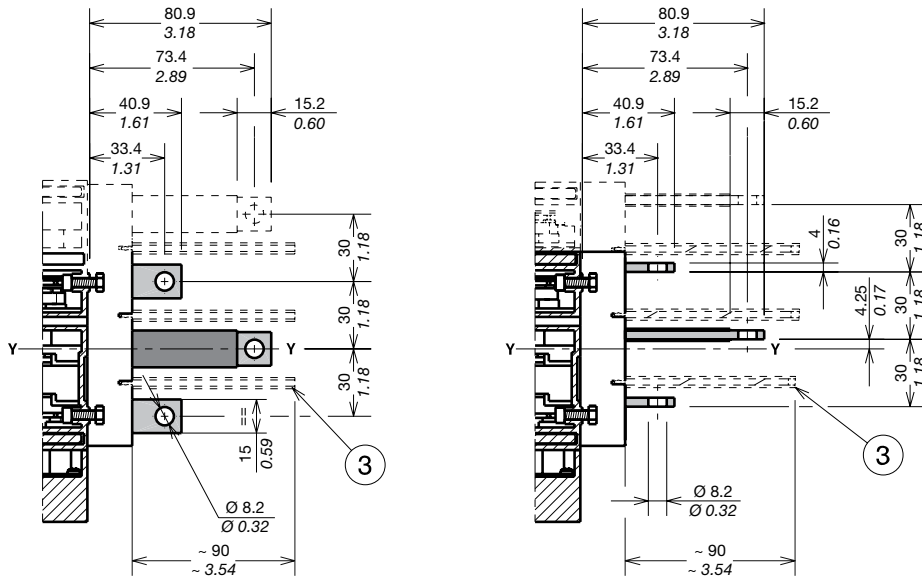

1SDC210021-FC001

Captions

- ① Rear vertical terminals
- ② Rear horizontal terminals
- ③ 90mm insulating barriers between phases (compulsory) not provided

Overall dimensions

Tmax XT2 - Accessories for withdrawable circuit breaker

Rotary handle operating mechanism on circuit breakers (RHD)

DET "B"

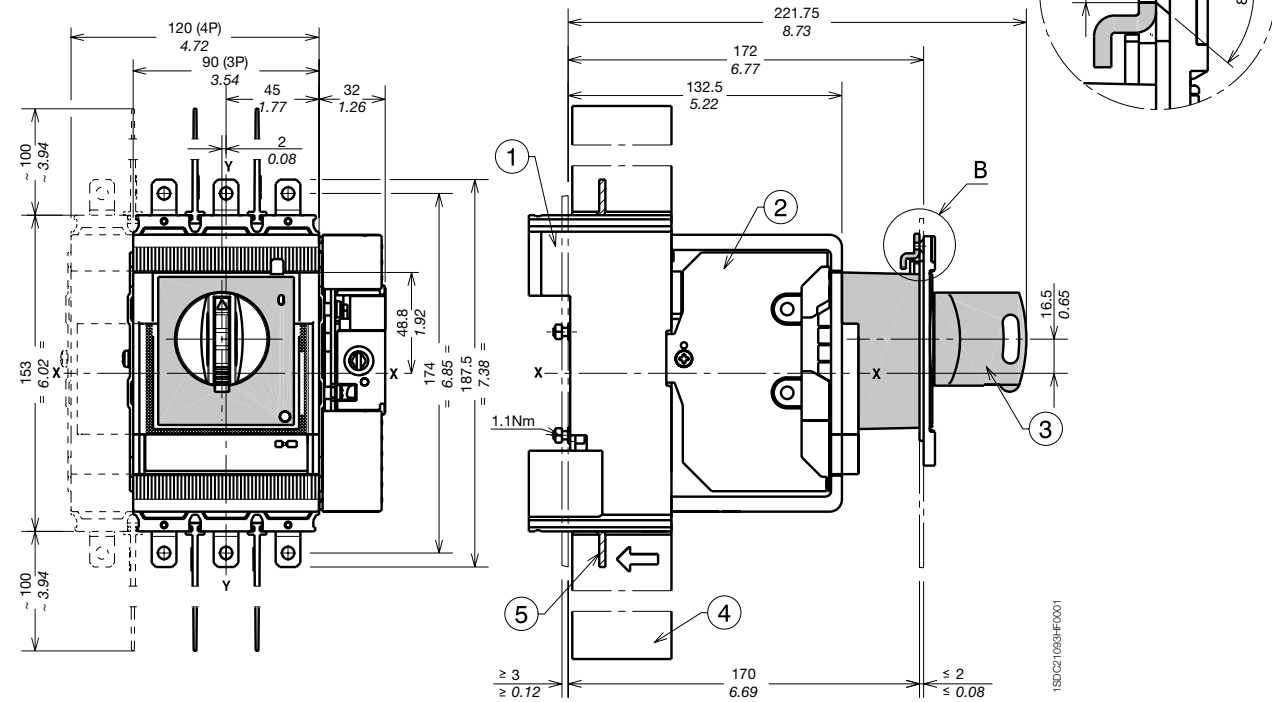

1SDC21094HF0001

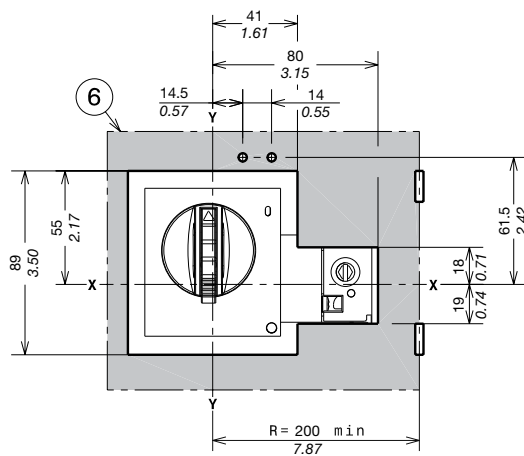

1SDC21094HF0001

Captions

- ① Fixed part
- ② Moving part
- ③ Rotary handle operating mechanism on circuit breaker
- ④ 100mm insulating barriers between phases (compulsory) provided
- ⑤ Extended terminals
- ⑥ Drilling template of door with direct rotary handle

Rotary handle operating mechanism on the compartment door (RHE)

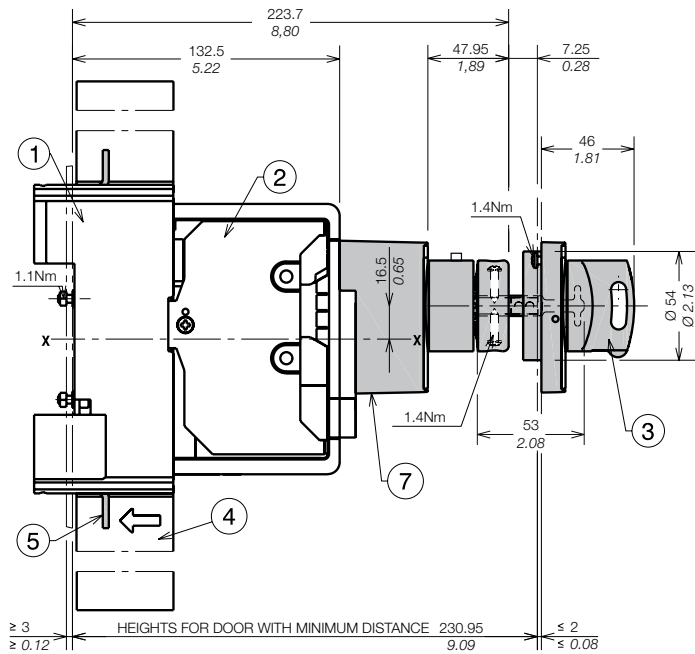
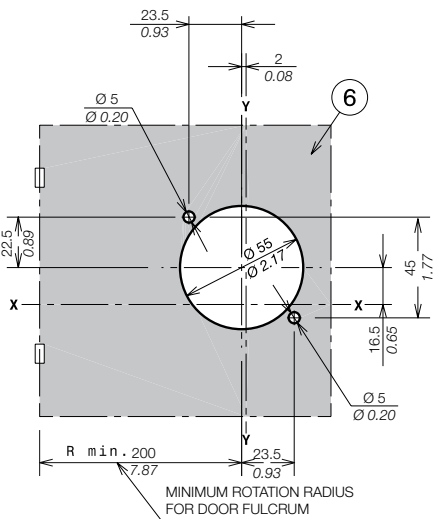
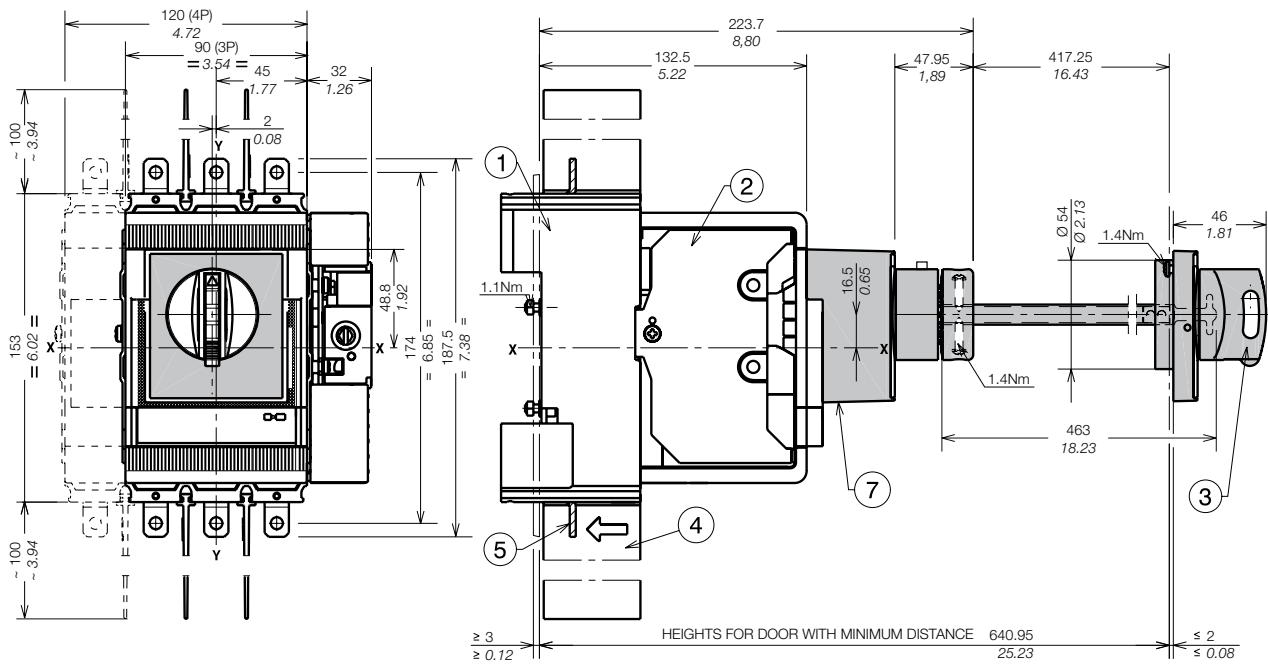

Captions

- ① Fixed part
- ② Moving part
- ③ Rotary handle operating mechanism on the compartment door (RHE)
- ④ 100mm insulating barriers between phases (compulsory) provided
- ⑤ Extended terminals
- ⑥ Door drilling template with extended rotary handle
- ⑦ Transmission unit

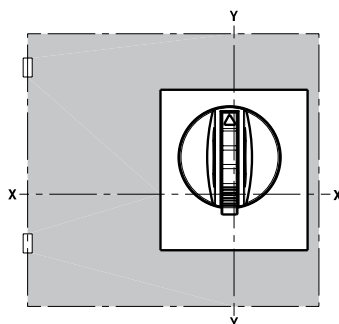

15DC2105HF0001

Overall dimensions

Tmax XT2 - Accessories for withdrawable circuit breaker

Stored energy motor operator (MOE)

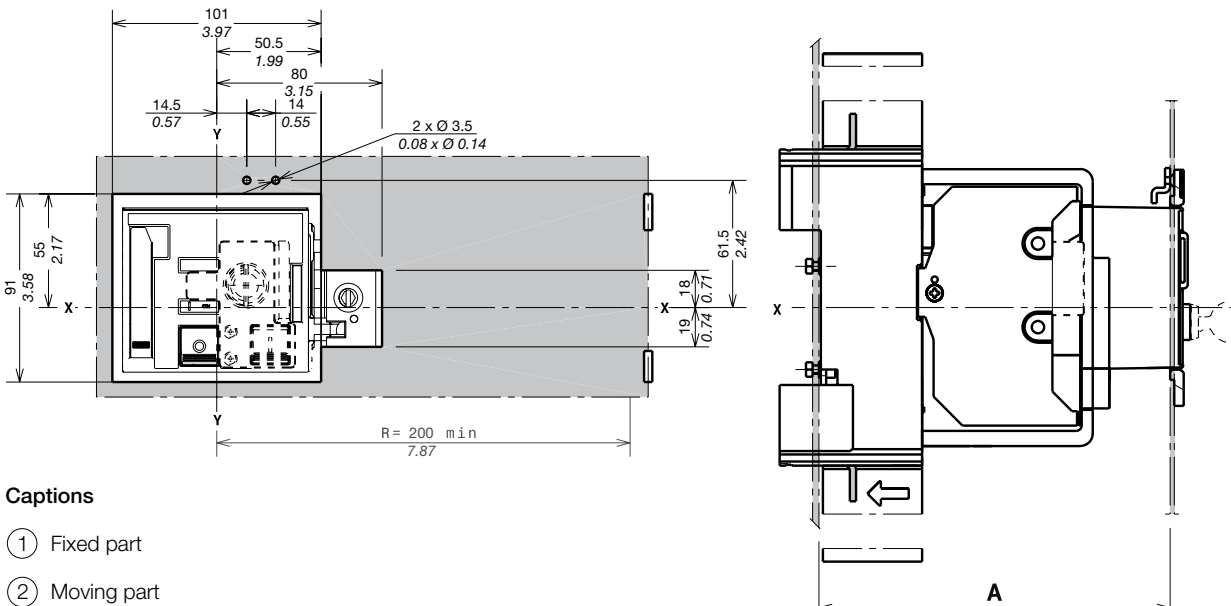
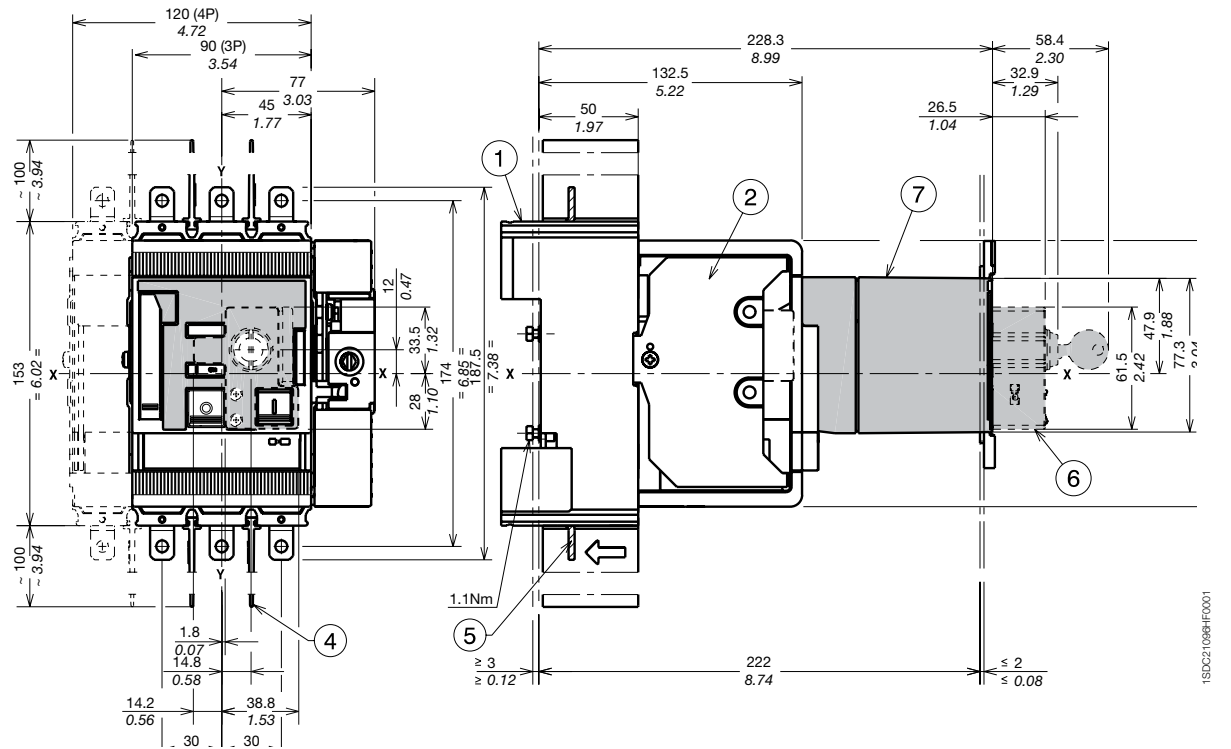

Captions

- ① Fixed part
- ② Moving part
- ④ 100mm insulating barriers between phases (compulsory) provided
- ⑤ Extended terminals
- ⑥ Key lock (not provided)
- ⑦ Stored energy motor operator (MOE)

	A
Motor operator MOE	III - IV 222

Front for lever operating (FLD)

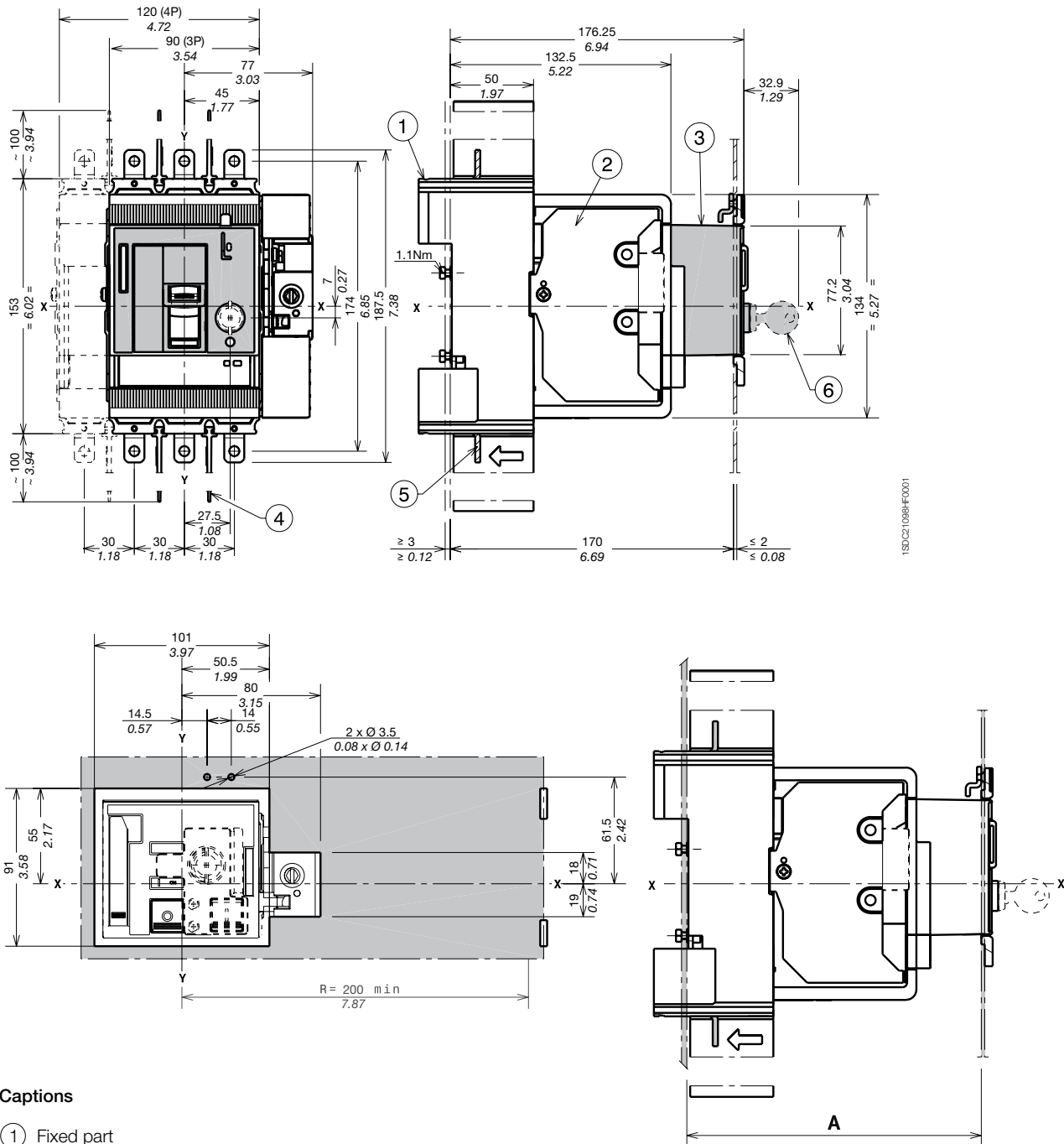

Captions

- ① Fixed part
- ② Moving part
- ③ Front for lever operating (FLD)
- ④ 100mm insulating barriers between phases (compulsory) provided
- ⑤ Extended terminals
- ⑥ Key lock (not provided)

		A
Front for lever operating FLD	III - IV	170

Overall dimensions

Tmax XT3 - Installation for fixed circuit breaker

Mounting on the backplate

Captions

- ① Insulating plate compulsory
- ② Overall dimension of optional wiring ducts
- ③ 25mm insulating barriers between phases (compulsory) provided
- ④ Front carter compulsory for through door of the panel $\leq 25\text{mm}/0,98''$

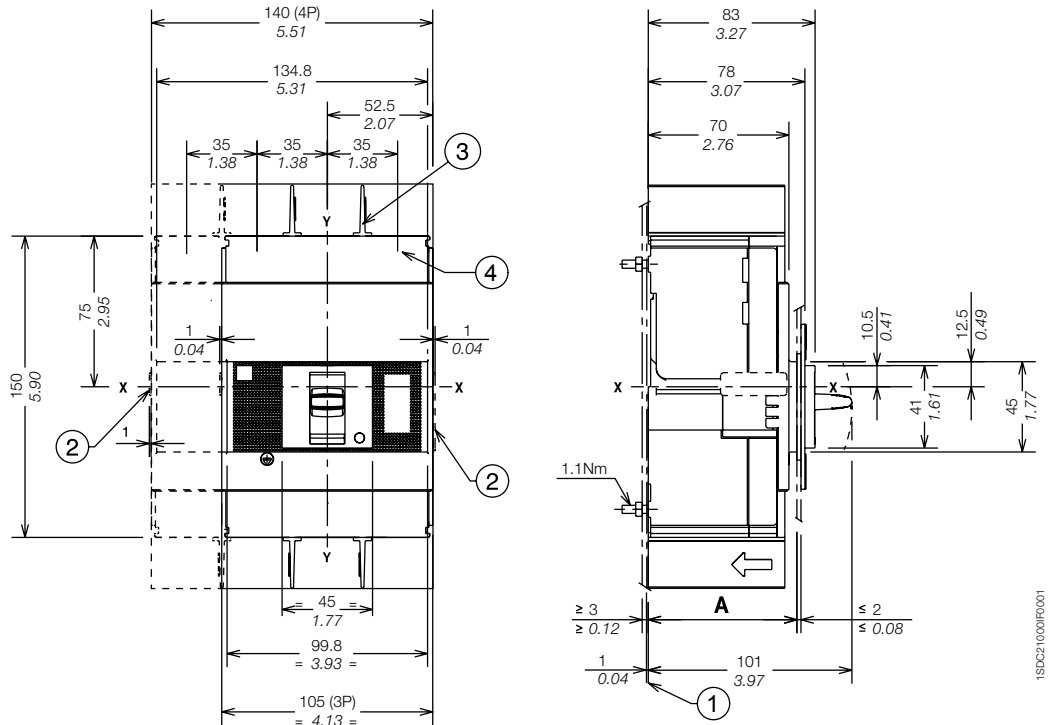

		A
With standard flange	III - IV	74
Without flange	III - IV	71
	III - IV	79

Mounting on DIN EN 50022 rail

Captions

- ① Mounting bracket
- ② Optional wiring ducts
- ③ Optional front cover for DIN rail
- ④ 25mm insulating barriers between phases (compulsory) provided

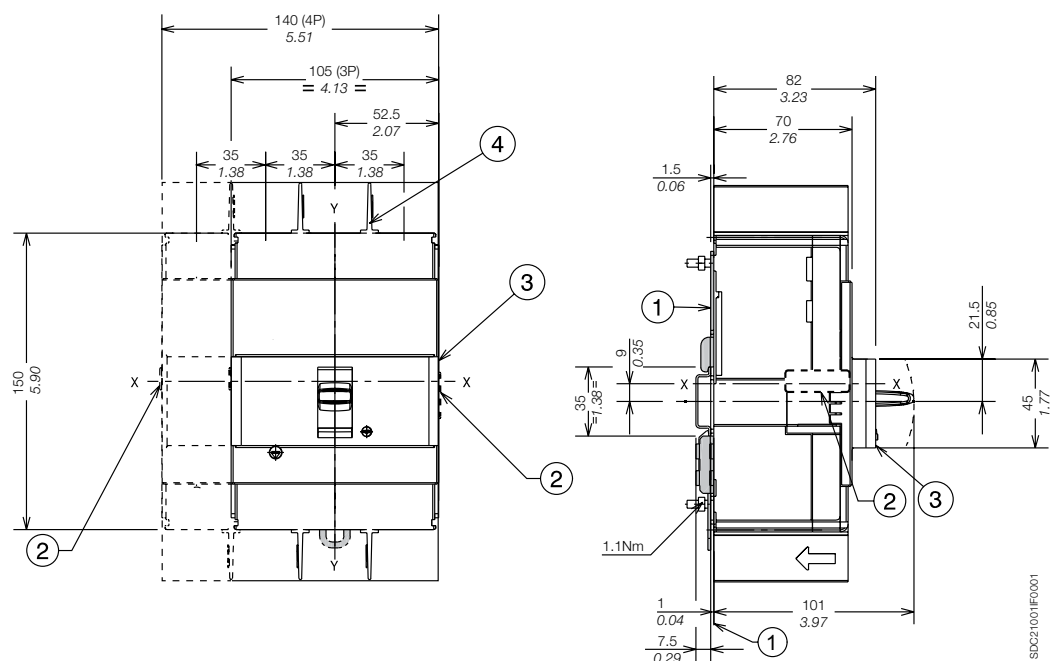

Drilling template

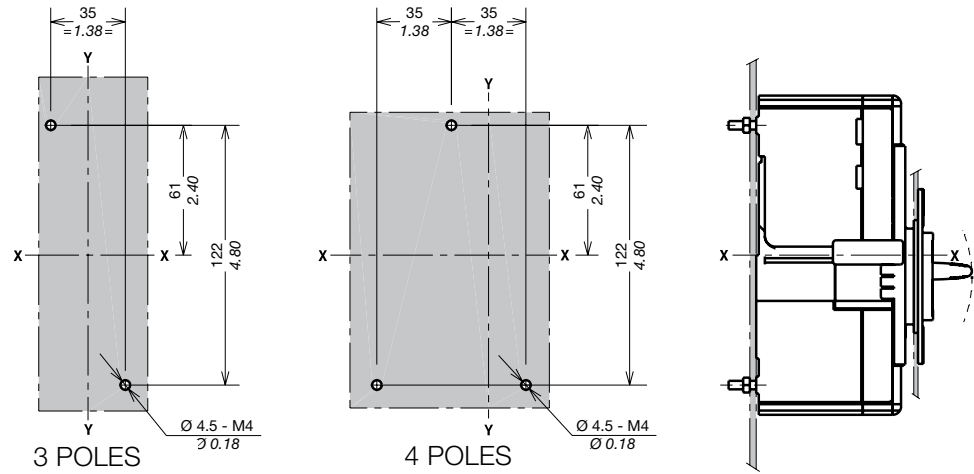

Flanges

Captions

- ① Flange for fixed circuit breaker III
- ② Flange for fixed circuit breaker IV
- ③ Flange for circuit breaker with direct motor operator MOD
- ④ Flange for circuit breaker with direct rotary handle (RHD)
- ⑤ Optional flange

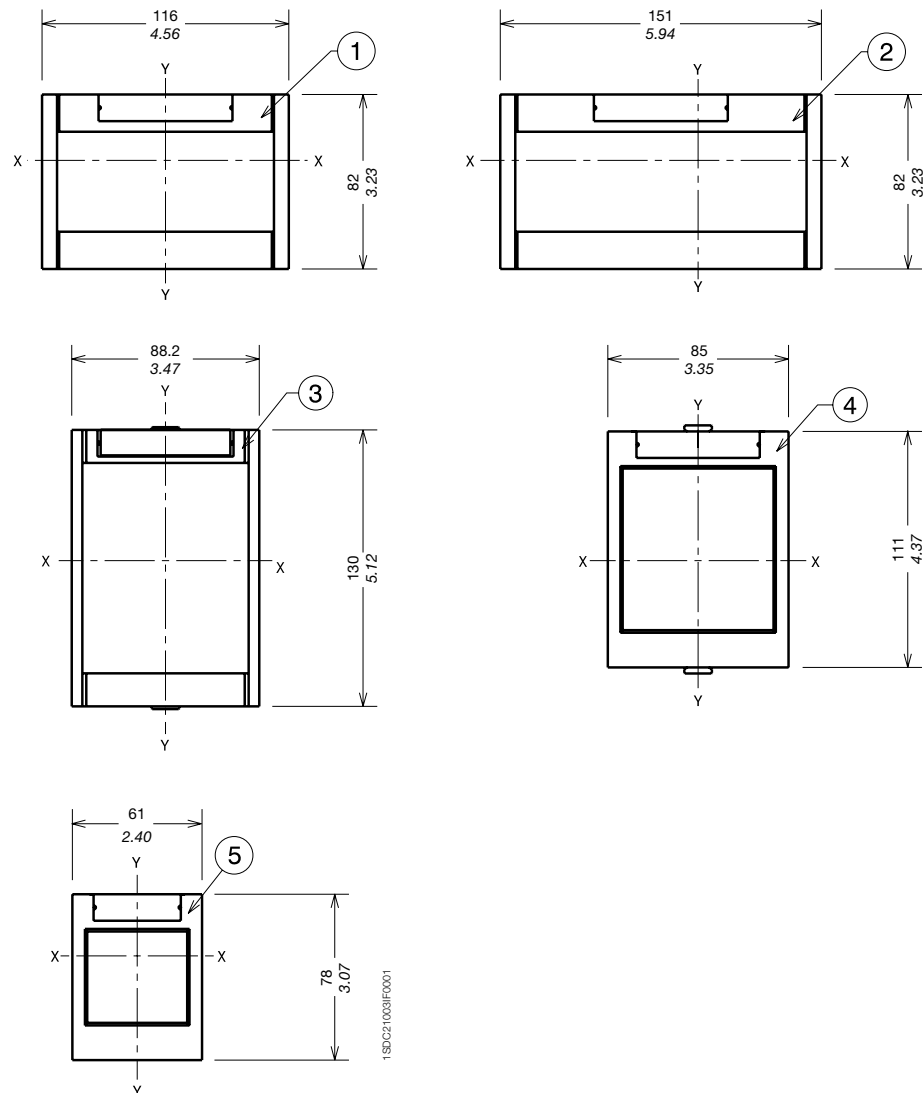

Overall dimensions

Tmax XT3 - Installation for fixed circuit breaker

Drilling templates for compartment door

With standard flange

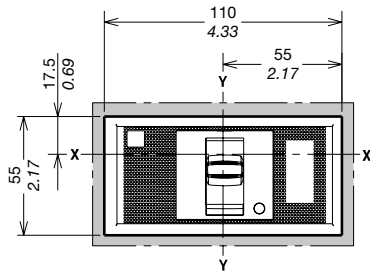

A=74
3 POLES

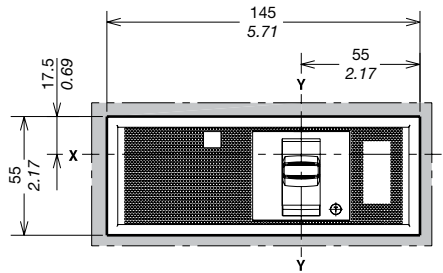

A=74
4 POLES

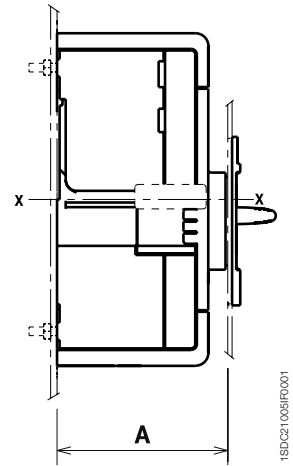

1SDC21008/F0001

Without flange

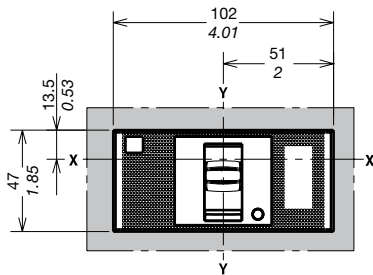

A=71
3 POLES

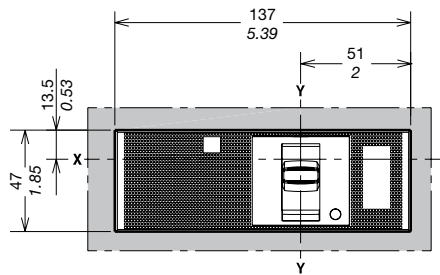

A=71
4 POLES

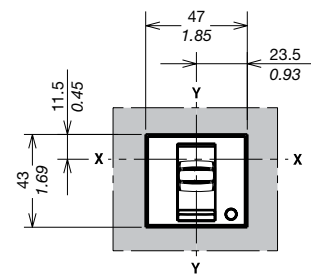

A=79
3-4 POLES

1SDC21008/F0001

With optional flange

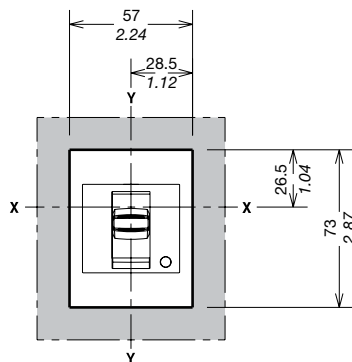

A=79
3-4 POLES

1SDC21007/F0001

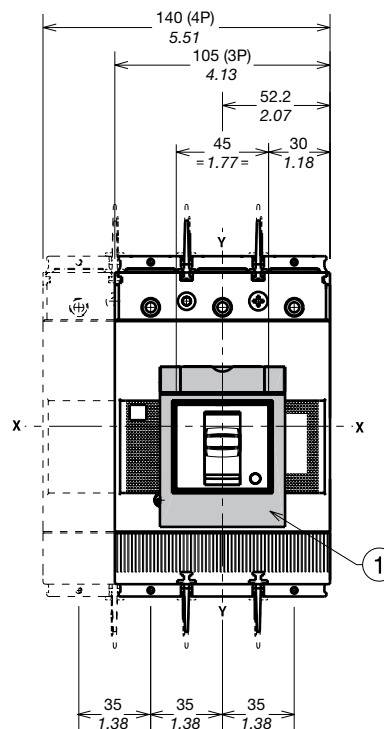

1SDC21008/F0001

Caption

- ① Optional flange

Overall dimensions

Tmax XT3 - Terminals for fixed circuit breaker

Terminals F

Captions

- ① Front terminals for busbar connection
- ⑦ 25mm insulating barriers between phases (compulsory) provided

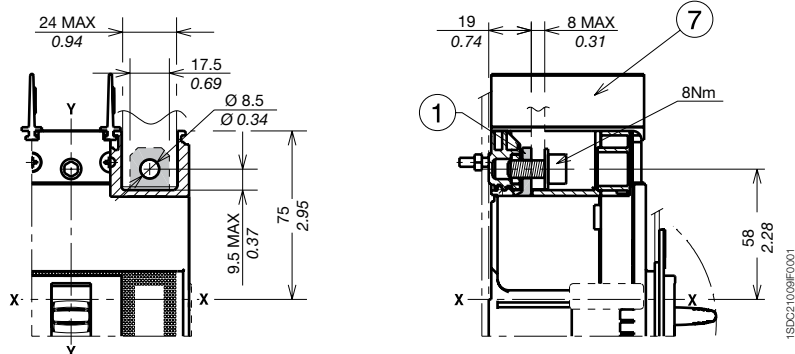

Terminals EF

Captions

- ② Front extended terminals
- ③ Terminal covers with degree of protection IP40 (optional) not provided
- ⑤ 100mm insulating barriers between phases (compulsory) provided

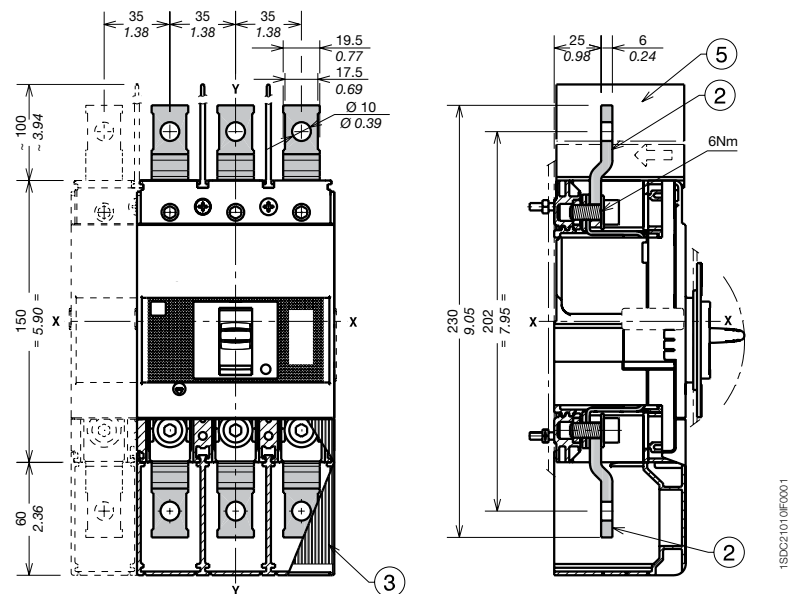

Terminals ES

Captions

- ④ Front extended spread terminals for busbar connection
- ⑥ 200mm insulating barriers between phases (compulsory) provided

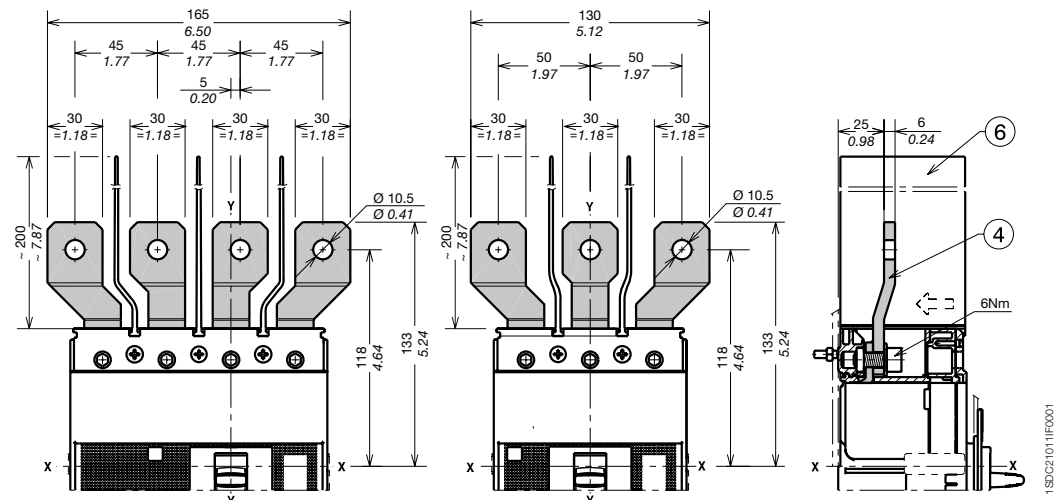

Overall dimensions

Tmax XT3 - Terminals for fixed circuit breaker

1x2,5...50mm² terminals FCCuAl

Captions

- ① 1x2,5...50mm² terminals FCCuAl
- ⑨ 25mm insulating barriers between phases (compulsory) provided as standard with the circuit breaker

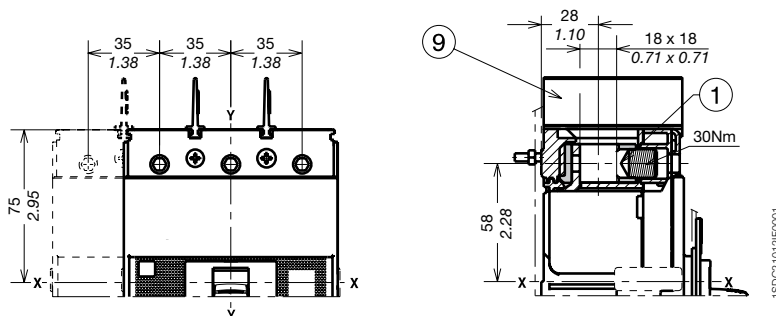

2x35...150mm² terminals FCCuAl

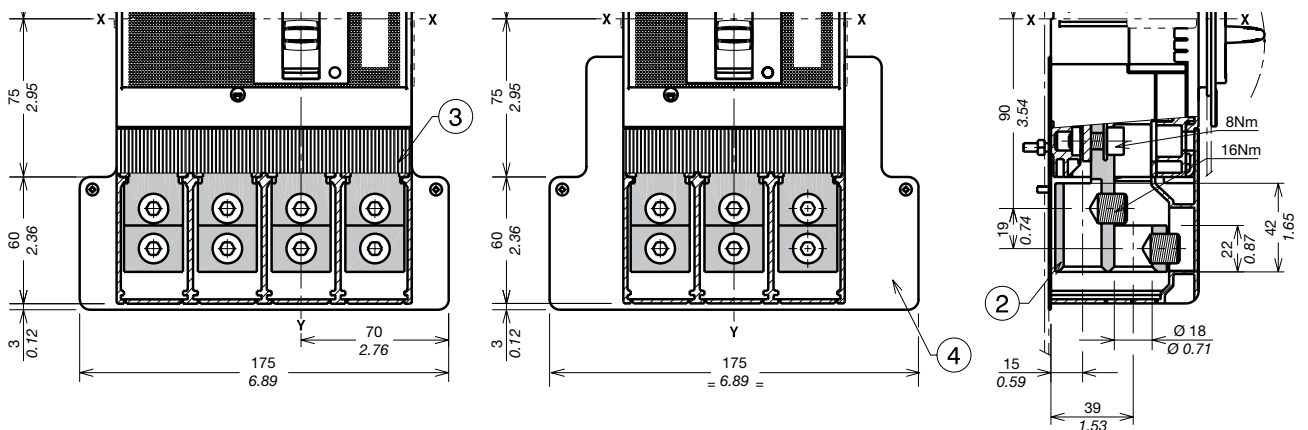

Captions

- ② 2x35...150mm² terminals FCCuAl
- ③ Terminal covers with degree of protection IP40 (optional) provided
- ④ Provided rear insulated plate (compulsory for CuAl 2x150mm² cables)
- ⑦ Drilling template for mounting circuit breaker on sheet III with rear insulated plate
- ⑧ Drilling template for mounting circuit breaker on sheet IV with rear insulated plate

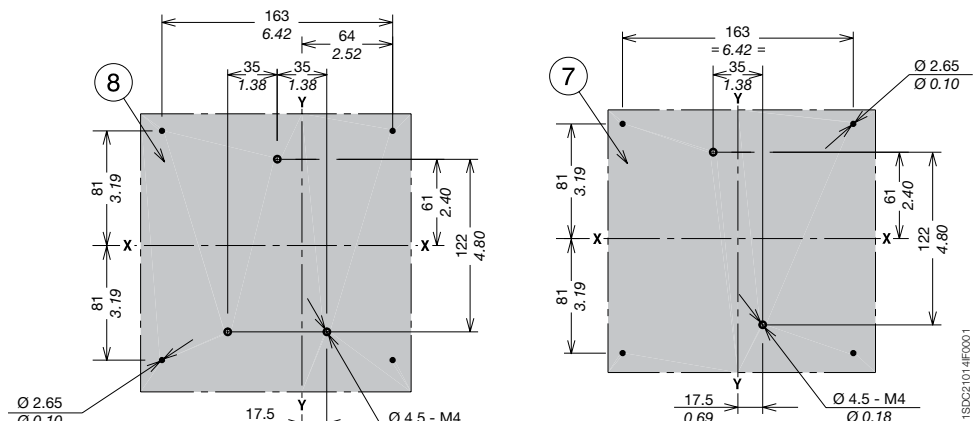

25...150mm² terminals FCCuAl

Captions

- ① 25...150mm² terminals FCCuAl
- ② 25mm insulating barriers between phases (compulsory) provided as standard with the circuit breaker

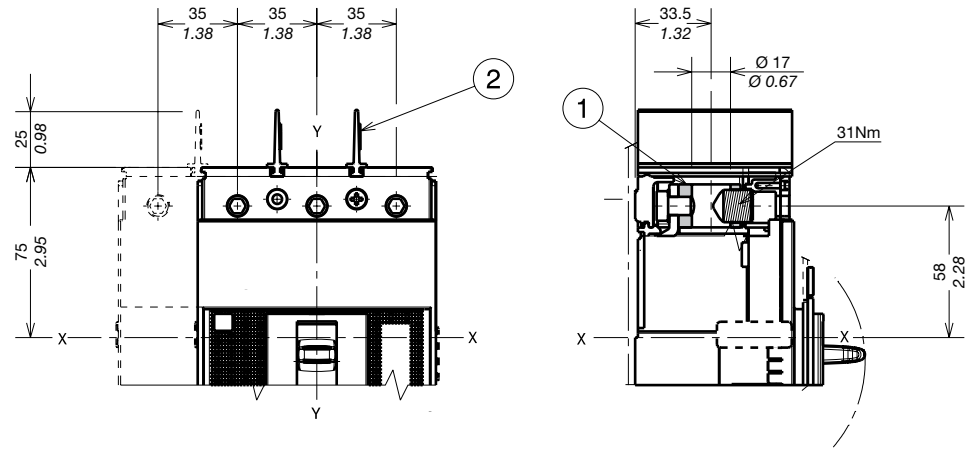

Terminals FCCu

Captions

- ⑥ Front terminals FCCu
- ⑨ 25mm insulating barriers between phases (compulsory) provided as standard with the circuit breaker

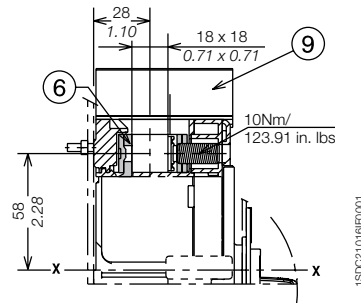

Terminals MC

Captions

- ③ Terminal covers with degree of protection IP40 (optional) provided
- ⑤ Front terminal for multi-cable connection

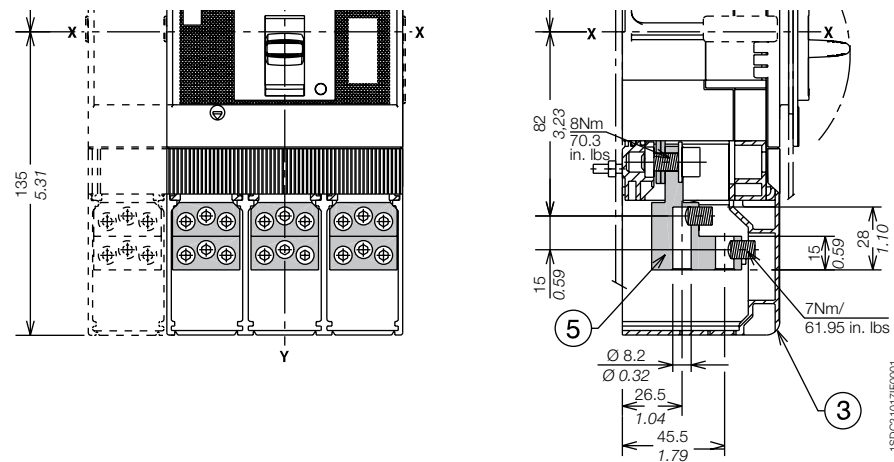

Overall dimensions

Tmax XT3 - Terminals for fixed circuit breaker

Terminals R

Captions

- ① Adjustable rear terminals
- ② Bottom terminal covers with degree of protection IP30 (optional) provided
- ③ Drilling template for mounting circuit breaker IV on sheet
- ④ Drilling template for mounting circuit breaker III on sheet

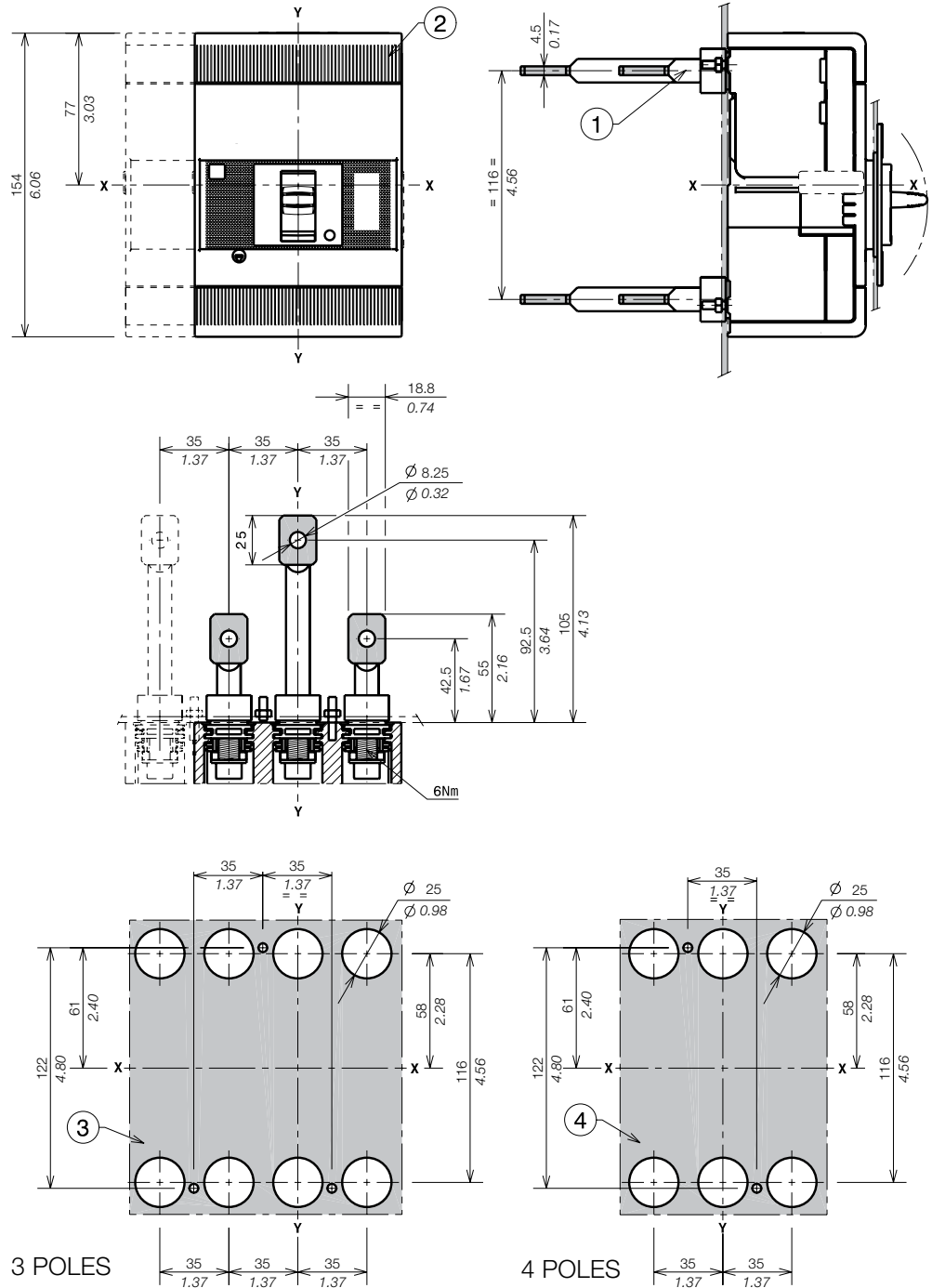

1SD21053C0001

Overall dimensions

Tmax XT3 - Accessories for fixed circuit breaker

Rotary handle operating mechanism on circuit breaker (RHD)

Captions

- ② Rotary handle operating mechanism on circuit breaker RHD
- ④ Drilling template of door with direct rotary handle
- ⑥ 25mm insulating barriers between phases (compulsory) provided as standard with the circuit breaker

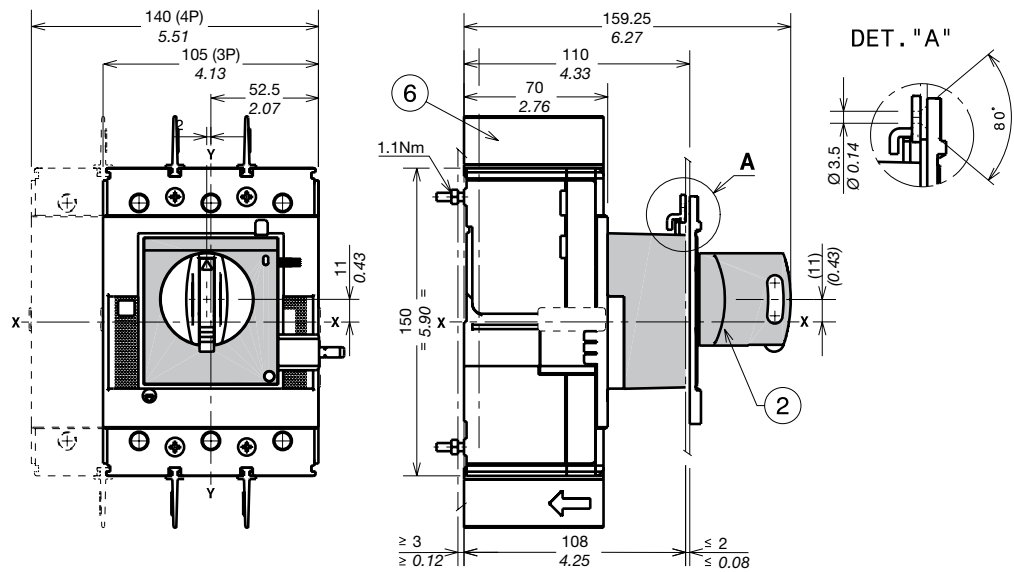

MINIMUM ROTATION RADIUS FOR DOOR FULCRUM

1SDXC21018RF0001

Overall dimensions

Tmax XT3 - Accessories for fixed circuit breaker

Rotary handle operating mechanism on the compartment door (RHE)

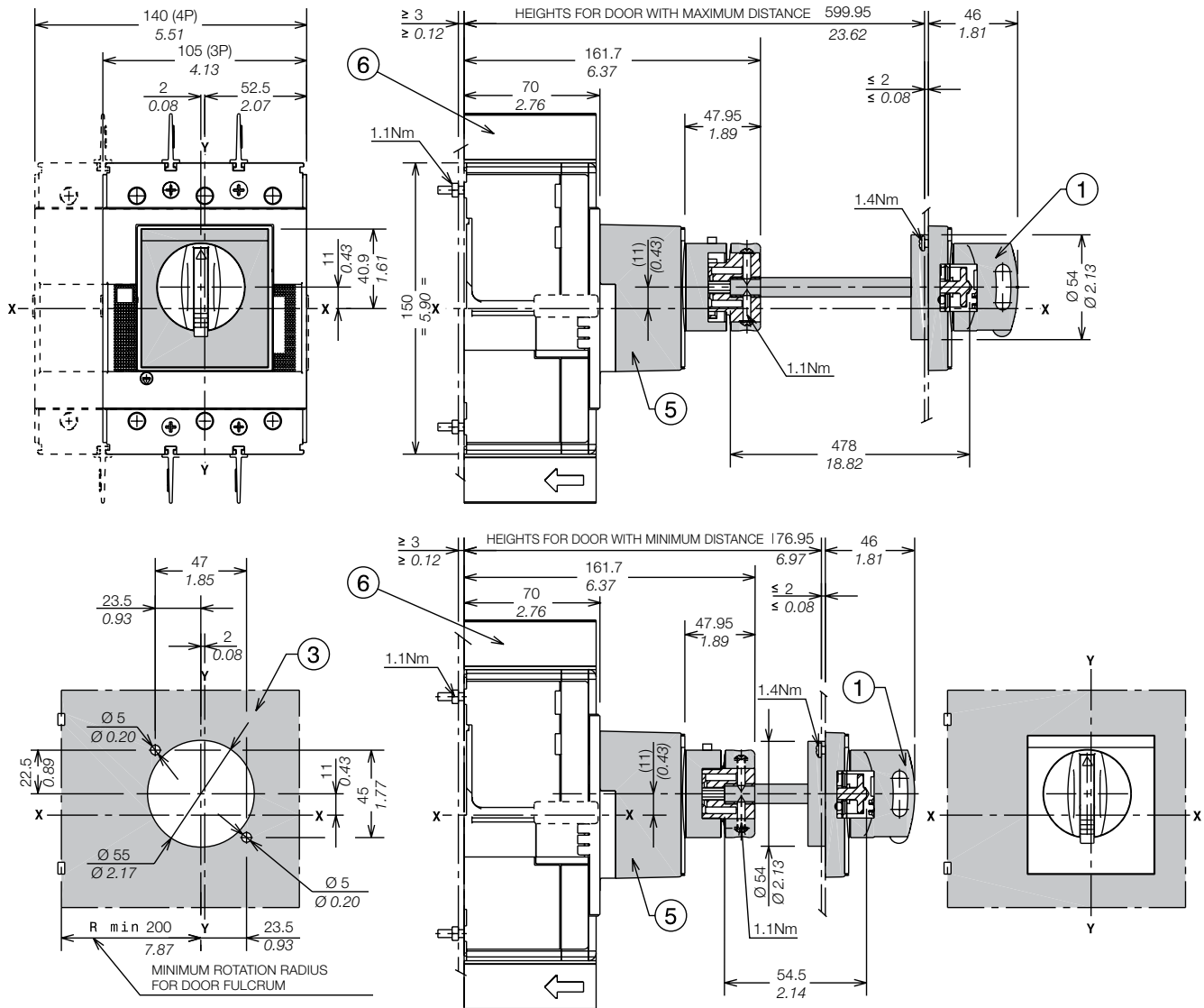

Captions

- ① Rotary handle operating mechanism on the compartment door (RHE)
- ③ Drilling template of door with extended rotary handle (RHE)
- ⑤ Transmission unit
- ⑥ 25mm insulating barriers between phases (compulsory) provided as standard with the circuit breaker

1SDXC2101RFD001

Large rotary handle operating mechanism on the compartment door (RHE-LH)

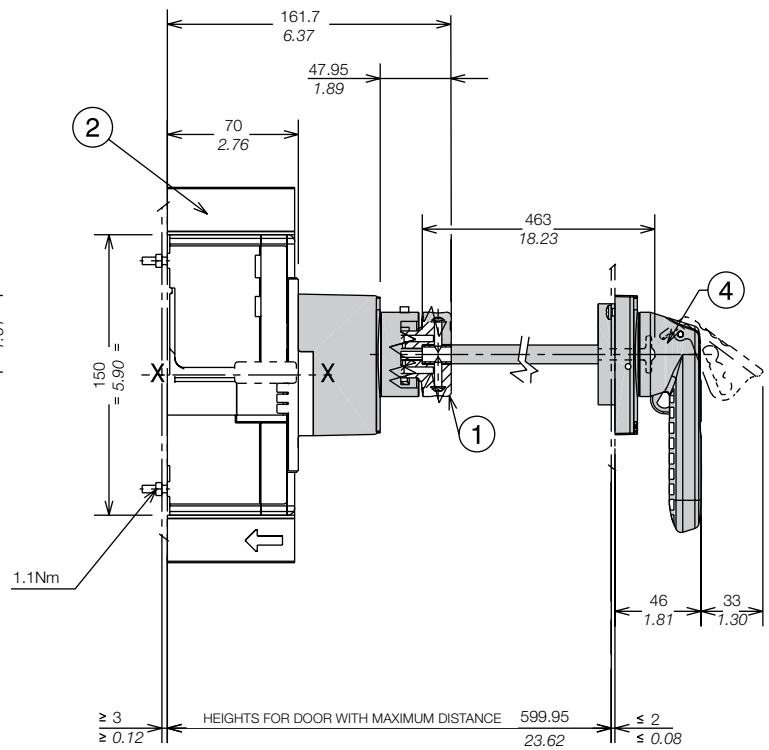
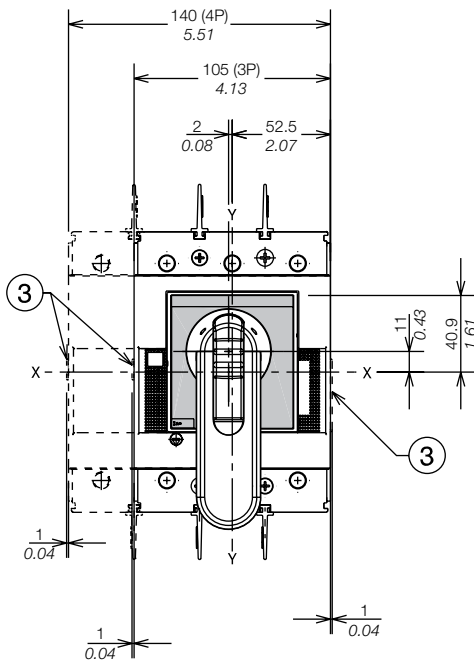

Captions

- ① Transmission unit
- ② 25mm insulating barriers between phases (compulsory) provided as standard with the circuit breaker
- ③ Optional wiring ducts
- ④ Large transmitted rotary handle
- ⑤ Drilling template of door with large transmitted rotary handle

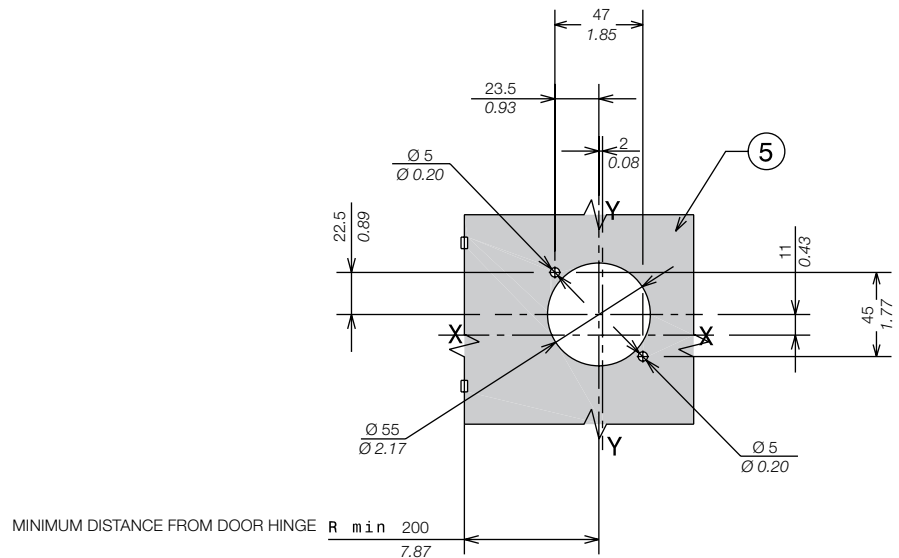

1SDC210201FX001

Overall dimensions

Tmax XT3 - Installation for plug-in circuit breaker

Direct motor operator (MOD)

Captions

- ③ Key lock (not provided)
- ④ Direct motor operator MOD
- ⑤ Drilling template of door with MOD with flange
- ⑥ Drilling template of door with MOD without flange
- ⑦ 25mm insulating barriers

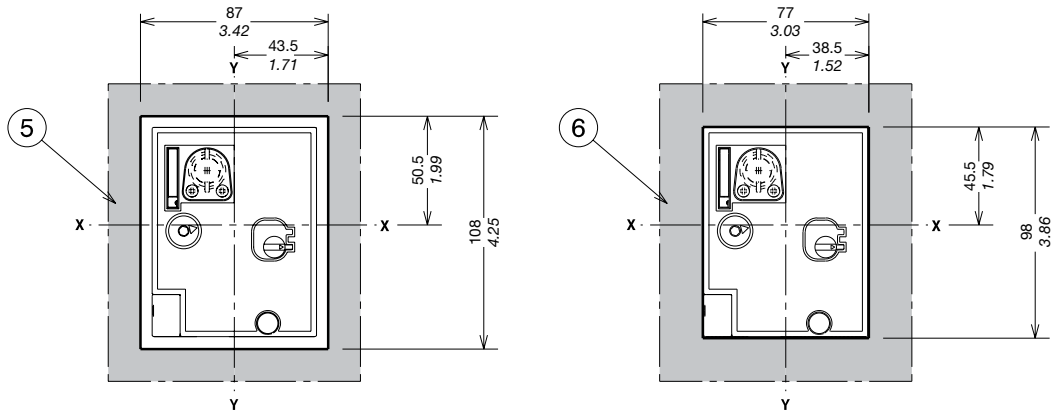
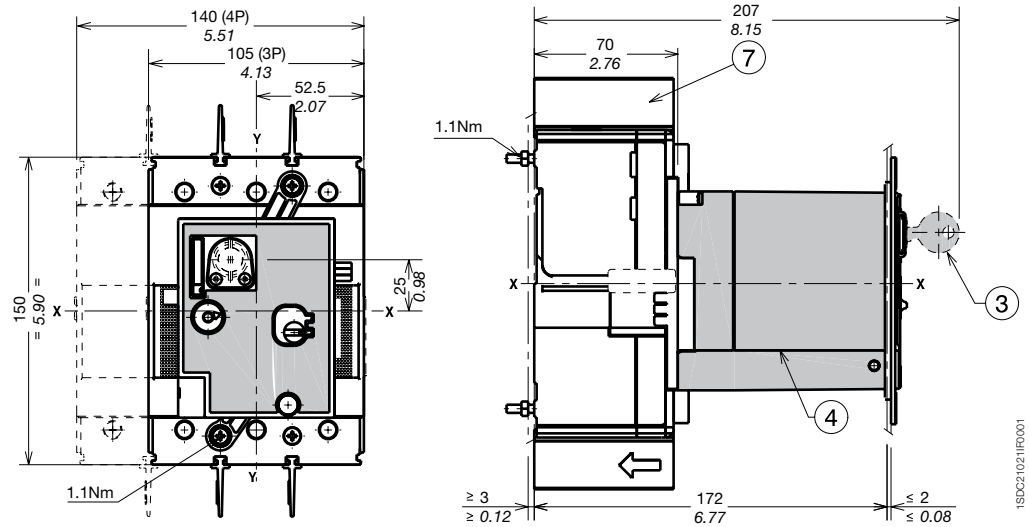

1SDC21021FR001

1SDC21022FR001

RC Inst and RC Sel residual current release for 3-pole circuit breaker

Captions

- ① Front terminals for cable connection
- ② Terminal covers with degree of protection IP40
- ③ Drilling template of door with direct rotary handle with flange
- ④ Drilling template of door with direct rotary handle without flange
- ⑤ Drilling template for mounting circuit breaker on sheet

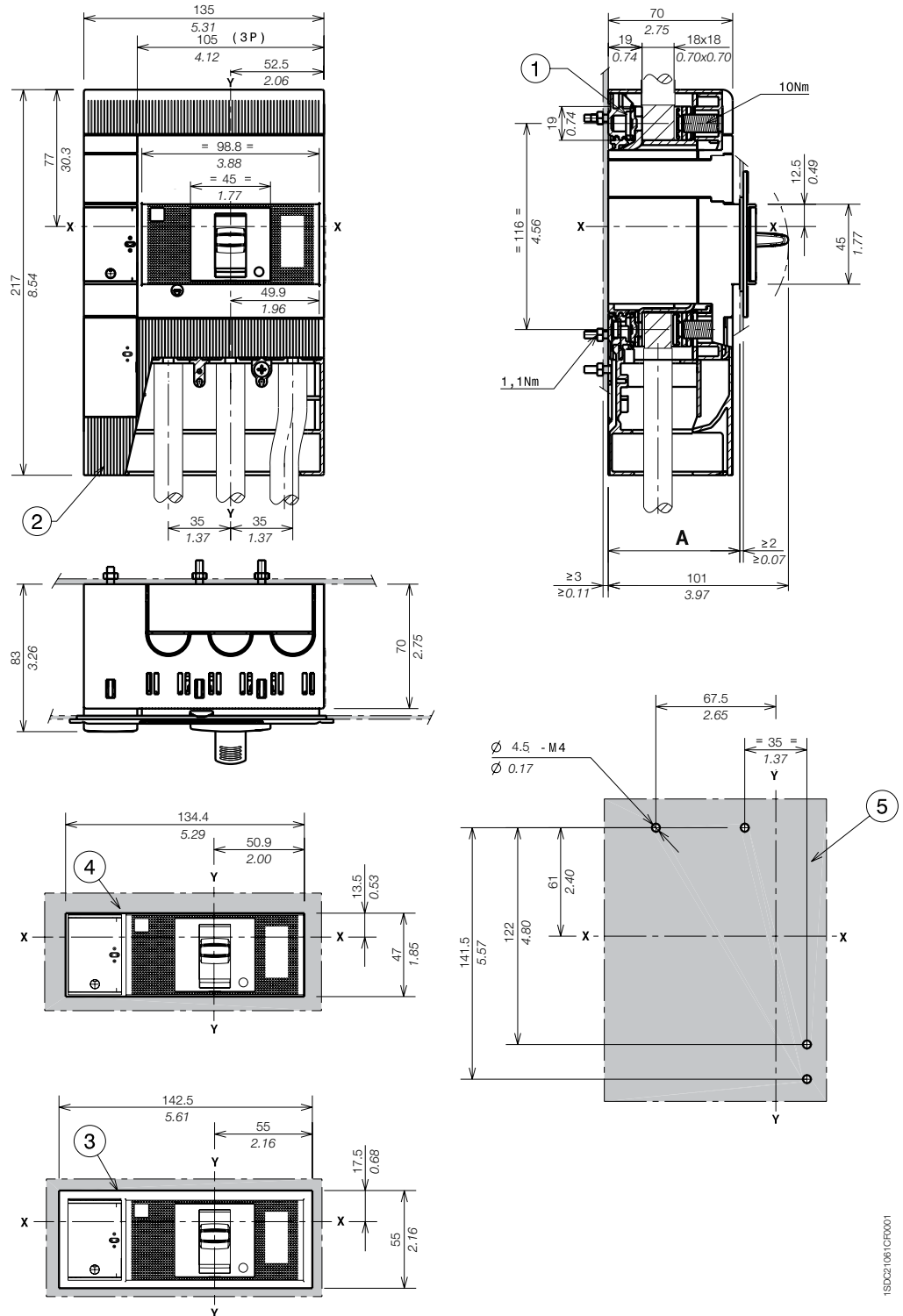

		A
With standard flange	III	74
Without flange	III	71

Overall dimensions

Tmax XT3 - Installation for plug-in circuit breaker

RC Inst and RC Sel residual current release for 4-pole circuit breaker

Captions

- ① Front terminals for cable connection
- ② Terminal covers with degree of protection IP40
- ③ Drilling template of door with direct rotary handle with flange
- ④ Drilling template of door with direct rotary handle without flange
- ⑤ Drilling template for mounting circuit breaker on sheet

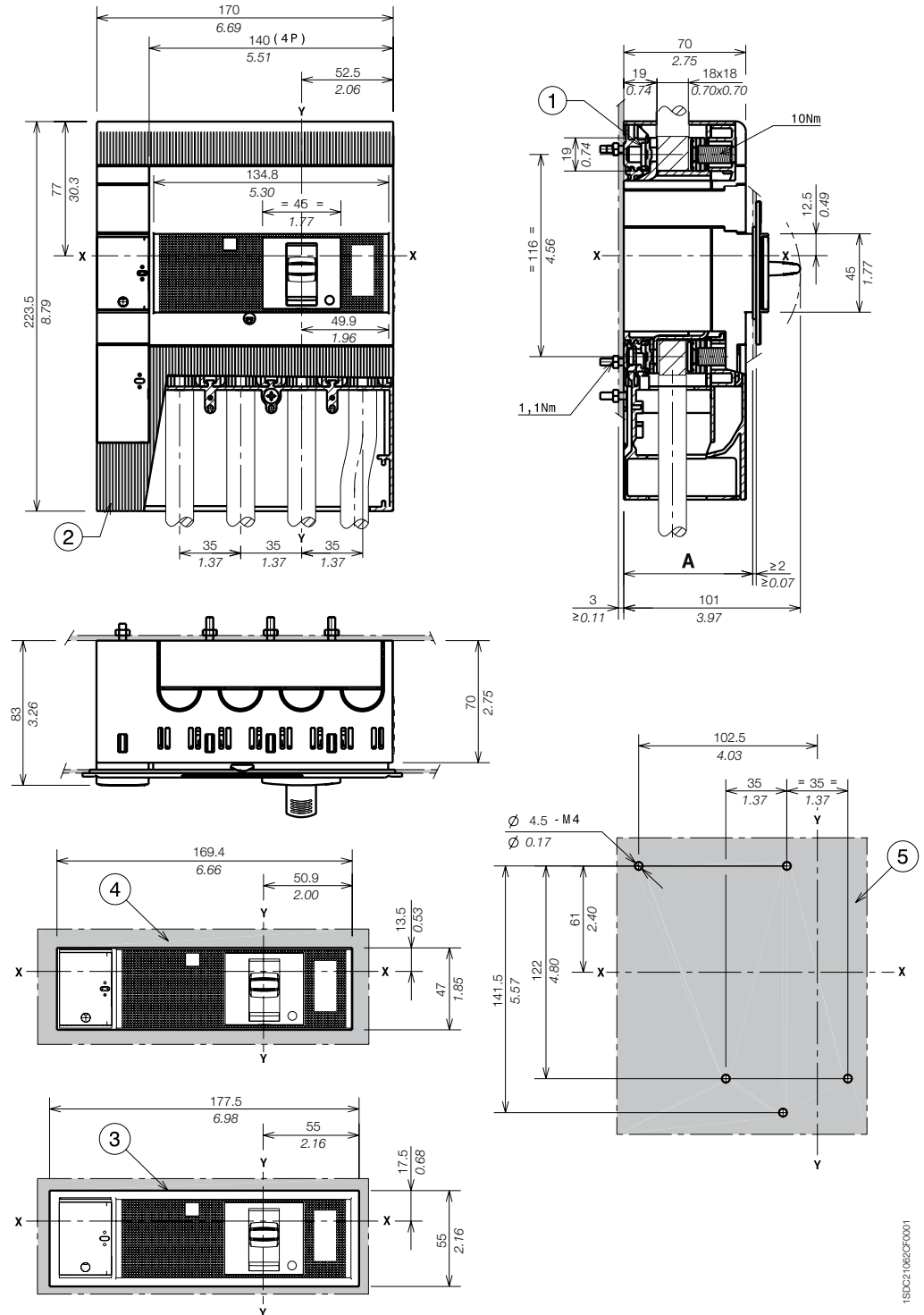

		A
With standard flange	IV	74
Without flange	IV	71

Mounting on the backplate

Captions

- ① Fixed part
- ② Moving part

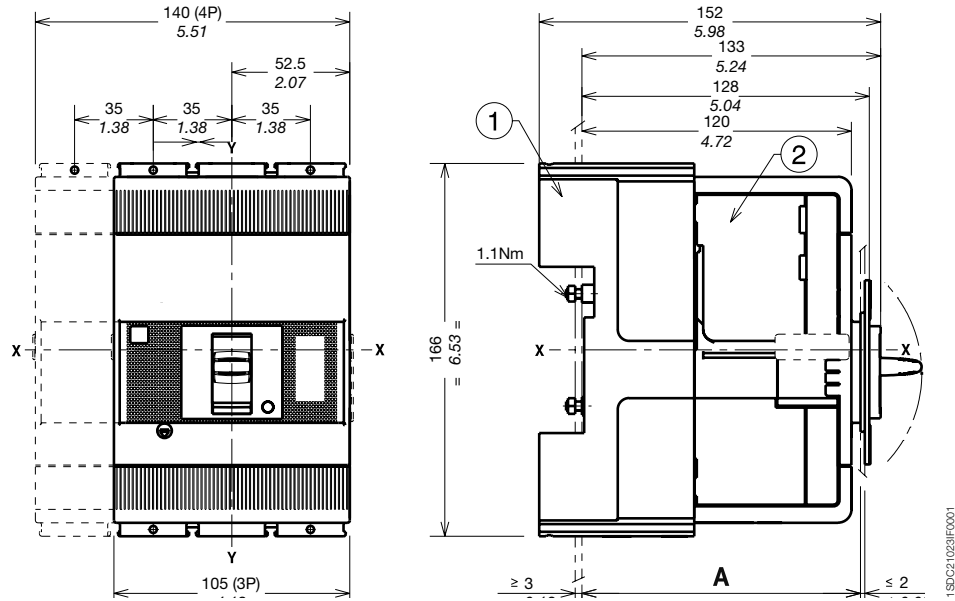

Mounting at 50mm		A
With standard flange	III - IV	124
Without flange	III - IV	121
	III - IV	129

Mounting at 70mm for extended front terminals		A
With standard flange	III - IV	144
Without flange	III - IV	141
	III - IV	149

Drilling templates for compartment door

With standard flange

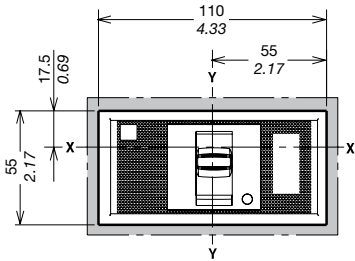

B=124 C=144
3 POLES

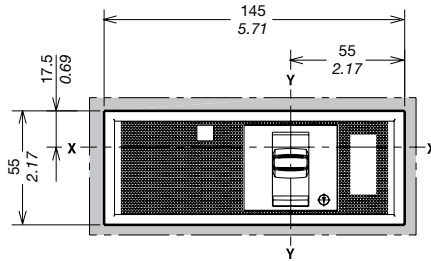

B=124 C=144
4 POLES

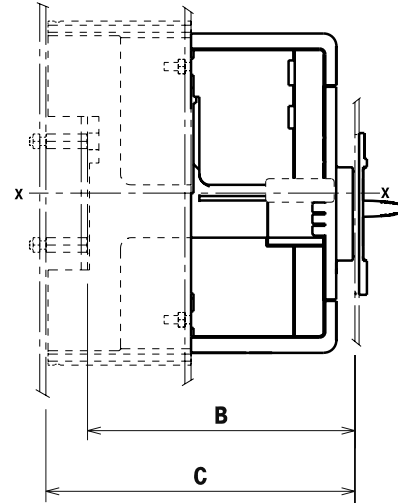

1SDXC21028F0001

Without flange

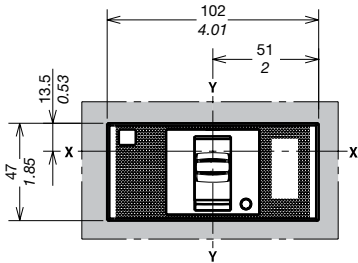

B=121 C=141
3 POLES

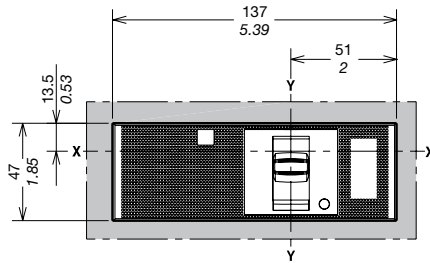

B=121 C=141
4 POLES

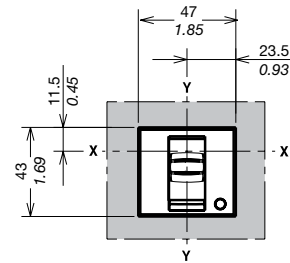

B=129 C=149
3-4 POLES

1SDXC21027F0001

With optional flange

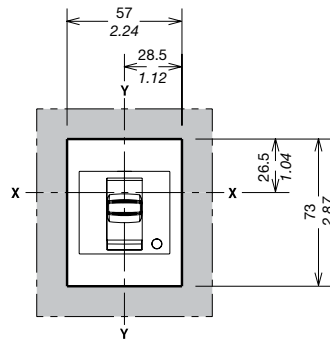

B=129 C=149
3-4 POLES

1SDXC21028F0001

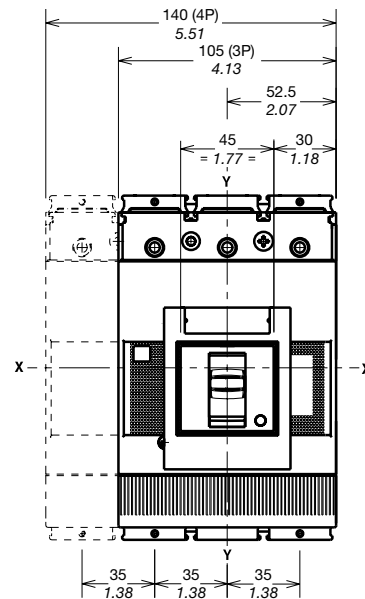

1SDXC21028F0001

Overall dimensions

Tmax XT3 - Terminals for plug-in circuit breaker

Terminals EF

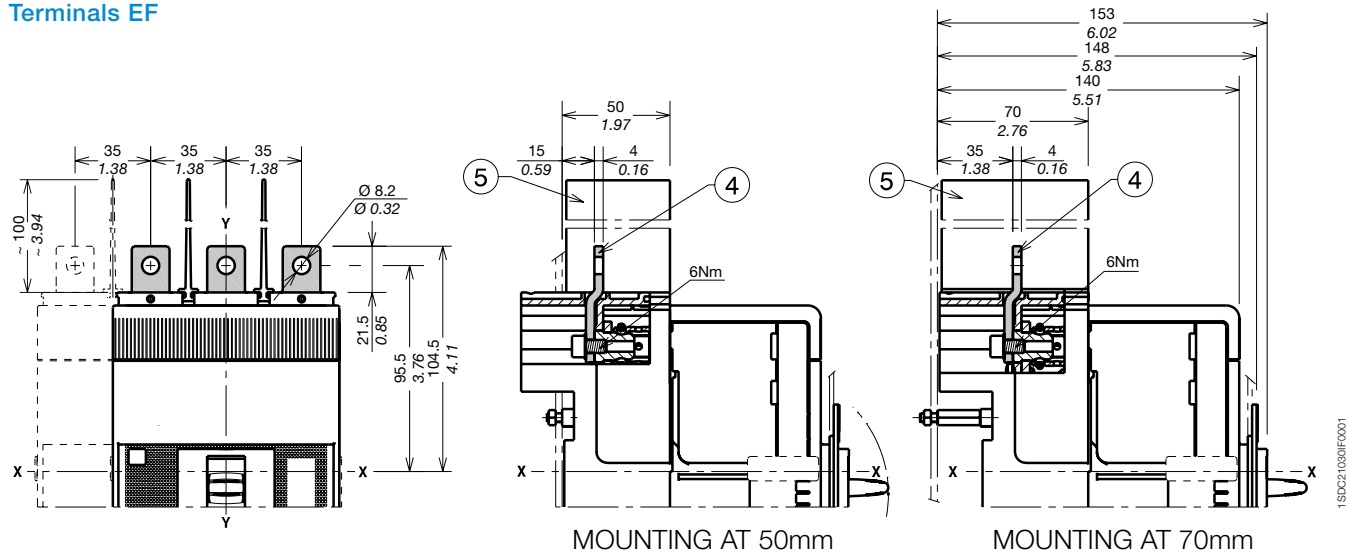

Captions

- ④ Front extended terminals
- ⑤ 100mm insulating barriers between phases (compulsory) provided

Terminals ES

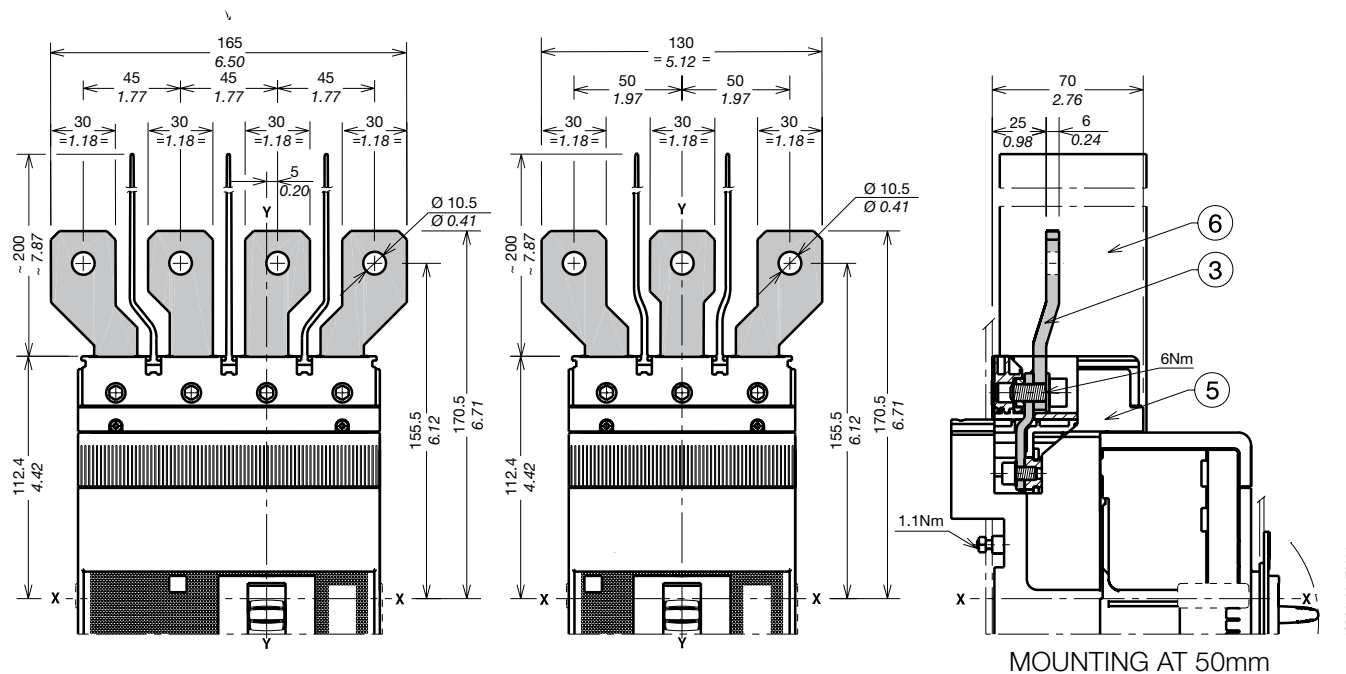

Captions

- ③ Front extended spread terminals for busbar connection
- ⑤ Adapter for fixed part (compulsory) not provided
- ⑥ 200mm insulating barriers between phases (compulsory) provided

1x2.5...50mm² terminals FCCuAl

Captions

- ① 1x90...185mm² front terminal FCCuAl
- ⑤ Adapter for fixed part (compulsory) not provided
- ⑥ 25mm insulating barriers between phases (compulsory) provided

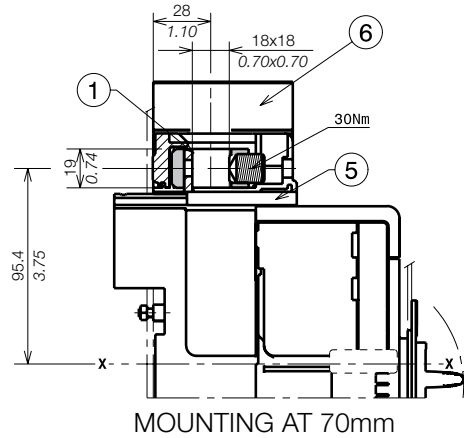
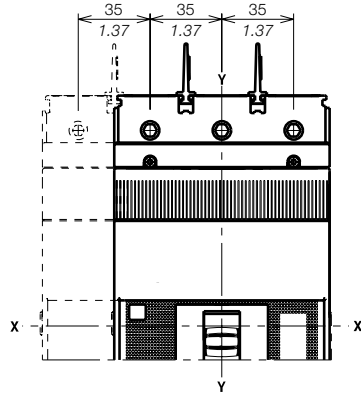

1SDC21069FF0001

Terminals FCCu

Captions

- ③ 25mm insulating barriers between phases (compulsory) provided as standard with the circuit breaker
- ⑥ Terminals FCCu

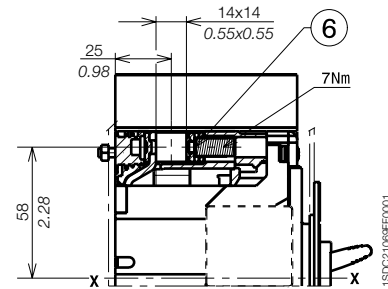
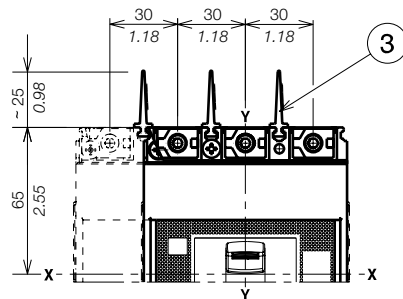

1SDC21069FF0001

Terminals MC

Caption

- ⑥ Multi-cable terminals

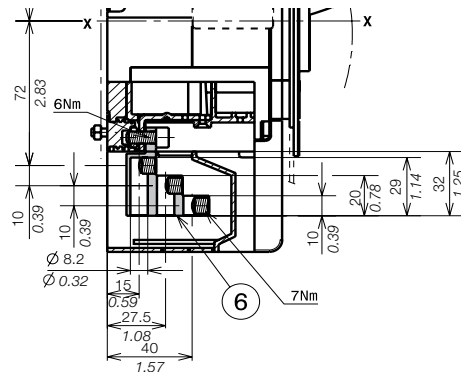
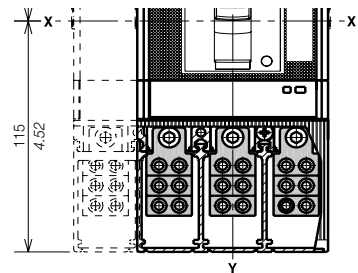

1SDC21069FF0001

Overall dimensions

Tmax XT3 - Terminals for plug-in circuit breaker

Terminals HR/VR

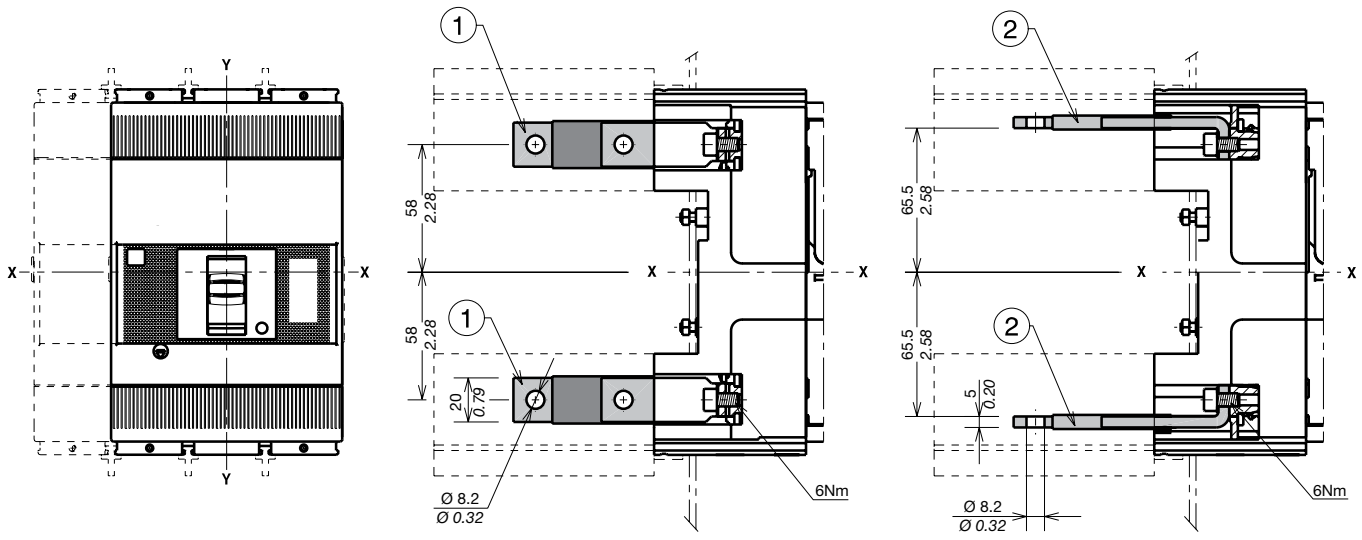

Captions

- ① Rear vertical terminals
- ② Rear horizontal terminals
- ③ 90mm insulating barriers between phases (compulsory not provided)

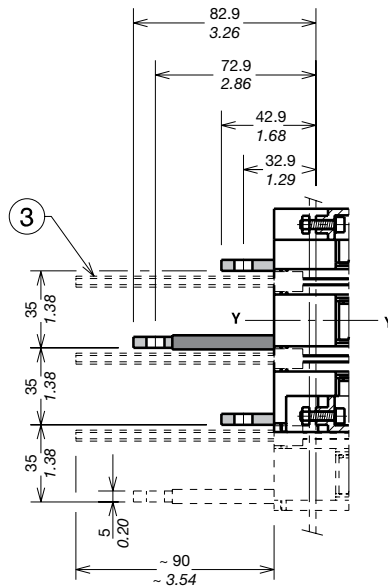

MOUNTING AT 50mm

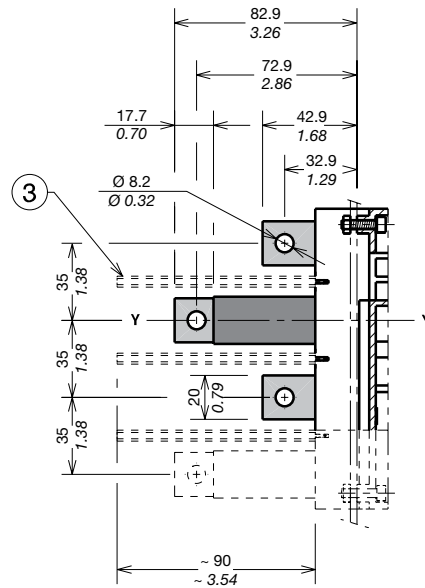

MOUNTING AT 50mm

1SDQ210421F0001

Overall dimensions

Tmax XT3 - Accessories for plug-in circuit breaker

Direct motor operator (MOD)

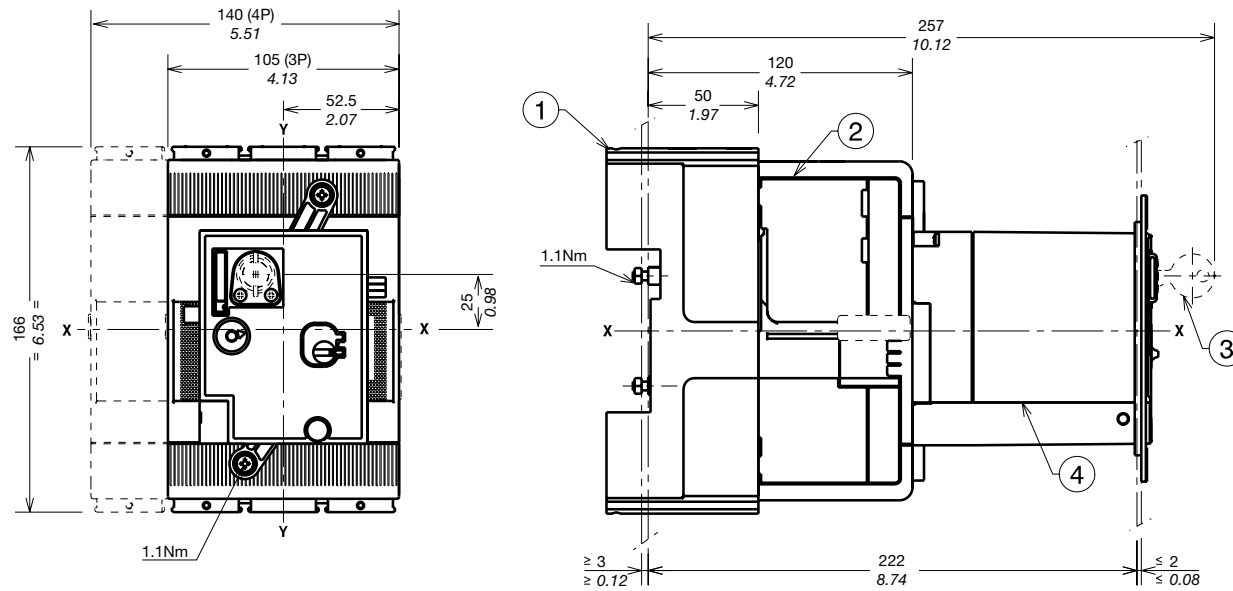

MOUNTING AT 50mm

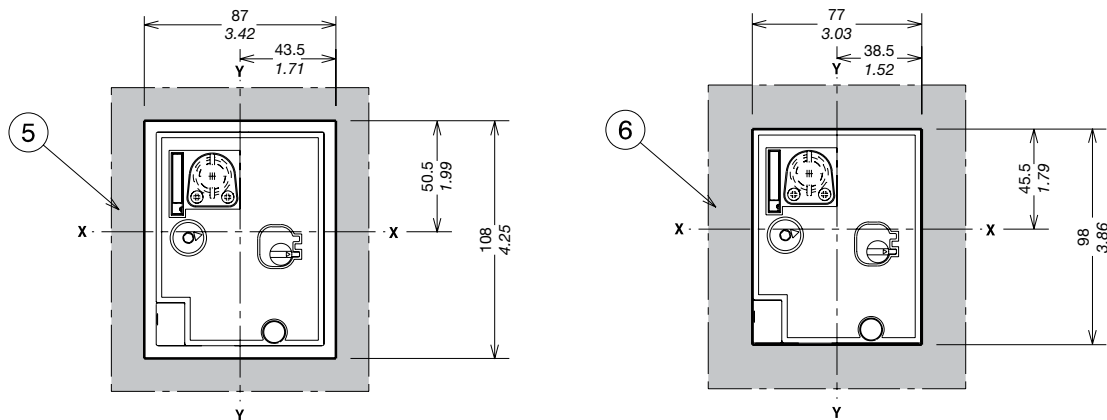

Captions

- ① Fixed part
- ② Moving part
- ③ Key lock (not supplied)
- ④ Direct motor operator MOD
- ⑤ Drilling template of door with MOD with flange
- ⑥ Drilling template of door with MOD without flange

Overall dimensions

Tmax XT4 - Installation for fixed circuit breaker

Mounting on the backplate

Captions

- ① Insulating plate compulsory
- ② Overall dimension of optional wiring ducts
- ③ 25mm insulating barriers between phases (compulsory) provided
- ④ Front carter compulsory for through door of the panel $\leq 25\text{mm}/0,98''$

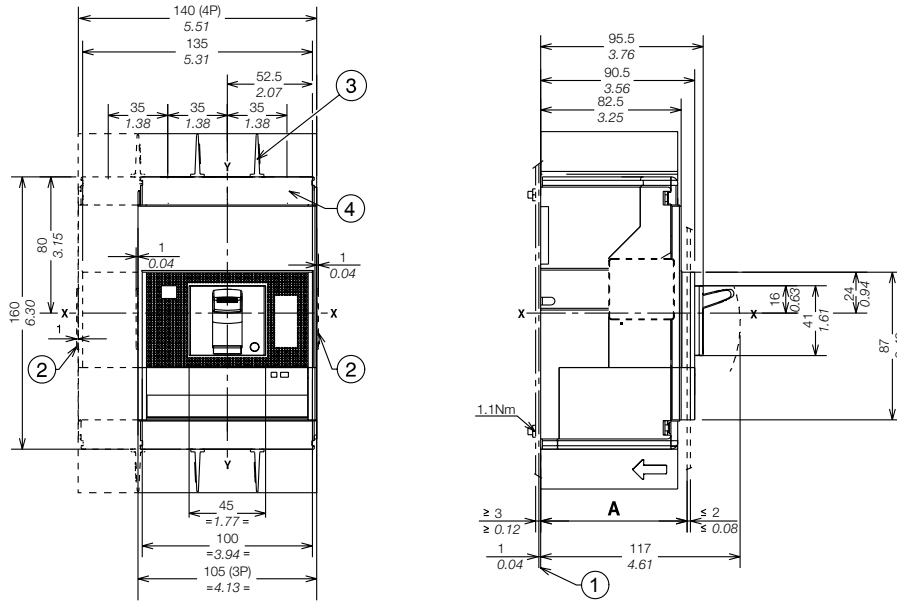

		A
With standard flange	III - IV	86
Without flange	III - IV	83.5
	III - IV	91.5

Mounting on DIN 50022 rail

Captions

- ① Mounting bracket
- ③ 25mm insulating barriers between phases (compulsory) provided

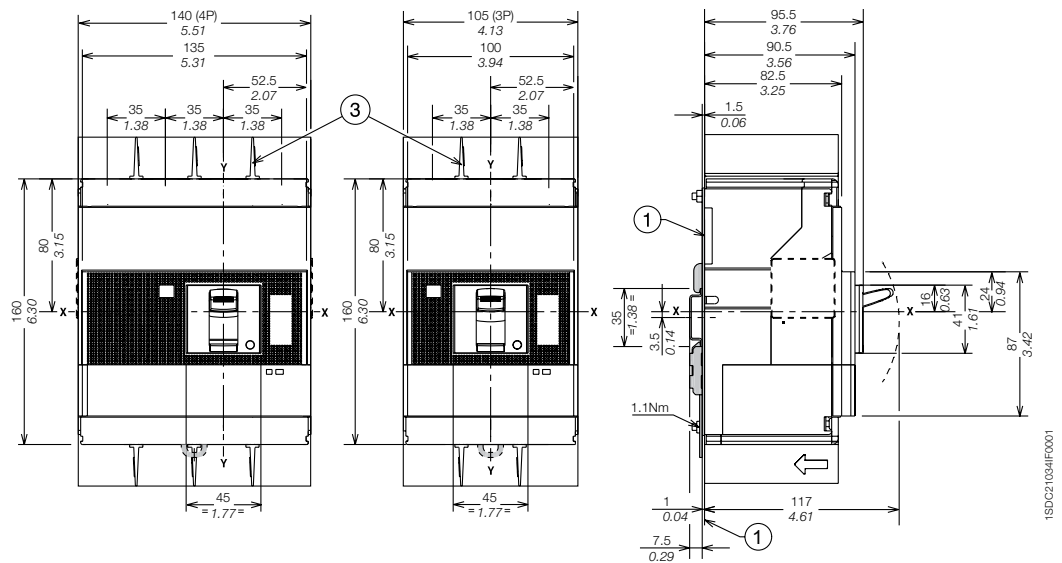

Drilling templates for the backplate

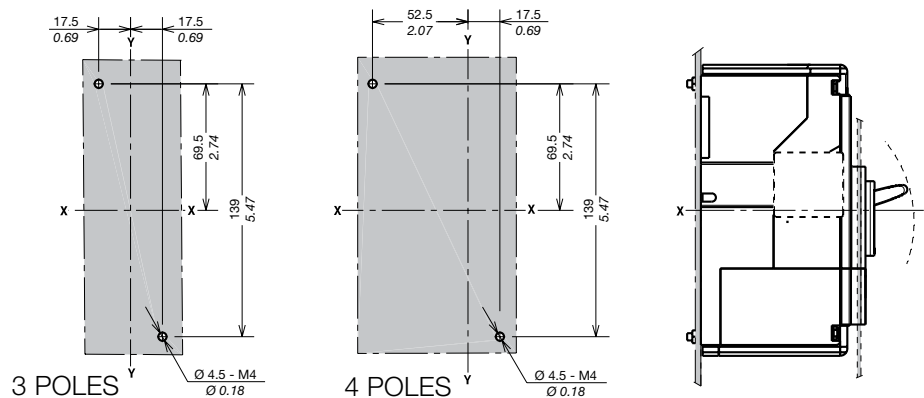

Flanges

Captions

- ① Flange for fixed circuit breaker III
- ② Flange for fixed circuit breaker IV
- ③ Flange for fixed circuit breaker III-IV with MOE and FLD
- ④ Flange for circuit breaker III-IV with direct rotary handle RHD
- ⑤ Optional flange

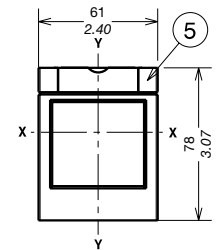
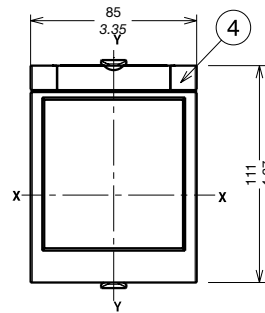
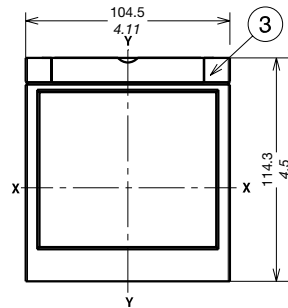
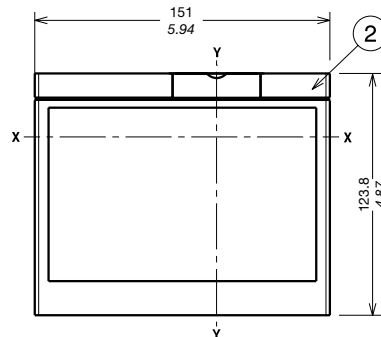
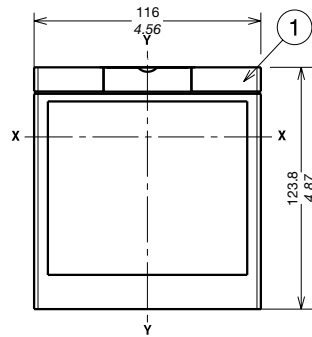

1SDC210381FC001

Overall dimensions

Tmax XT4 - Installation for fixed circuit breaker

Drilling templates for compartment door

With standard flange

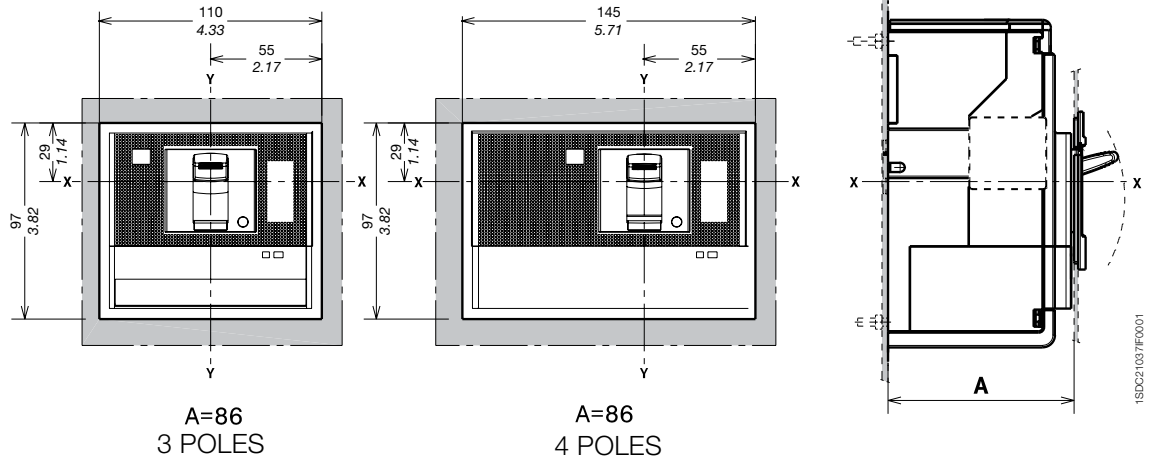

Without flange

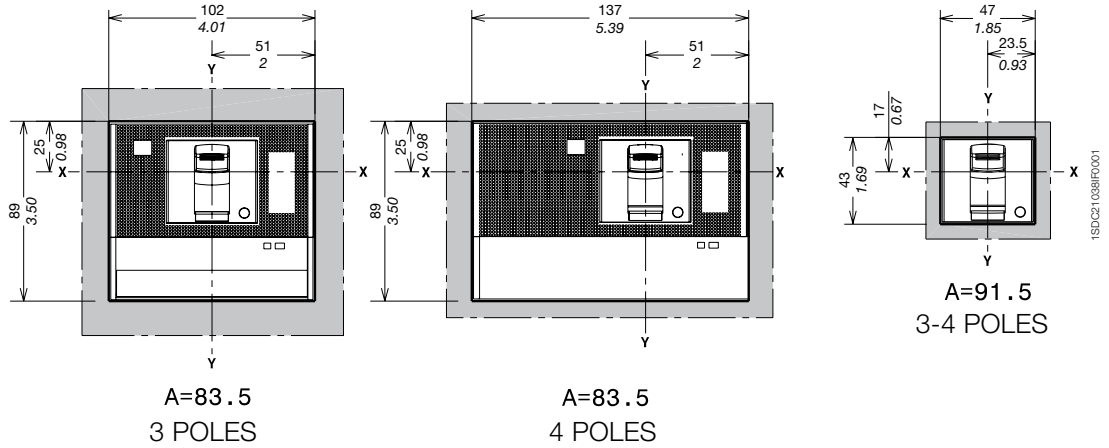

With optional flange

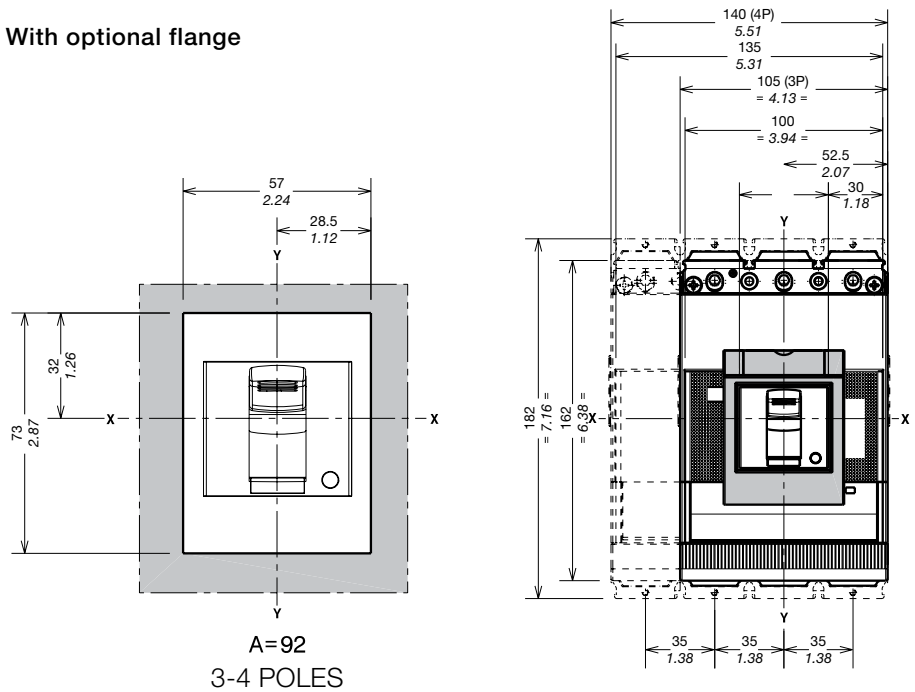

Overall dimensions

Tmax XT4 - Terminals for fixed circuit breaker

Terminals F

Captions

- ① 25mm insulating barriers between phases (compulsory) provided
- ② Top terminal covers with degree of protection IP30 (optional) not provided

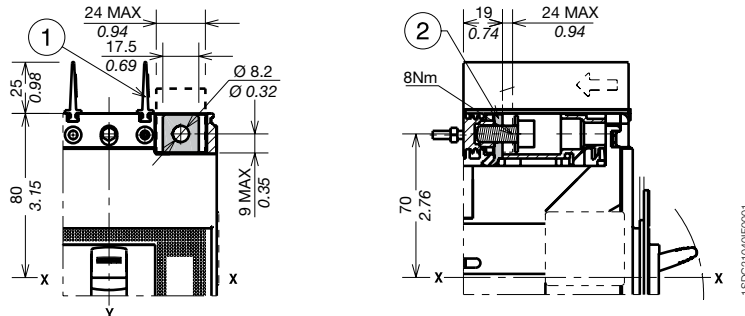

Terminals EF

Captions

- ③ Front extended terminals
- ④ Terminal covers with degree of protection IP40 (optional) not provided
- ⑤ 100mm insulating barriers between phases (compulsory) provided
- ⑥ Insulated plate provided compulsory for $U_e > 440V$
- ⑦ Drilling template for 3p circuit breaker
- ⑧ Drilling template for 4p circuit breaker

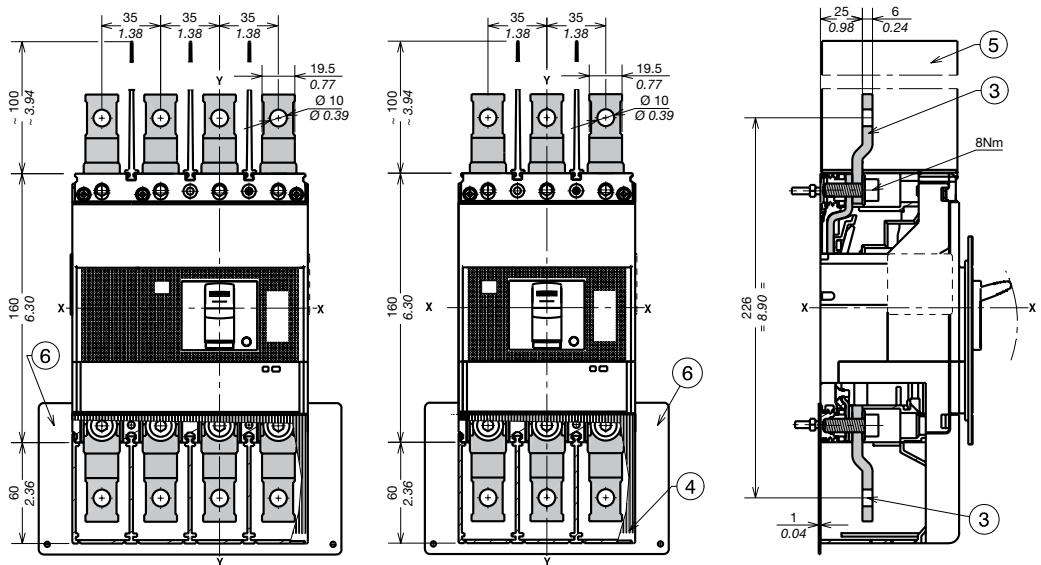

3 POLES

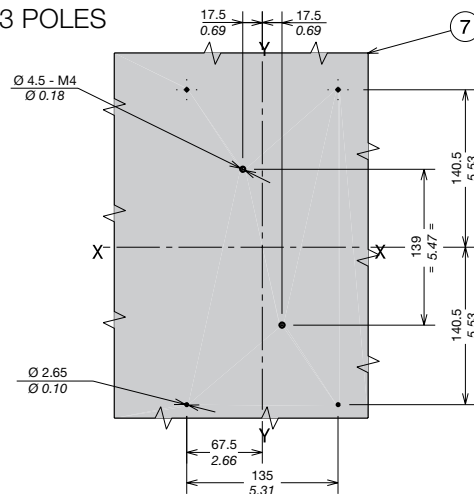

4 POLES

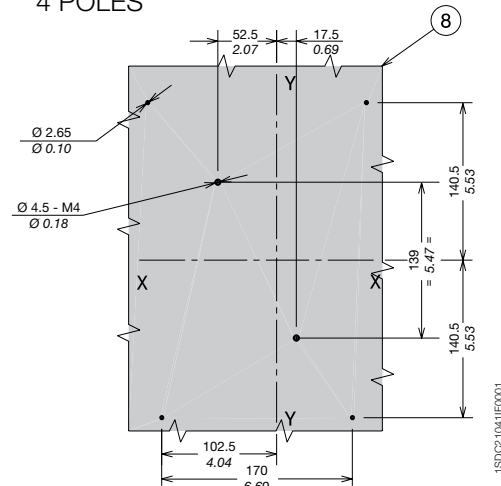

Overall dimensions

Tmax XT4 - Terminals for fixed circuit breaker

Terminals ES

Captions

- ① Drilling template for 3p circuit breaker
- ② Drilling template for 4p circuit breaker
- ③ Front extended spread terminals
- ④ 200mm insulating barriers between phases (compulsory) provided
- ⑤ Insulated plate provided compulsory for $U_e > 440V$

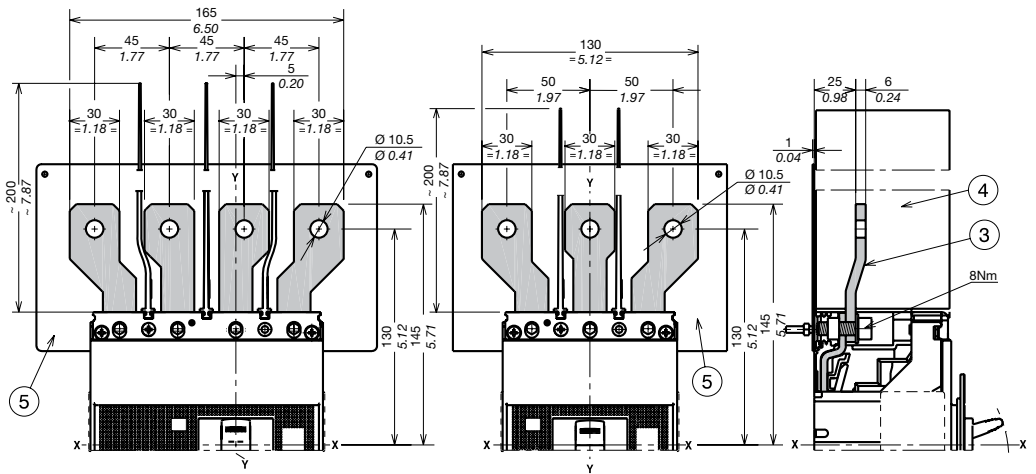

3 POLES

4 POLES

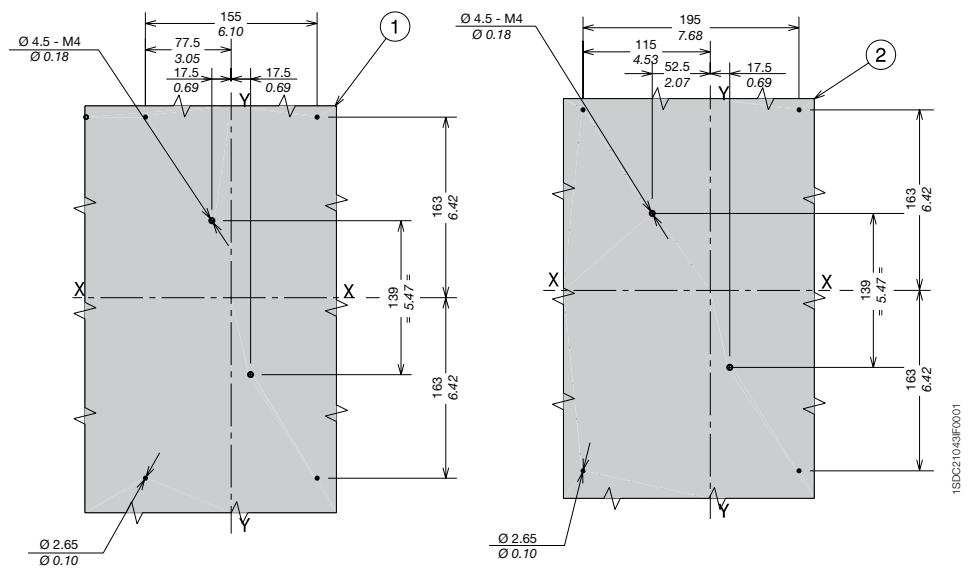

1x2,5...50mm² terminals FCCuAl

Captions

- ① 1x2,5...50mm² terminals FCCuAl
- ③ 25mm insulating barriers between phases (compulsory) provided

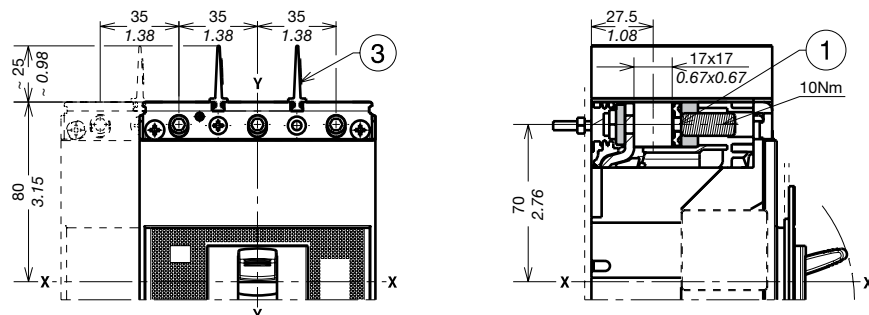

2x35...150mm² terminals FCCuAl

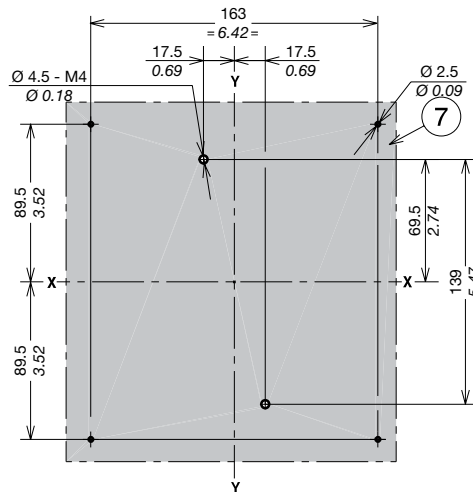
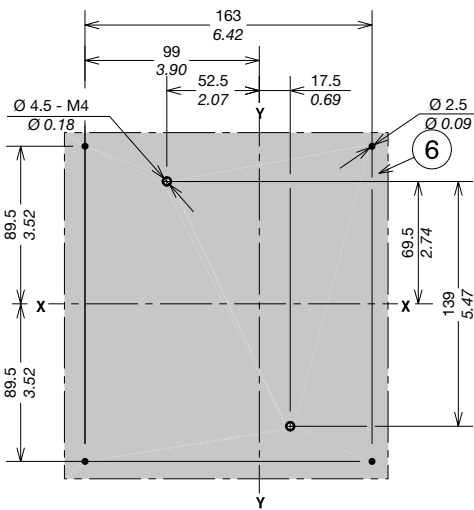
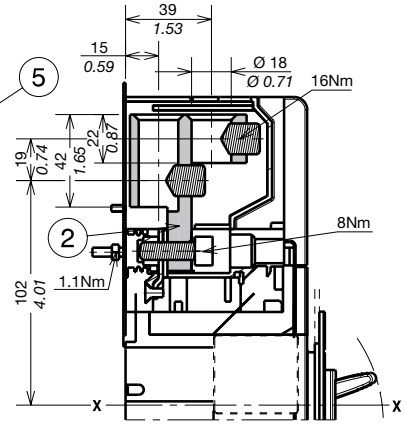
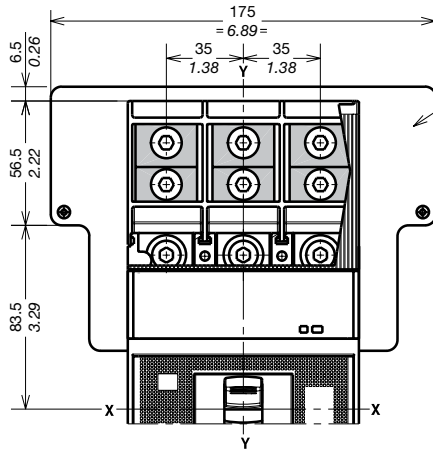
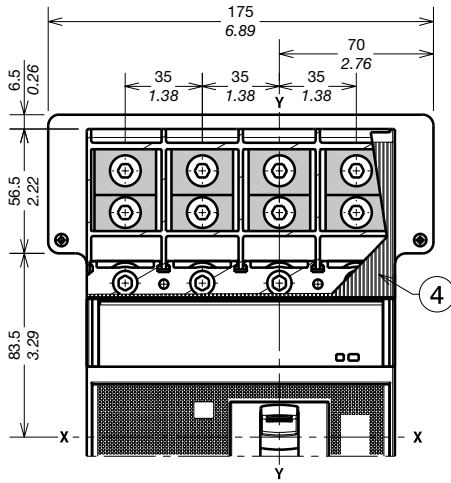

1SDC21046 F0001

Captions

- ② 2x35...150mm² terminals FCCuAl
- ④ Terminal covers with degree of protection IP40 (optional) provided
- ⑤ Provided rear insulated plate (compulsory for CuAl 2x150mm² cables)
- ⑥ Drilling template for mounting circuit breaker IV with insulating plate
- ⑦ Drilling template for mounting circuit breaker III with insulating plate

Overall dimensions

Tmax XT4 - Terminals for fixed circuit breaker

Terminals FCCu

Captions

- ① Terminals FCCu
- ④ 25mm insulating barriers between phases (compulsory provided as standard with the circuit breaker)

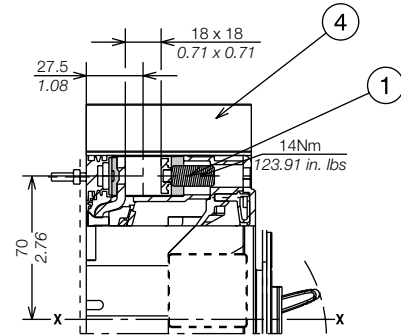
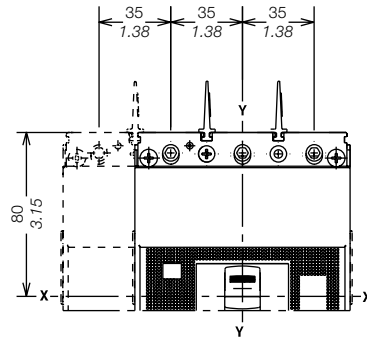

1SDC21046F0001

Terminals MC

Captions

- ② Multi-cable terminals
- ③ Terminal covers with degree of protection IP40 (optional provided)

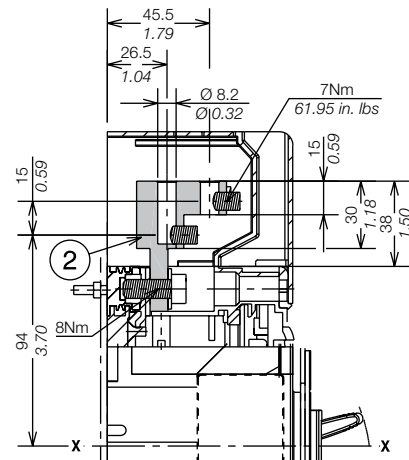
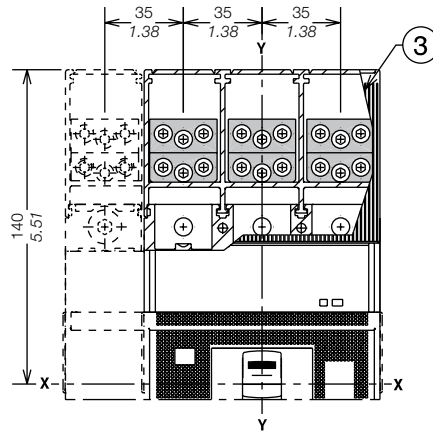

1SDC21047F0001

Overall dimensions

Tmax XT4 - Accessories for fixed circuit breaker

Rotary handle operating mechanism of the compartment door (RHE)

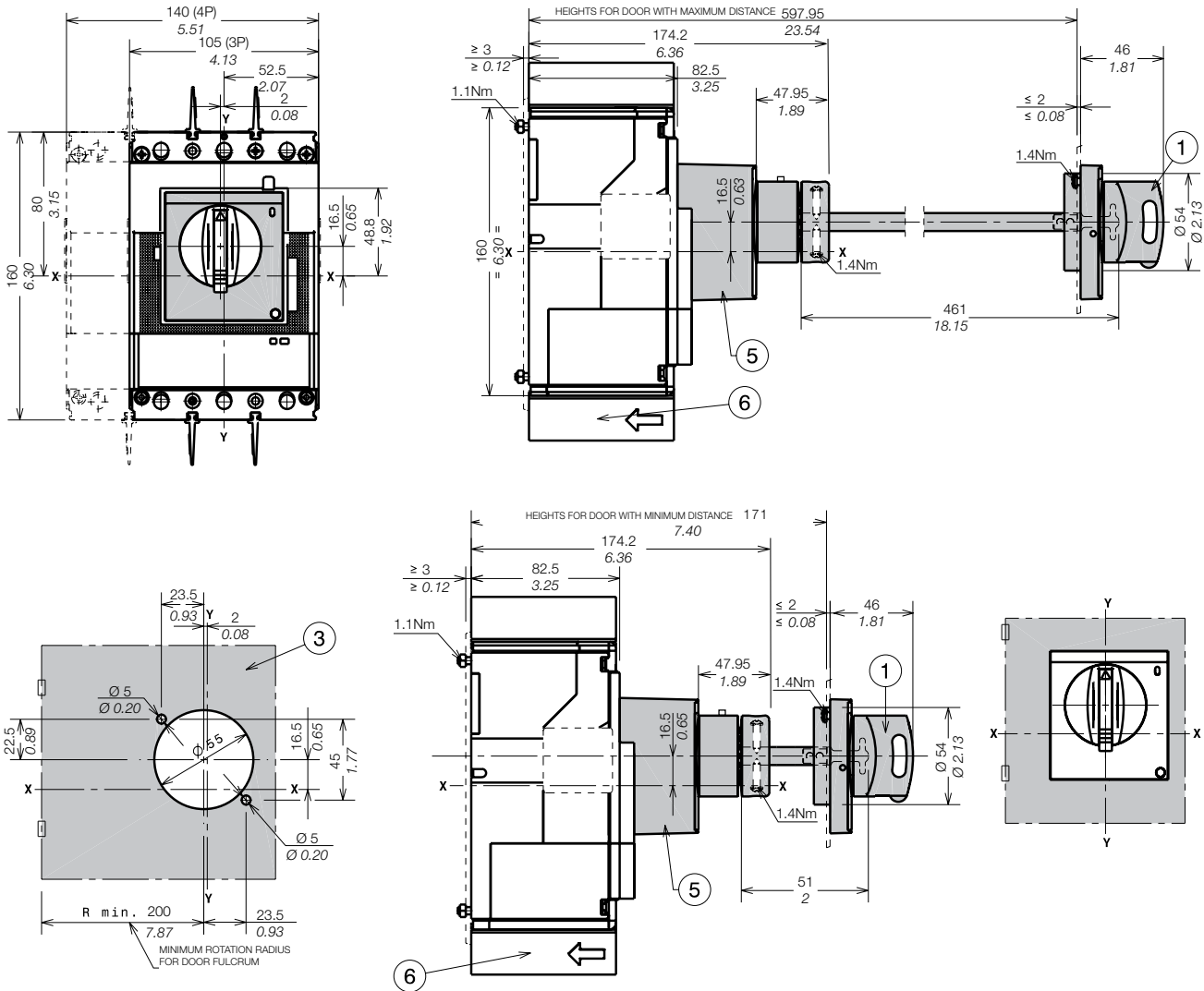

Captions

- ① Rotary handle operating mechanism of the compartment door
- ③ Drilling template for RHE
- ⑤ Transmission unit
- ⑥ 25mm insulating barriers between phases

Stored energy motor operator (MOE)

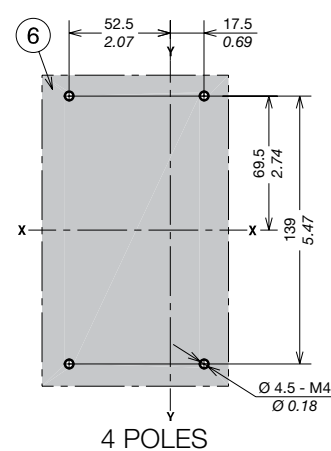
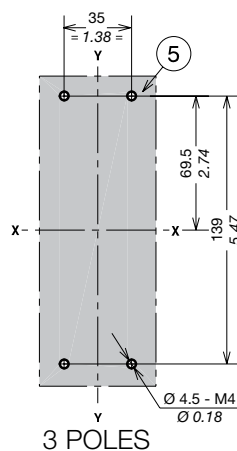
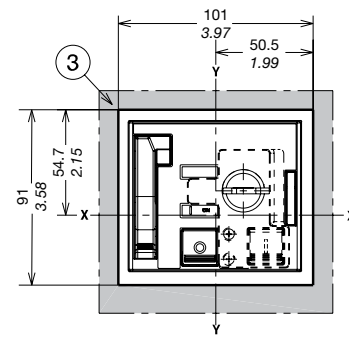
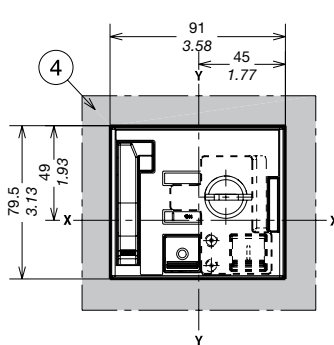
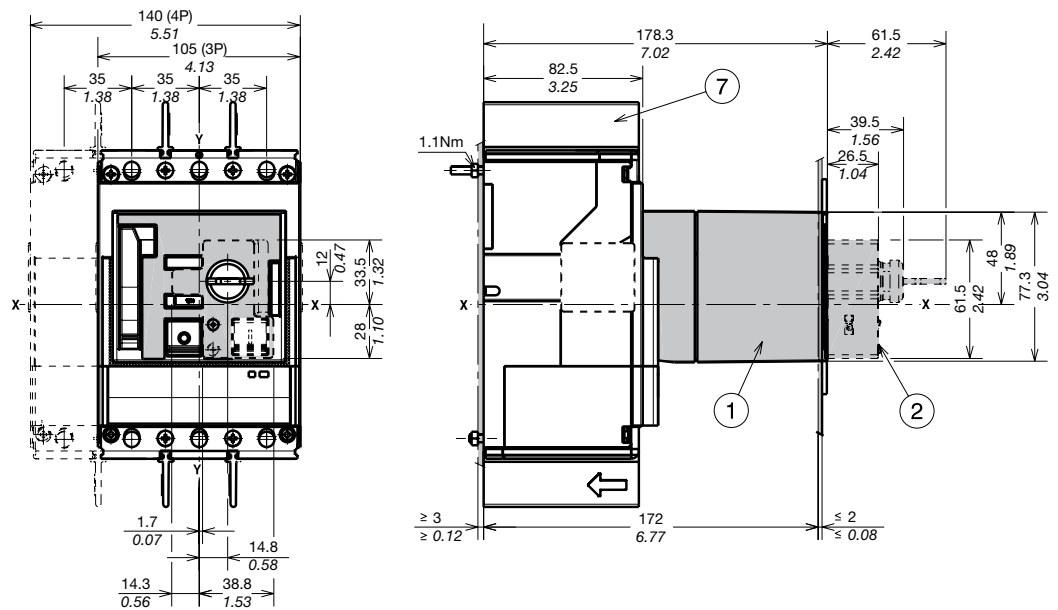

Captions

- ① Stored energy motor operator (MOE)
- ② Key lock (not provided)
- ③ Drilling template of door with direct rotary handle with flange (MOE)
- ④ Drilling template of door with direct rotary handle without flange (MOE)
- ⑤ Drilling template for mounting circuit breaker III on the backplate
- ⑥ Drilling template for mounting circuit breaker IV on the backplate
- ⑦ 25mm insulating barriers between phases

Overall dimensions

Tmax XT4 - Accessories for fixed circuit breaker

Front for lever operating mechanism (FLD)

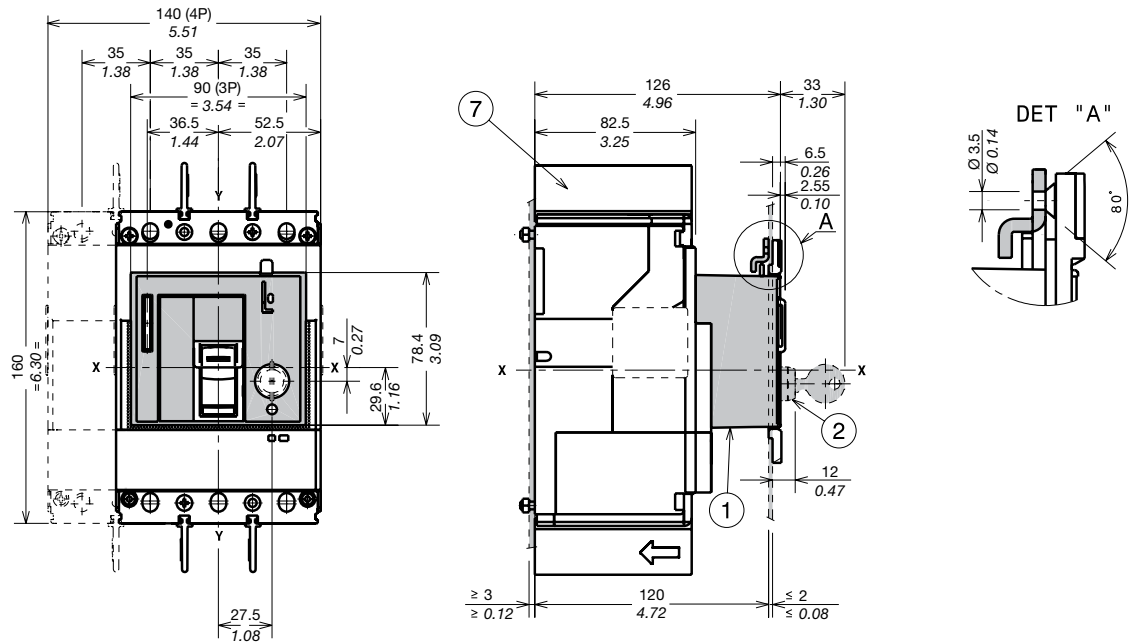

Captions

- ① Front for lever operating mechanism (FLD)
- ② Key lock (not provided)
- ③ Drilling template of door with direct rotary handle with flange (FLD)
- ④ Drilling template of door with direct rotary handle without flange (FLD)
- ⑤ Drilling template for mounting circuit breaker III on the backplate
- ⑥ Drilling template for mounting circuit breaker IV on the backplate
- ⑦ 25mm insulating barriers between phases

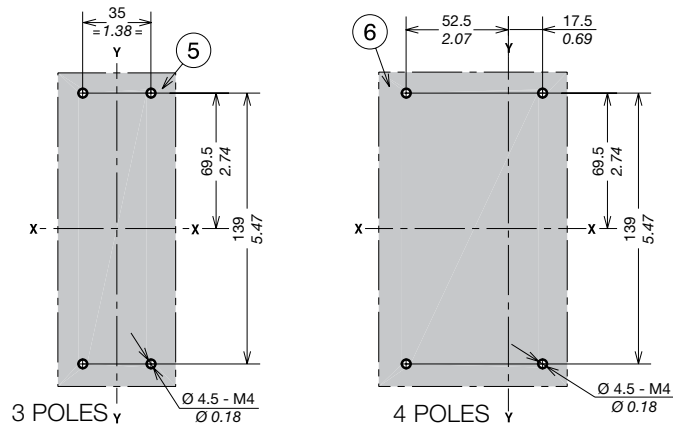

1SD021051 F0001

Ekip Display or LED Meter

Captions

- ① Ekip Display or LED Meter
- ② Optional wiring ducts
- ③ 25mm insulating barriers between phases

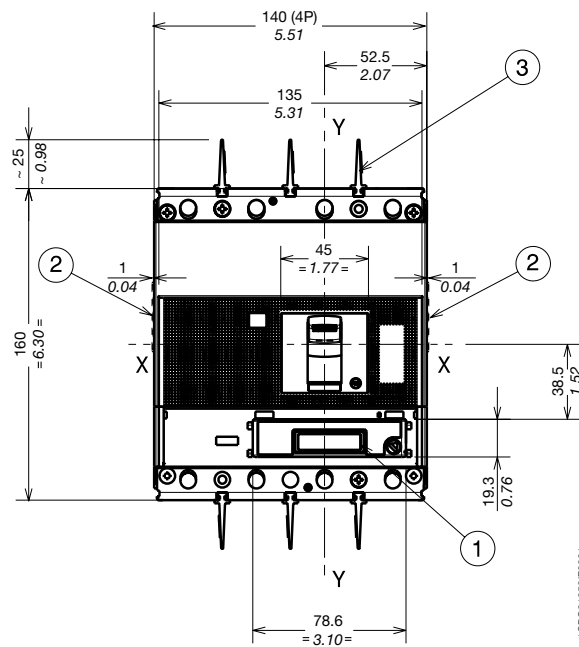
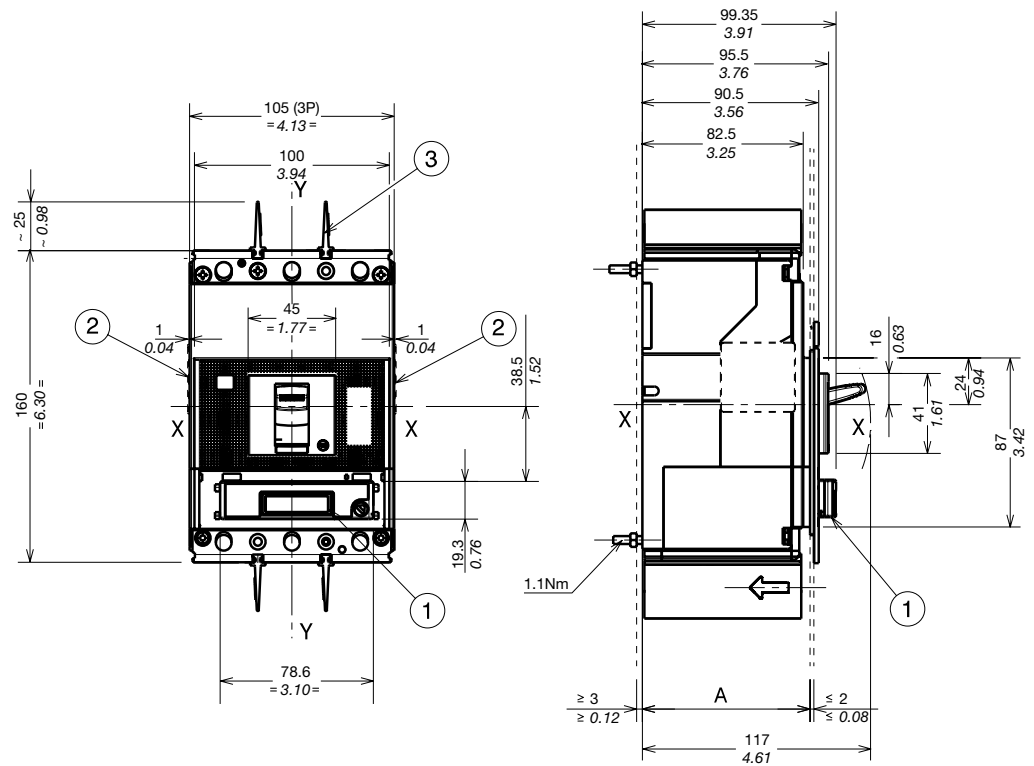

Overall dimensions

Tmax XT4 - Accessories for fixed circuit breaker

Residual current RC Sel

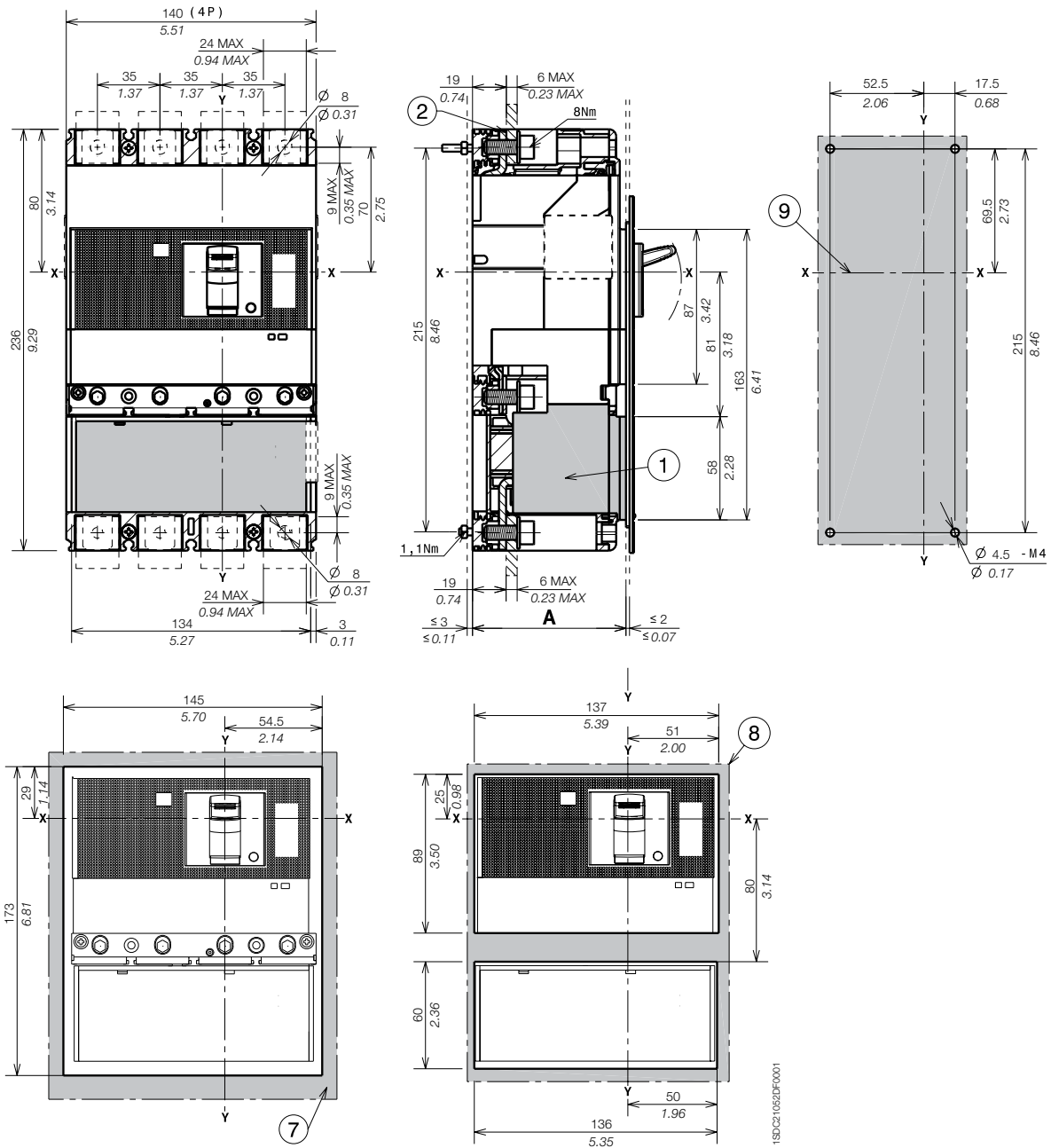

Captions

- ① Residual current
- ② Front terminals
- ⑦ Drilling template of door with direct rotary handle and mounting with flange
- ⑧ Drilling template of door with direct rotary handle and mounting without flange
- ⑨ Drilling template for mounting circuit breaker on sheet

		A
With standard flange	IV	86
Without flange	IV	83.5

Overall dimensions

Tmax XT4 - Installation for plug-in circuit breaker

Mounting on the backplate

Captions

- ① Fixed part
- ② Moving part

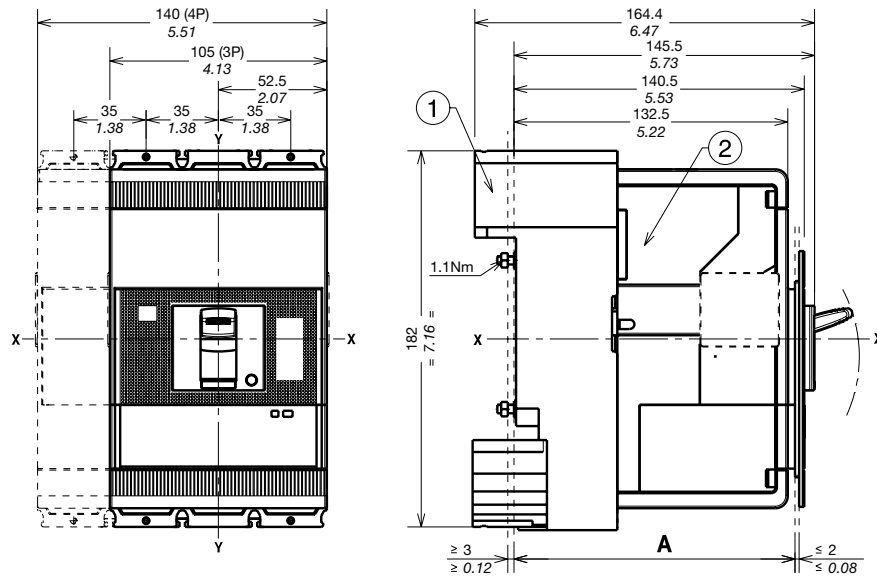

Mounting at 50mm		A
With standard flange	III - IV	136
Without flange	III - IV	133.5
	III - IV	141.5

Mounting at 70mm for front extended terminals		A
With standard flange	III - IV	156
Without flange	III - IV	153.5
	III - IV	161.5

Overall dimensions

Tmax XT4 - Installation for plug-in circuit breaker

Drilling templates

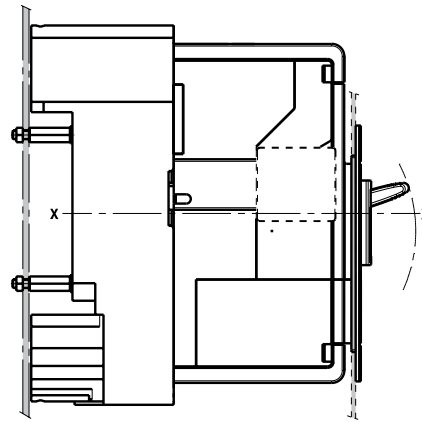
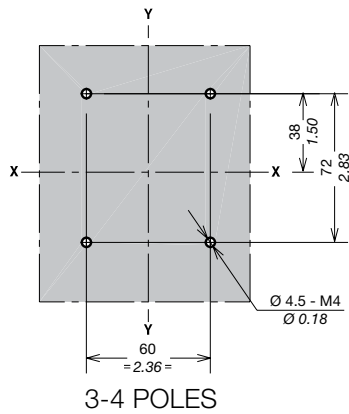
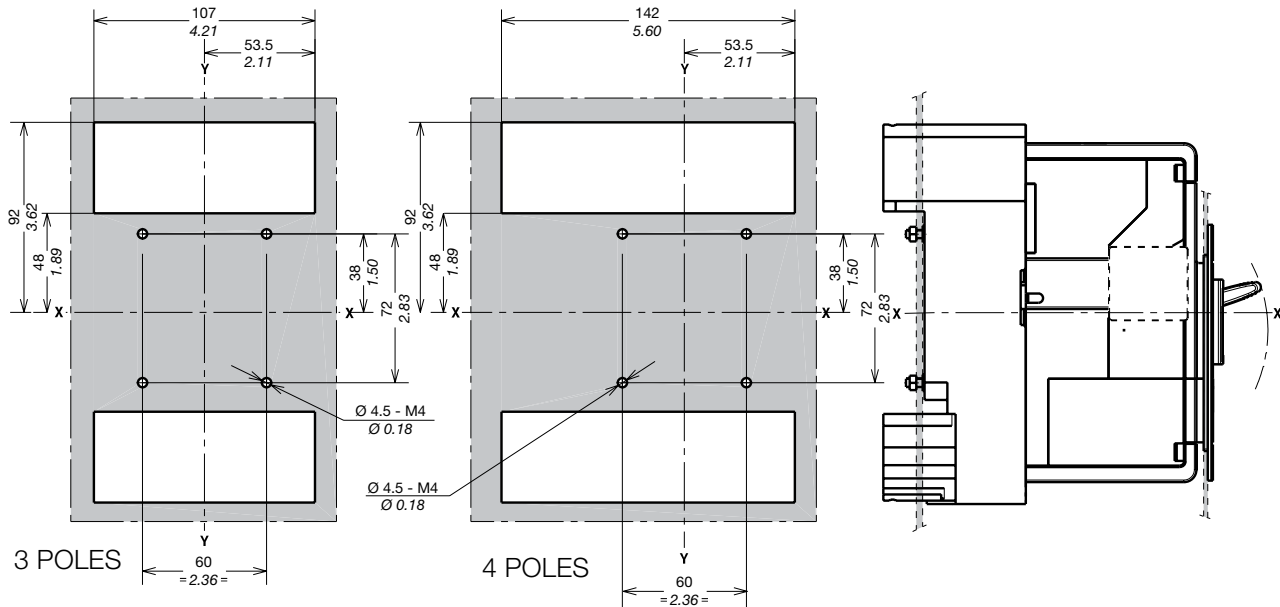

Flanges

Captions

- ① Flange for plug-in circuit breaker III
- ② Flange for plug-in circuit breaker IV
- ③ Flange for plug-in circuit breaker III-IV with MOE and FLD
- ④ Flange for circuit breaker III-IV with direct rotary handle
- ⑤ Optional flange

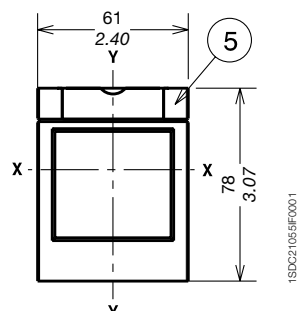
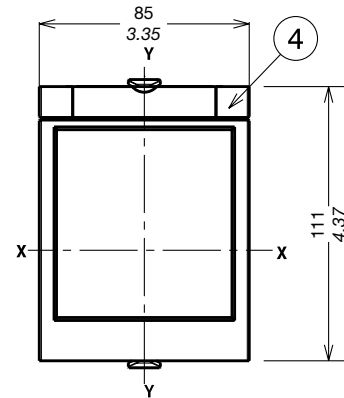
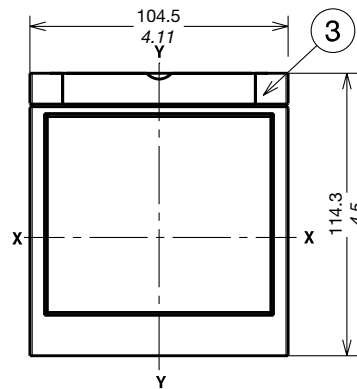
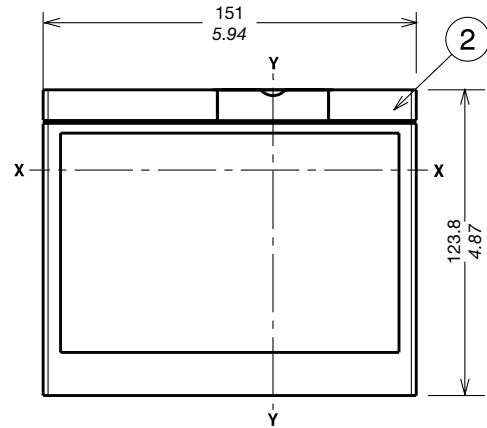
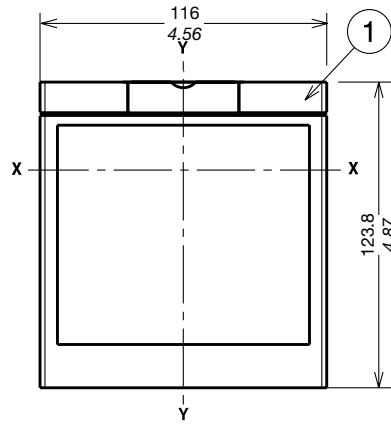

Overall dimensions

Tmax XT4 - Installation for plug-in circuit breaker

Drilling templates compartment door

With standard flange

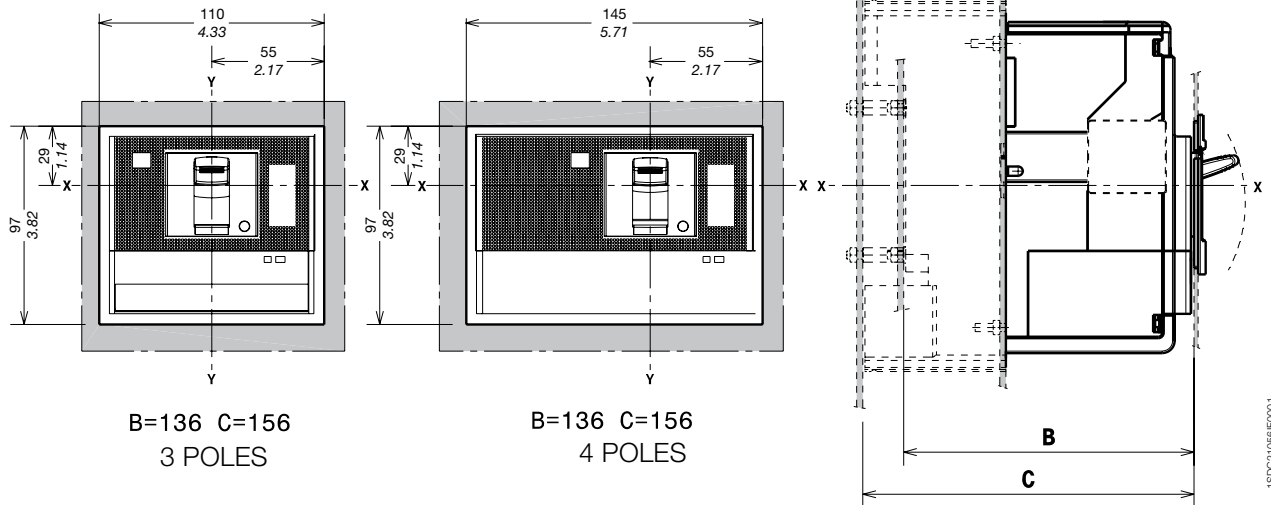

B=136 C=156
3 POLES

B=136 C=156
4 POLES

Without flange

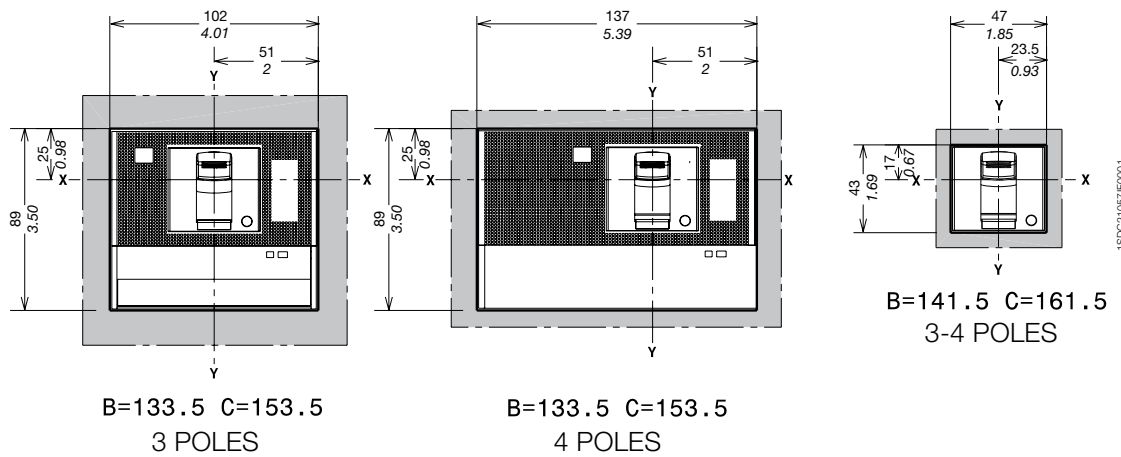

B=133.5 C=153.5
3 POLES

B=133.5 C=153.5
4 POLES

B=141.5 C=161.5
3-4 POLES

With optional flange

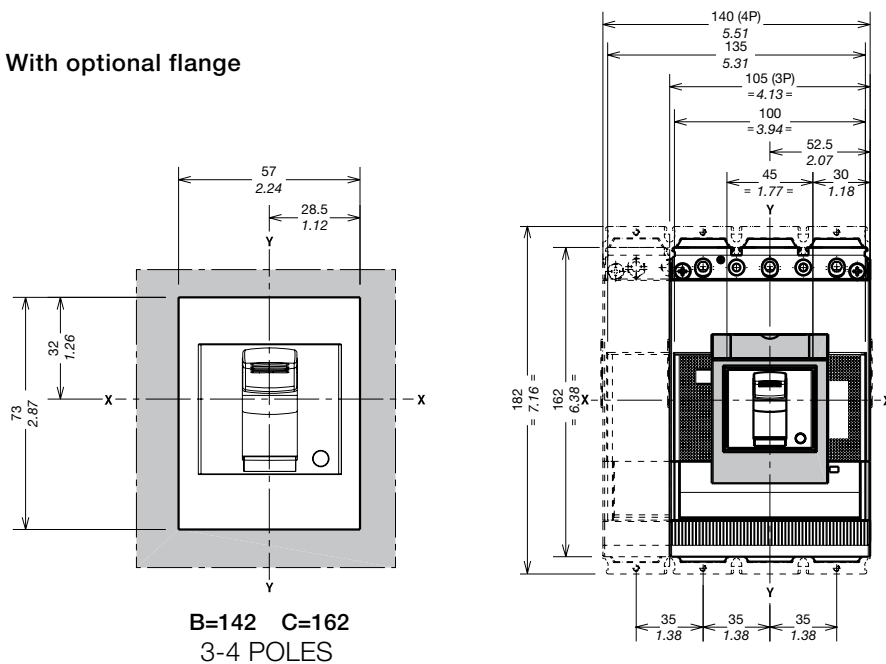

B=142 C=162
3-4 POLES

Overall dimensions

Tmax XT4 - Terminals for plug-in circuit breaker

Terminals EF

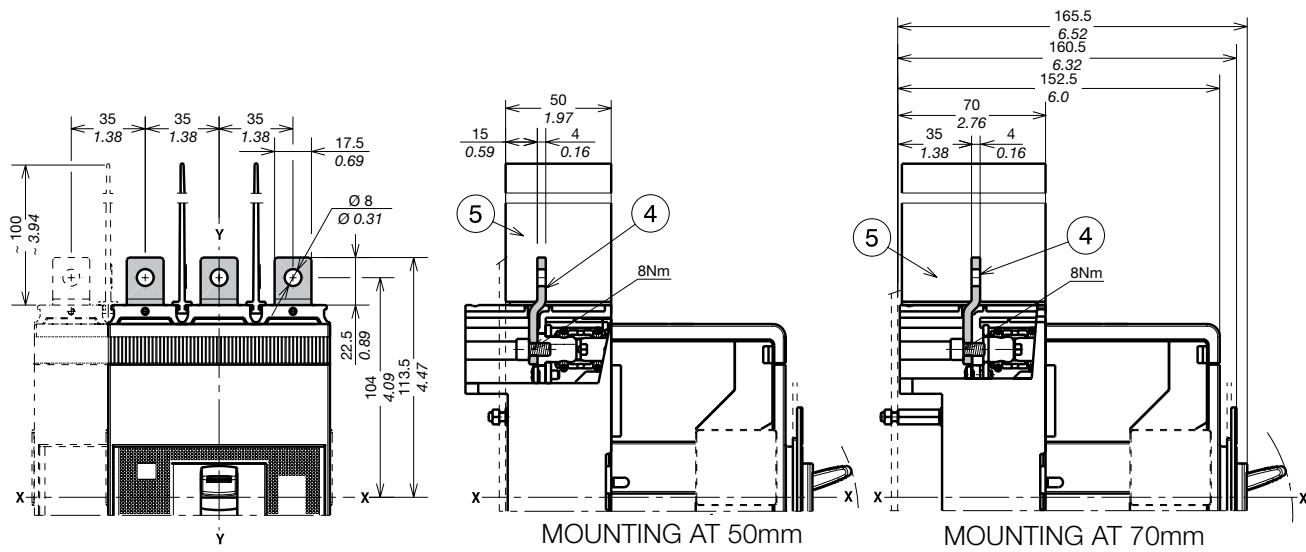

Captions

- ④ Front extended terminals
- ⑤ 100mm insulating barriers between phases (compulsory) provided

Note: insulated plate to be provided by customer

1SDC211099R001

Overall dimensions

Tmax XT4 - Terminals for plug-in circuit breaker

Terminals ES

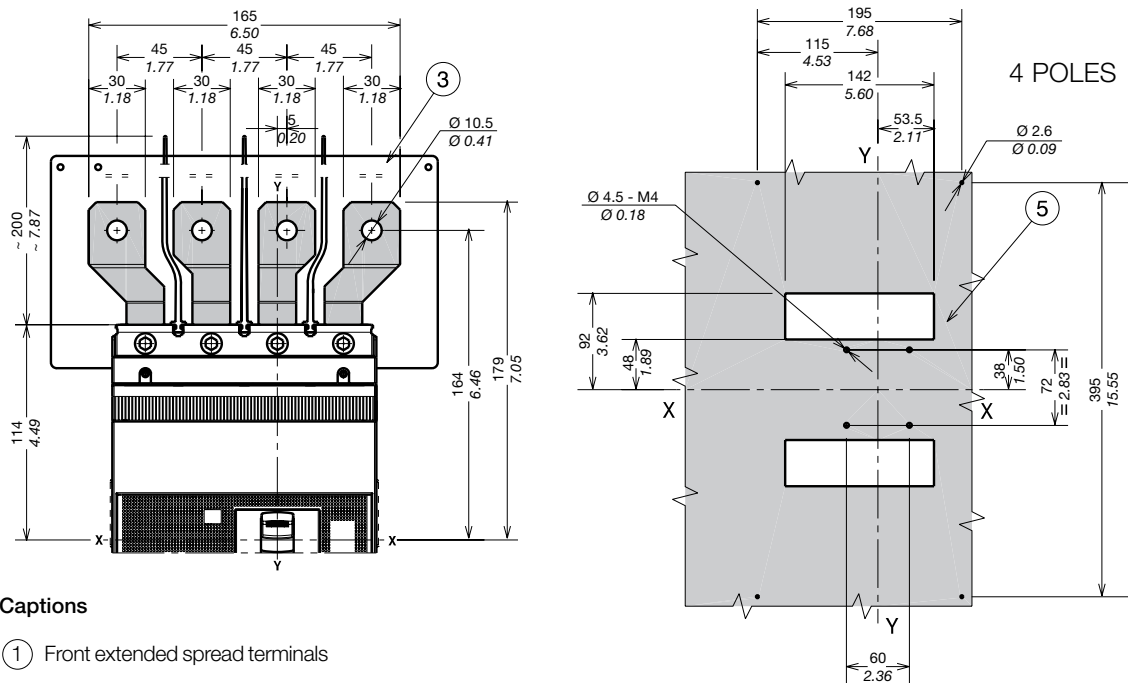
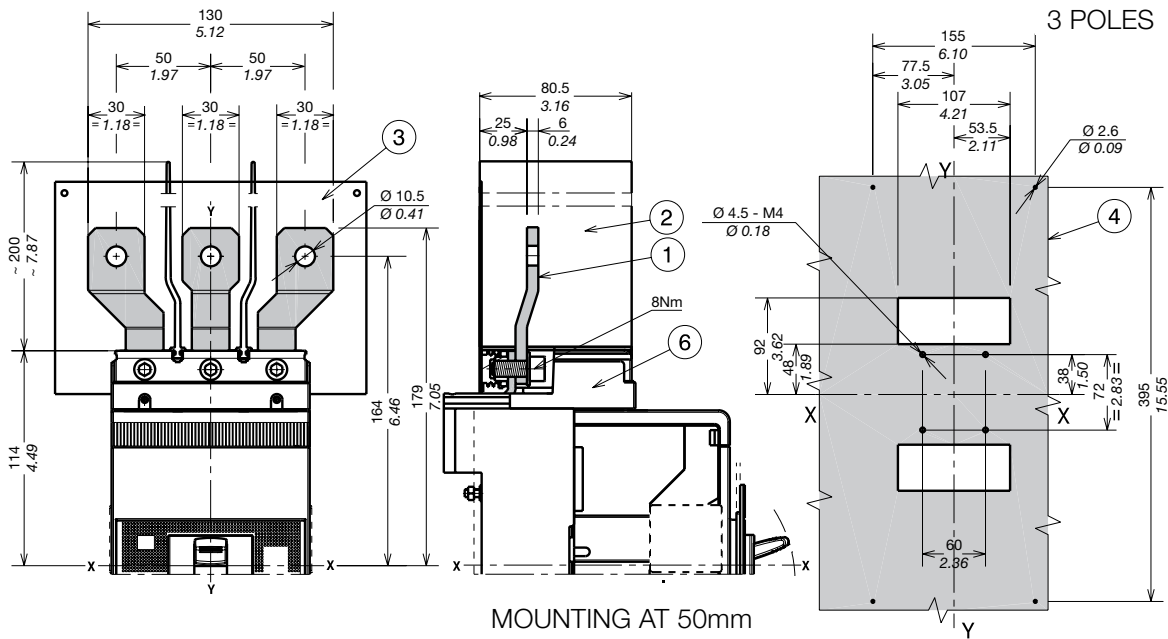

Captions

- ① Front extended spread terminals
- ② 200mm insulating barriers between phases (compulsory) provided
- ③ Insulated plate (compulsory) provided
- ④ Drilling template for 3p circuit breaker
- ⑤ Drilling template for 4p circuit breaker
- ⑥ Adapter (compulsory) not provided

1x2.5...50mm² terminals FCCuAl

Captions

- ① 1x1...185mm² front terminals FCCuAl
- ② 25mm insulating barriers between phases (compulsory) provided
- ⑥ Adapter (compulsory) not provided

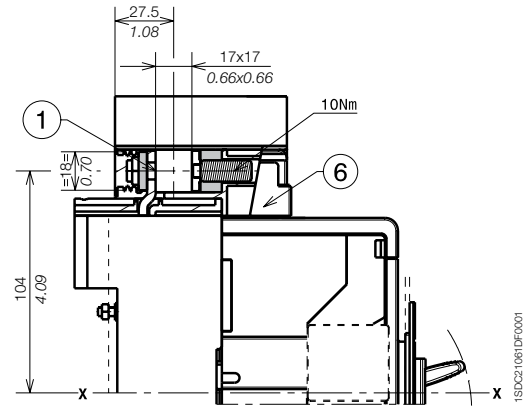
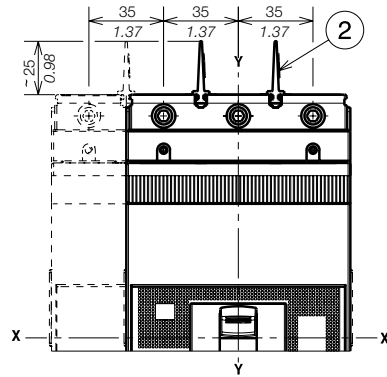

MOUNTING AT 50mm

1SD021061DF0001

Terminals MC

Captions

- ③ Provided high terminal covers with degree of protection IP40 (compulsory for multicable terminals)
- ④ Multicable terminals
- ⑥ Adapter (compulsory) not provided

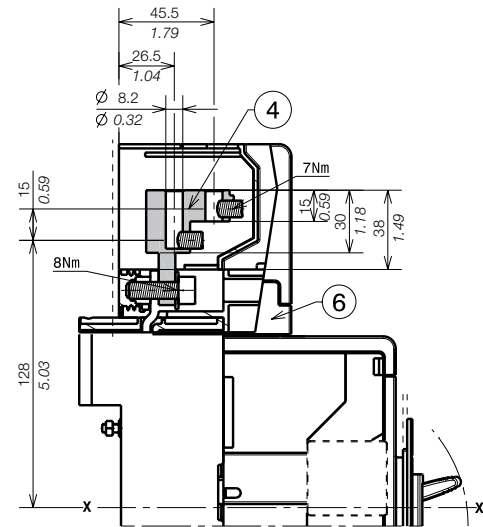
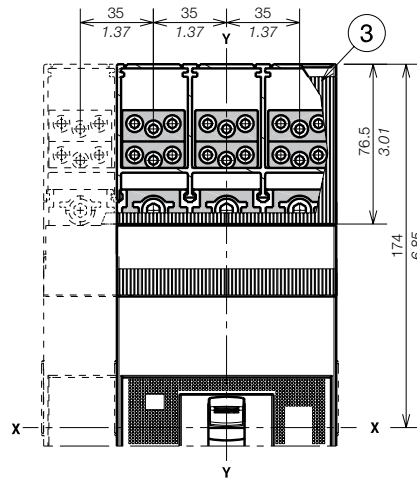

MOUNTING AT 50mm

1SD021063DF0001

Overall dimensions

Tmax XT4 - Terminals for plug-in circuit breaker

Terminals HR/VR

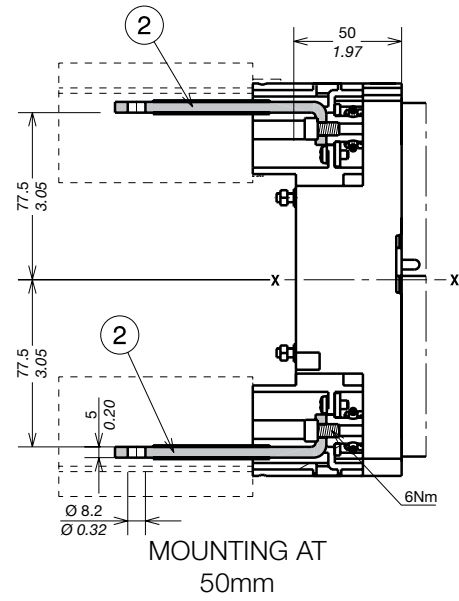
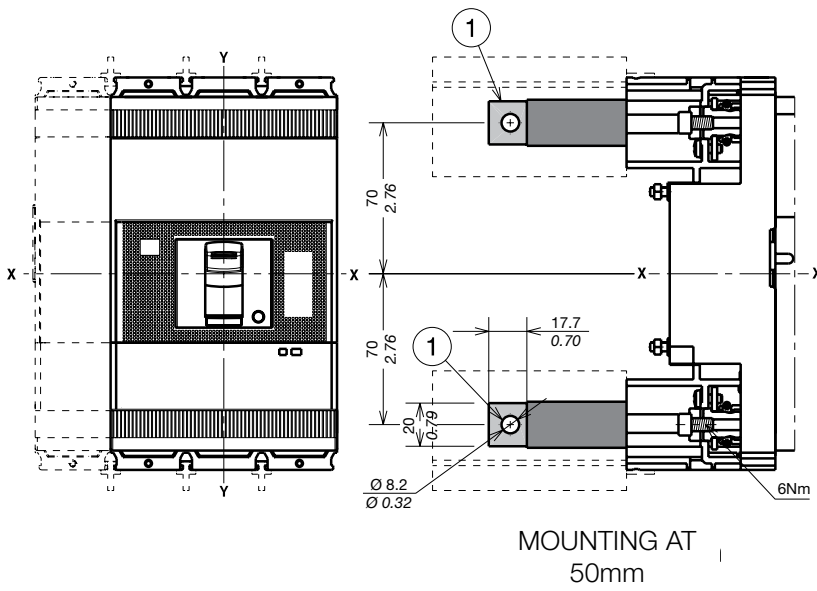

Captions

- ① Rear vertical terminals
- ② Rear horizontal terminals
- ③ 90mm insulating barriers between phases (compulsory not provided)

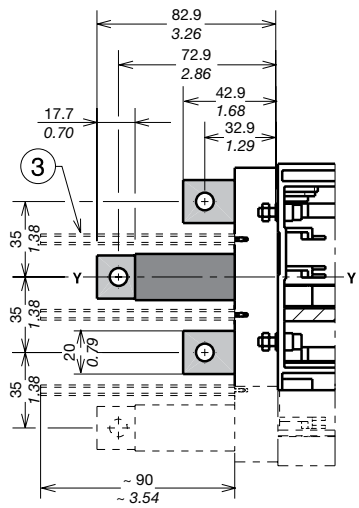
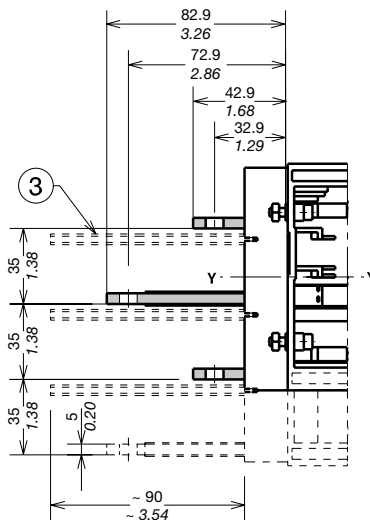

1SDC210611FC001

Overall dimensions

Tmax XT4 - Accessories for plug-in circuit breaker

Stored energy motor operator (MOE)

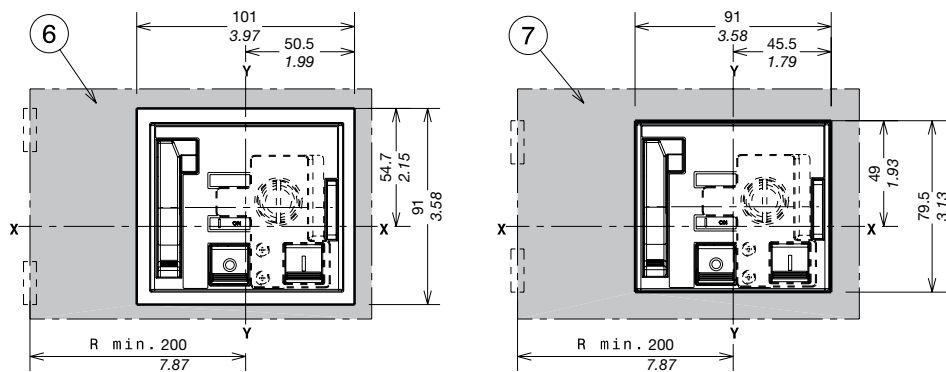
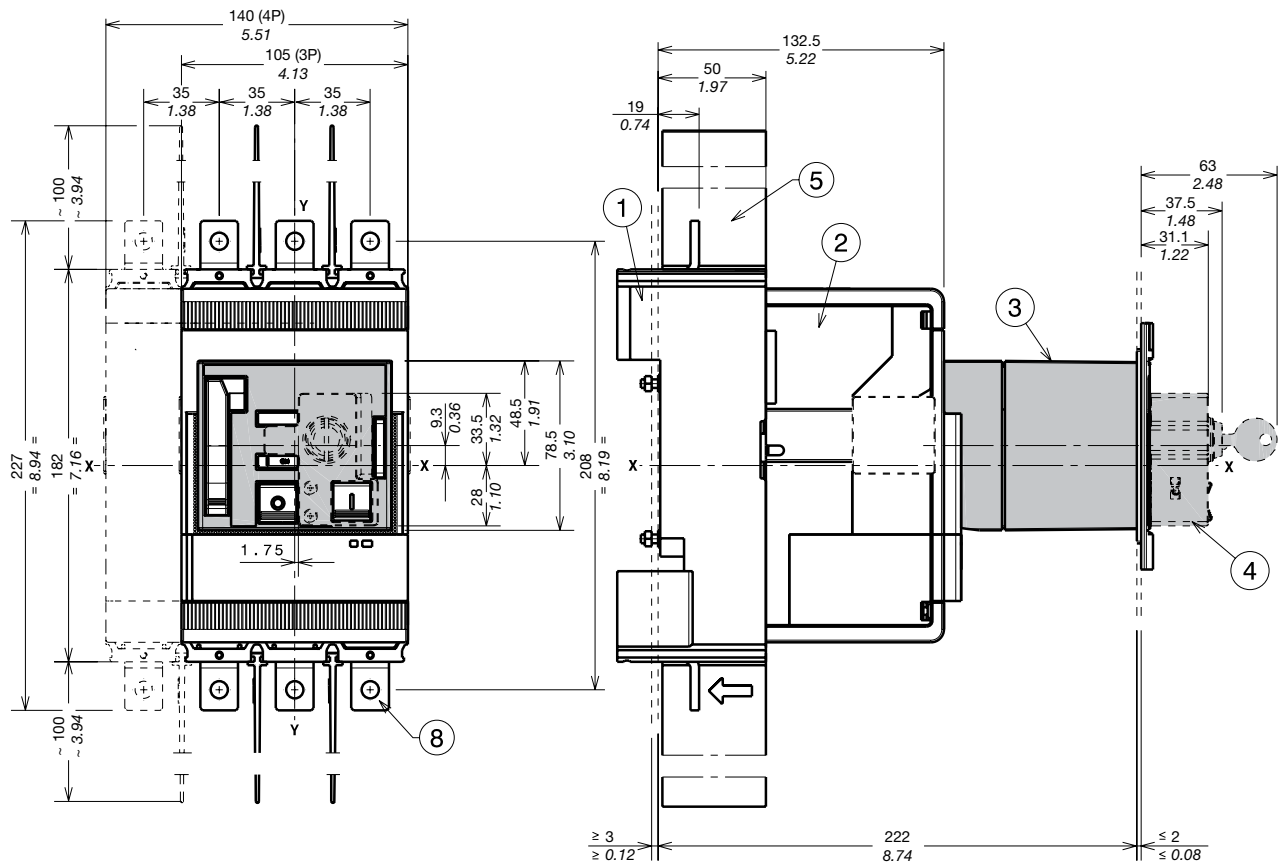

Captions

- ① Fixed part
- ② Moving part
- ③ Stored energy motor operator (MOE)
- ④ Key lock (not provided)
- ⑤ 100mm insulating barriers between phases (compulsory) provided
- ⑥ Drilling template of door with direct rotary handle with flange
- ⑦ Drilling template of door with direct rotary handle without flange
- ⑧ Extended terminals

1SDC21062P0001

Overall dimensions

Tmax XT4 - Accessories for plug-in circuit breaker

Front for lever operating mechanism (FLD)

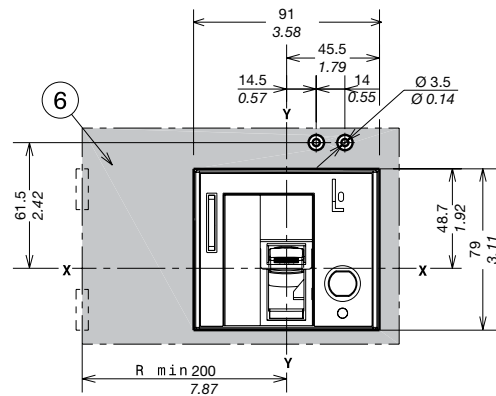
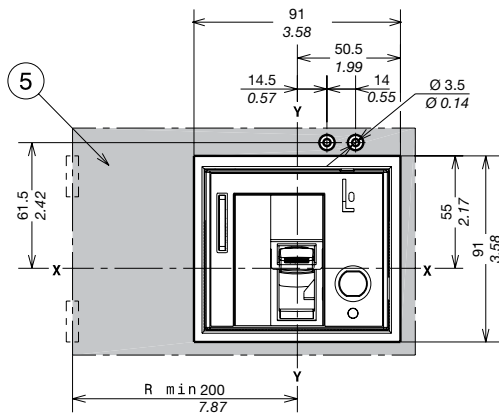
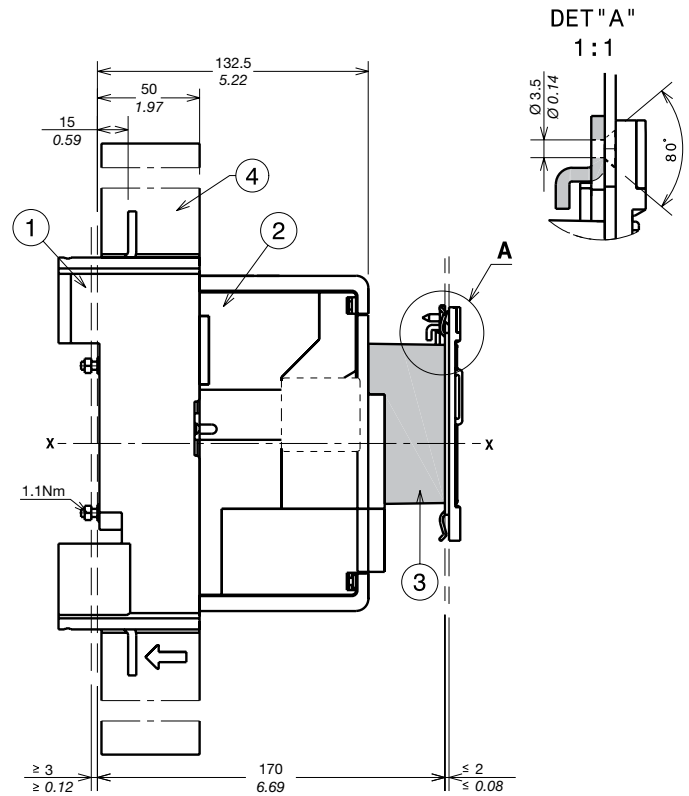
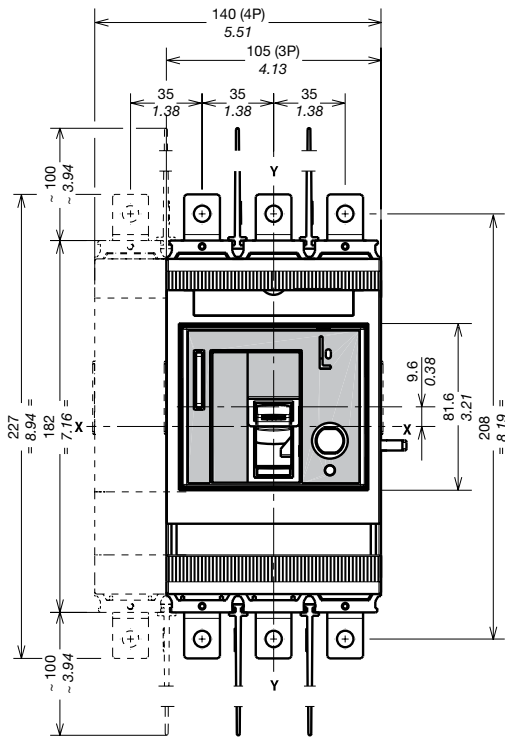

Captions

- ① Fixed part
- ② Moving part
- ③ Front for lever operating mechanism (FLD)
- ④ 100mm insulating barriers between phases (compulsory) provided
- ⑤ Drilling template of door with direct rotary handle with flange
- ⑥ Drilling template of door with direct rotary handle without flange

Ekip Display or LED Meter

Captions

- ① 100mm insulating barriers between phases (compulsory) provided
- ② Ekip Display or LED Meter

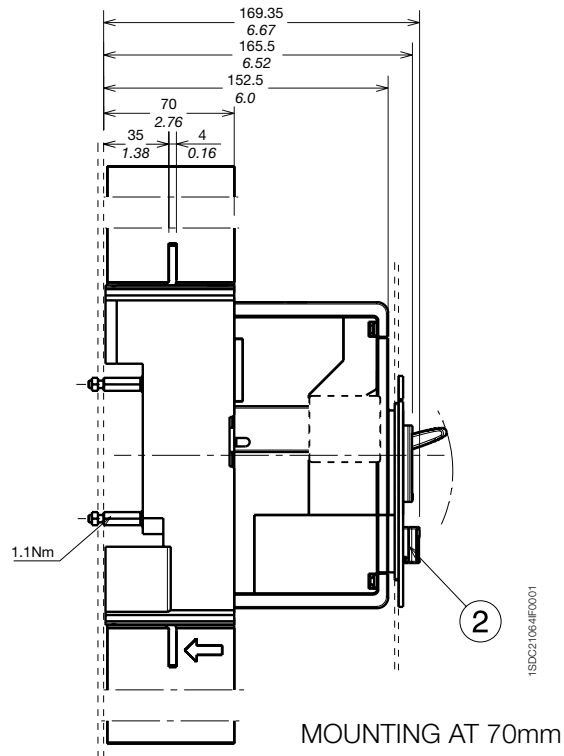
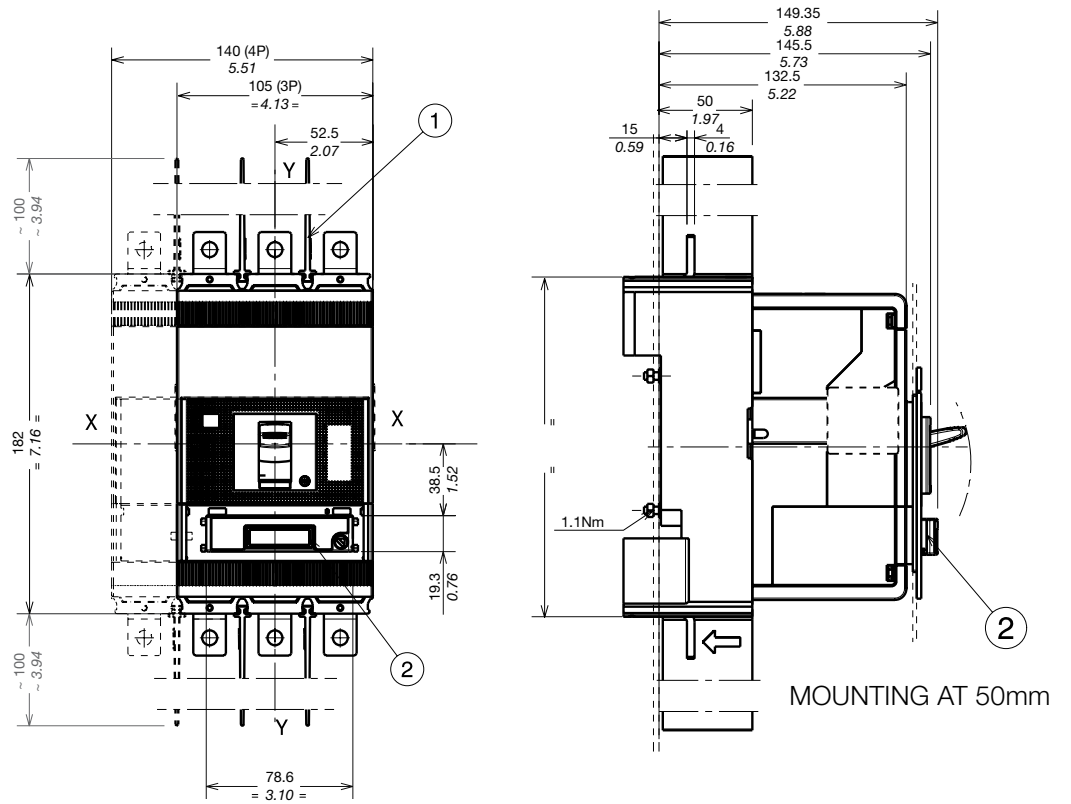

1SD021064R0001

Overall dimensions

Tmax XT4 - Accessories for plug-in circuit breaker

Residual current RC Sel

Captions

- ① Residual current
- ③ Fixed part
- ④ Moving part
- ⑤ 100mm insulating barriers between phases (compulsory) provided
- ⑥ Extended terminals
- ⑦ Drilling template of door with direct rotary handle and mounting with flange
- ⑧ Drilling template of door with direct rotary handle and mounting without flange
- ⑨ Drilling template for mounting circuit breaker on sheet

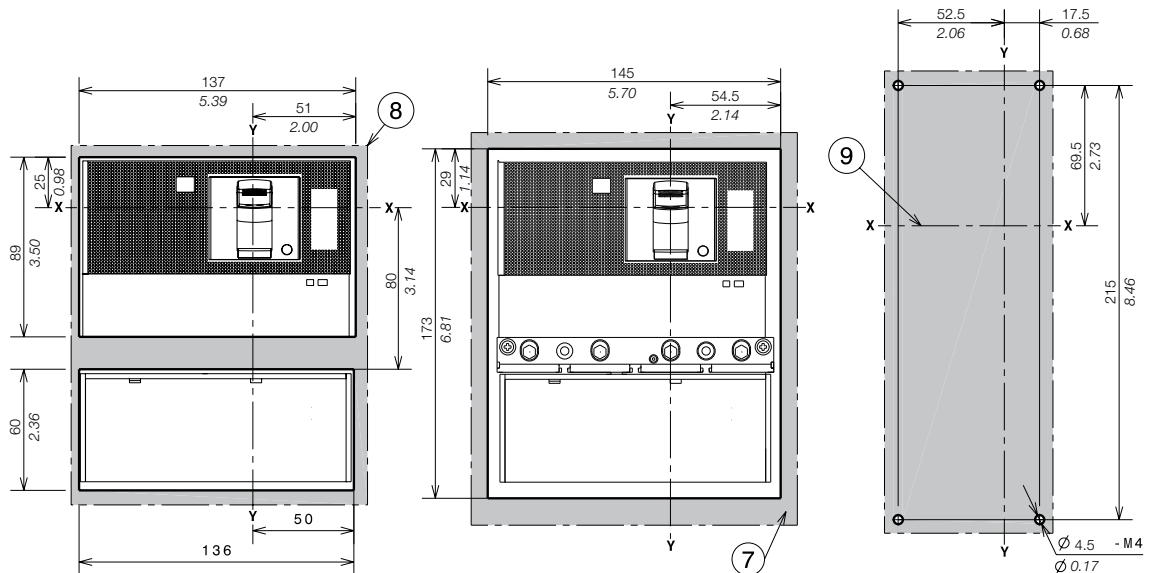
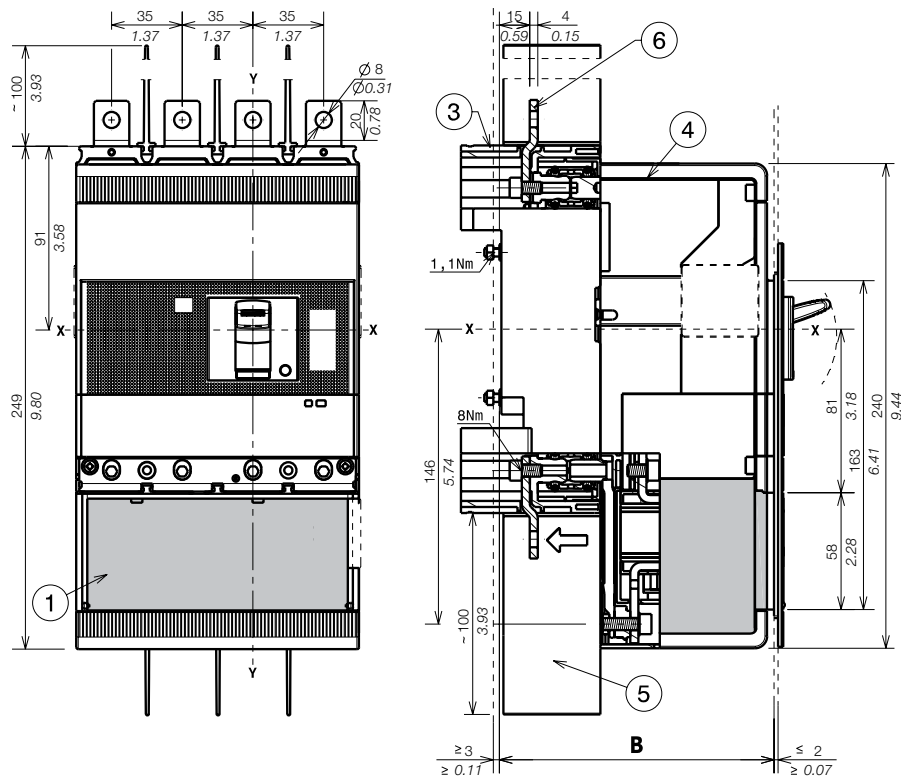

		B
With standard flange	IV	136
Without flange	IV	133.5

Overall dimensions

Tmax XT4 - Installation for withdrawable circuit breaker

Drilling templates for the backplate

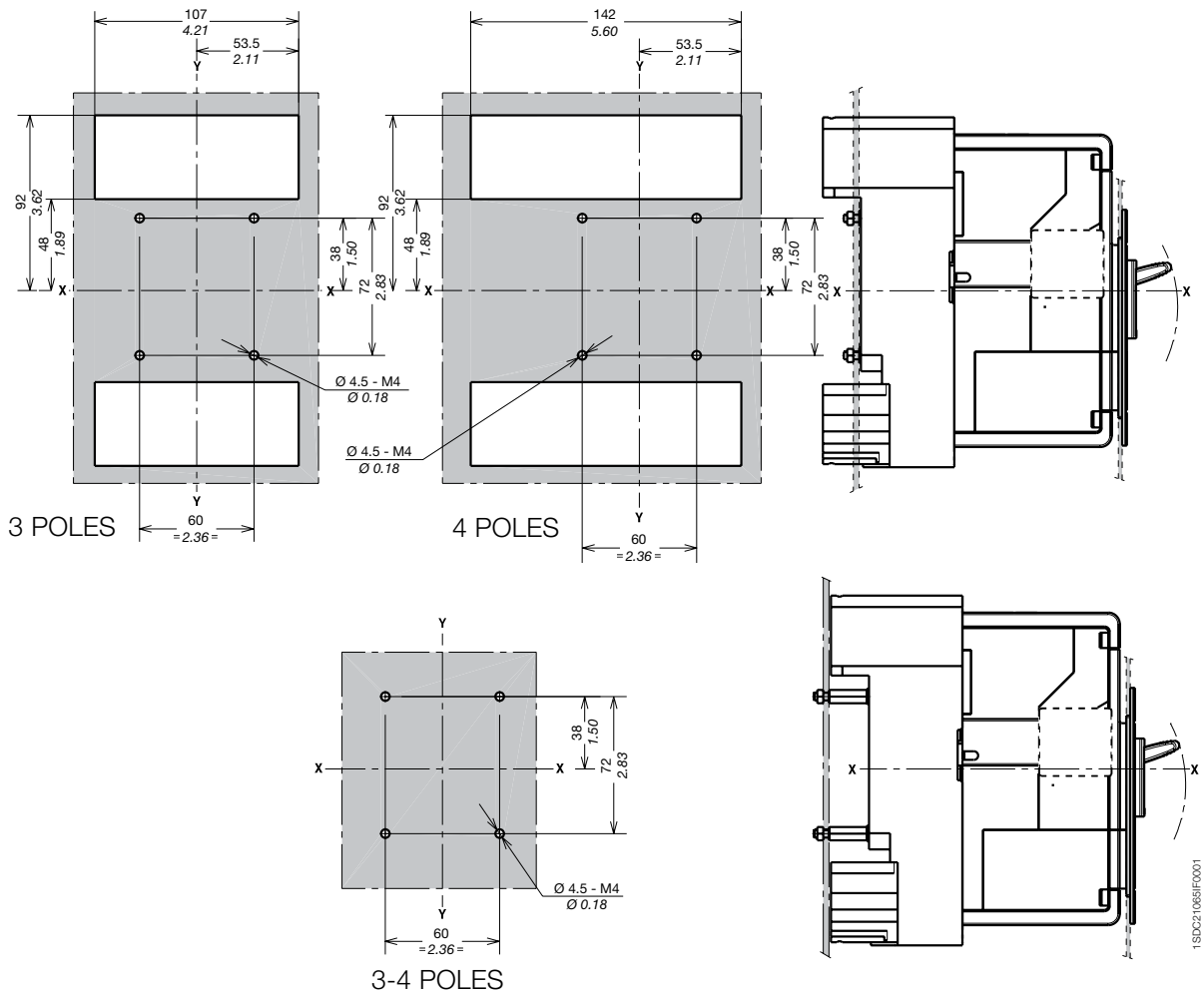

Flanges

Captions

- ① Flange for withdrawable circuit breaker III-IV

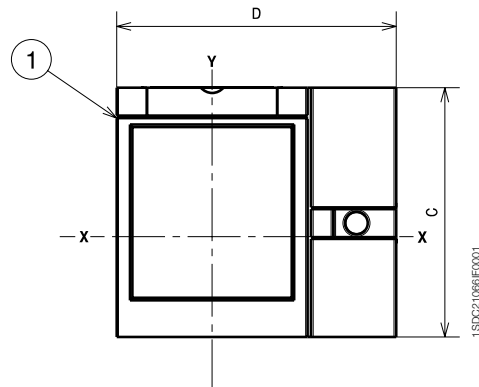

	C	D
RHD	111	124.5
FLD - MOE	114.3	134.5

Overall dimensions

Tmax XT4 - Installation for withdrawable circuit breaker

Drilling templates for compartment door

With standard flange

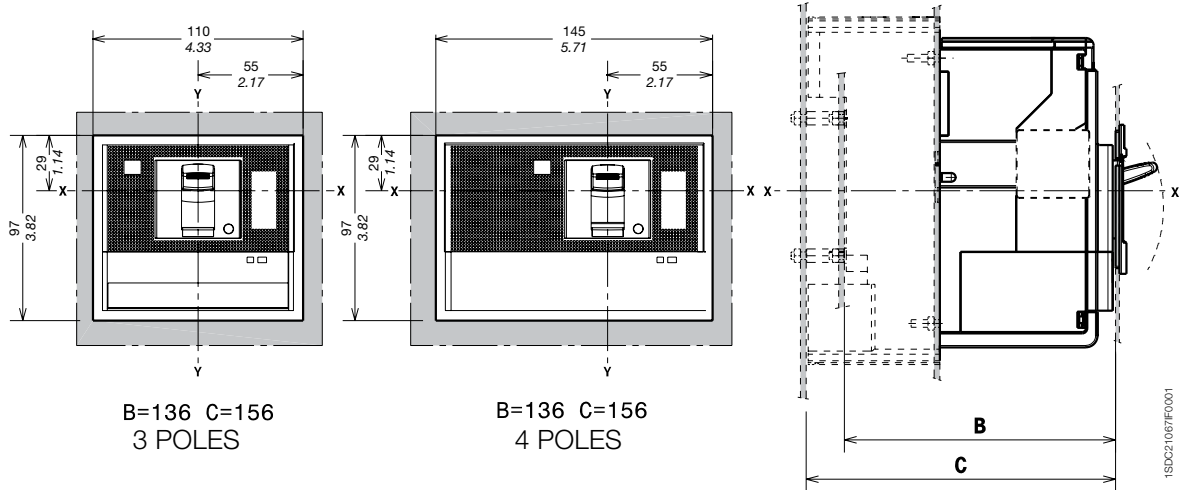

Without flange

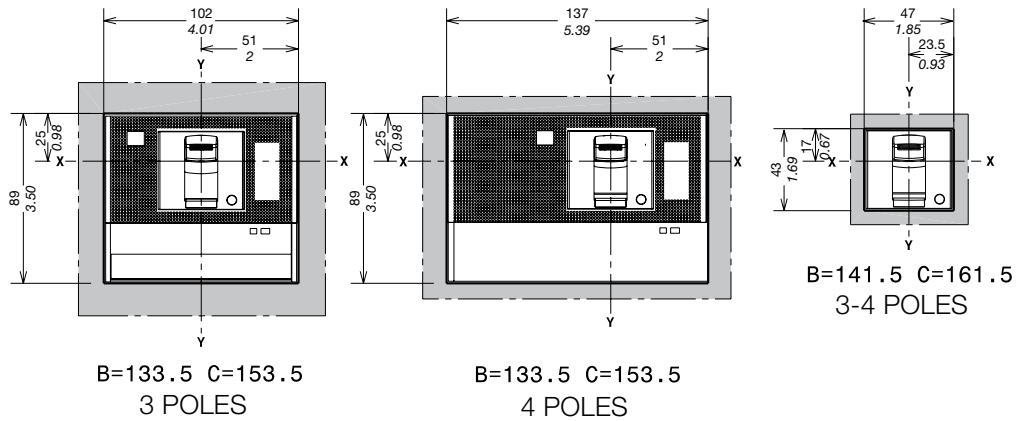

With optional flange

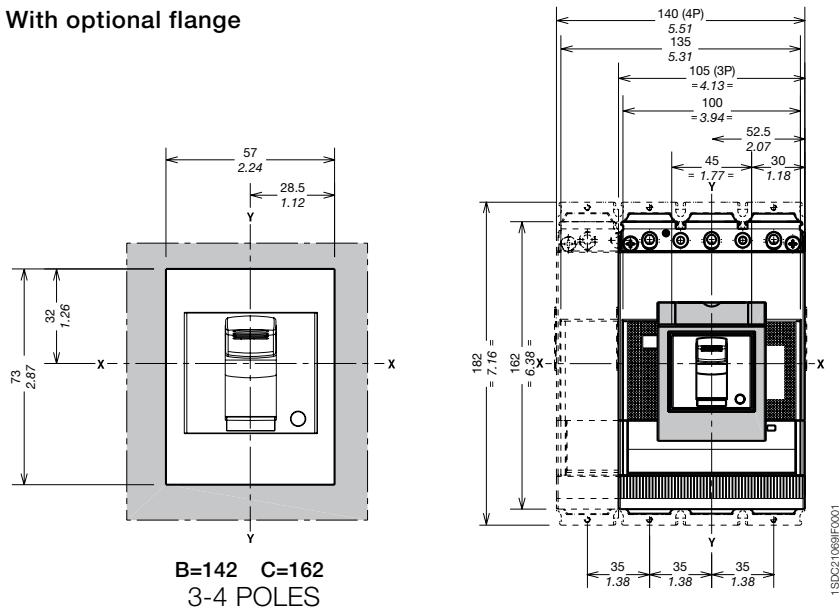

Overall dimensions

Tmax XT4 - Terminals for withdrawable circuit breaker

Terminals EF

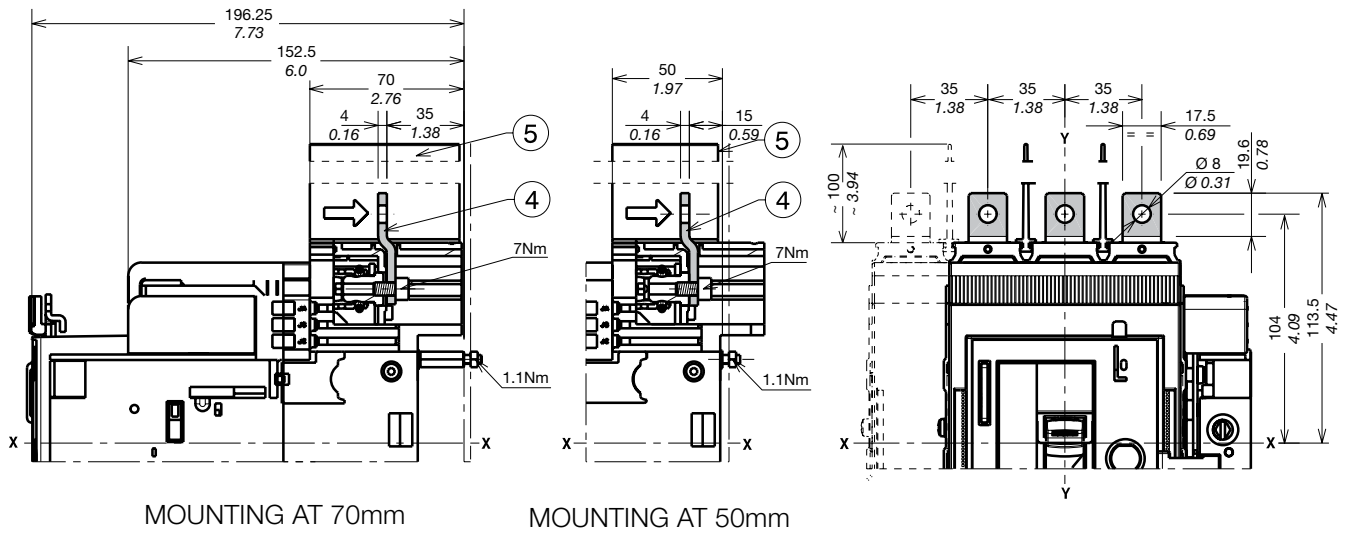

Captions

- ④ Front extended terminals
- ⑤ 100mm insulating barriers between phases (compulsory) provided

Note: insulated plate (compulsory) provided

Overall dimensions

Tmax XT4 - Terminals for withdrawable circuit breaker

Terminals ES

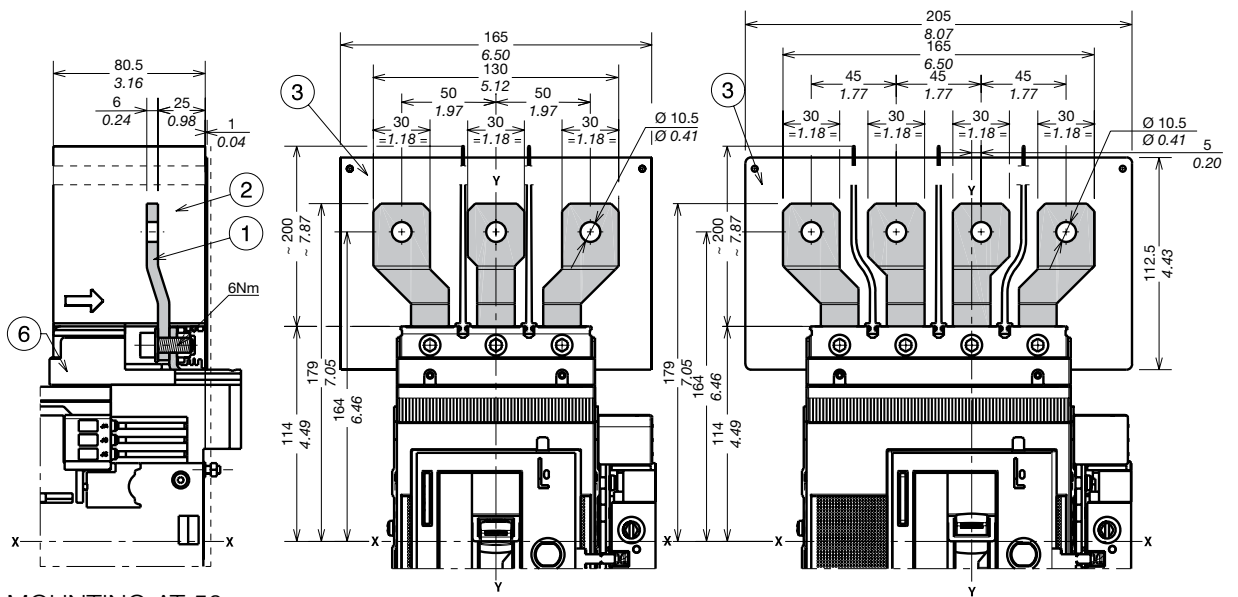

MOUNTING AT 50 mm

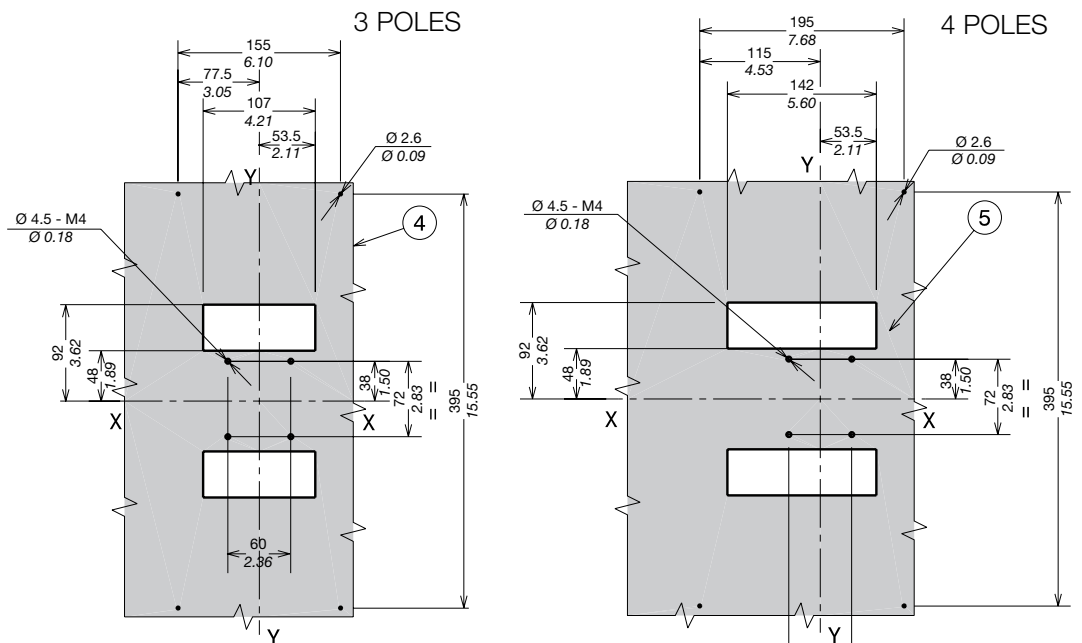

Captions

- ① Front extended spread terminals
- ② 200mm insulating barriers between phases (compulsory) provided
- ③ Insulated plate provided compulsory for $U_e > 440V$
- ④ Drilling template for 3p circuit breaker
- ⑤ Drilling template for 4p circuit breaker
- ⑥ Adapter (compulsory) not provided

1x2.5...50mm² terminals FCCuAl

Captions

- ② 25mm insulating barriers between phases (compulsory) provided
- ④ Front terminals FCCuAl
- ⑤ Adapter (compulsory) not provided

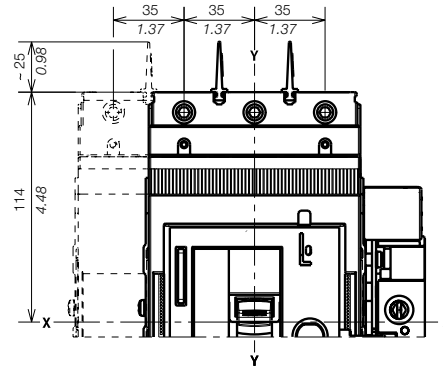
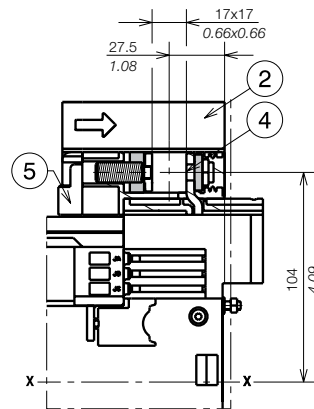

1SDC21076DF0001

MOUNTING AT 50 mm

Terminals FCCu

Captions

- ① 25mm insulating barriers between phases (compulsory) provided as standard with the circuit breaker
- ② Terminals FCCu
- ③ Adapter (compulsory) not provided

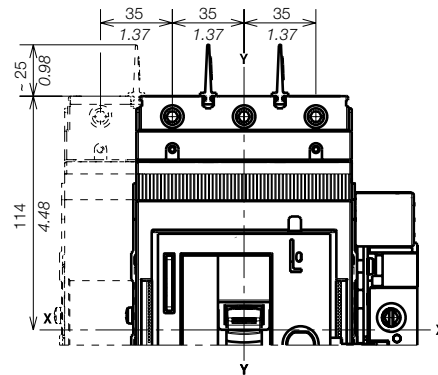
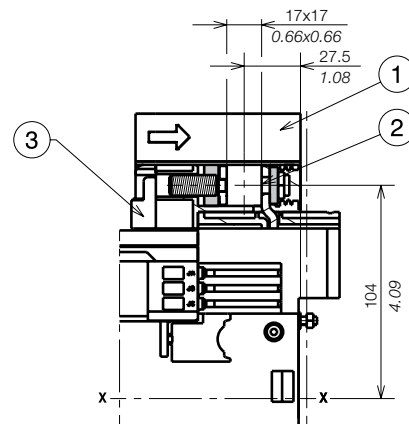

1SDC21036GF0001

MOUNTING AT 50 mm

Terminals MC

Captions

- ① Multicable terminals
- ③ High terminal covers with degree of protection IP40 (optional) provided
- ④ Adapter (compulsory) not provided

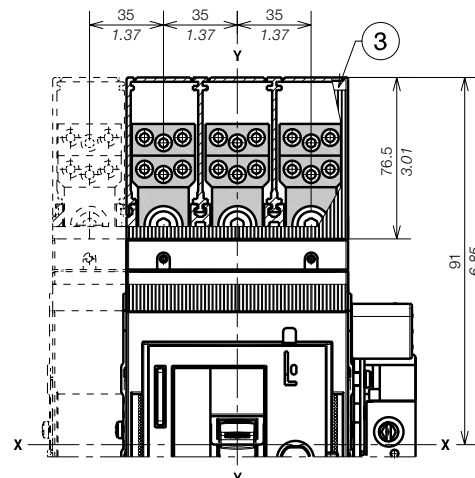
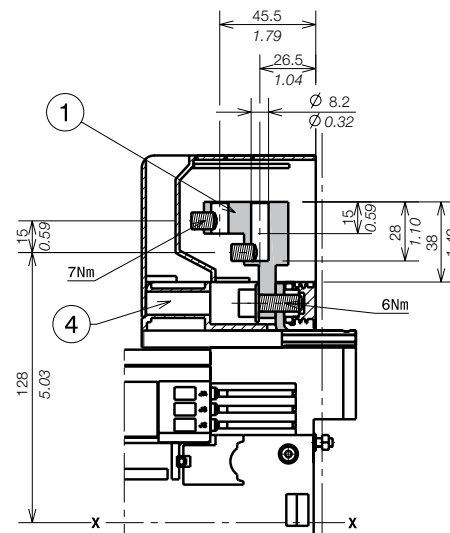

1SDC21079DF0001

MOUNTING AT 50 mm

Overall dimensions

Tmax XT4 - Terminals for withdrawable circuit breaker

Terminals HR/VR

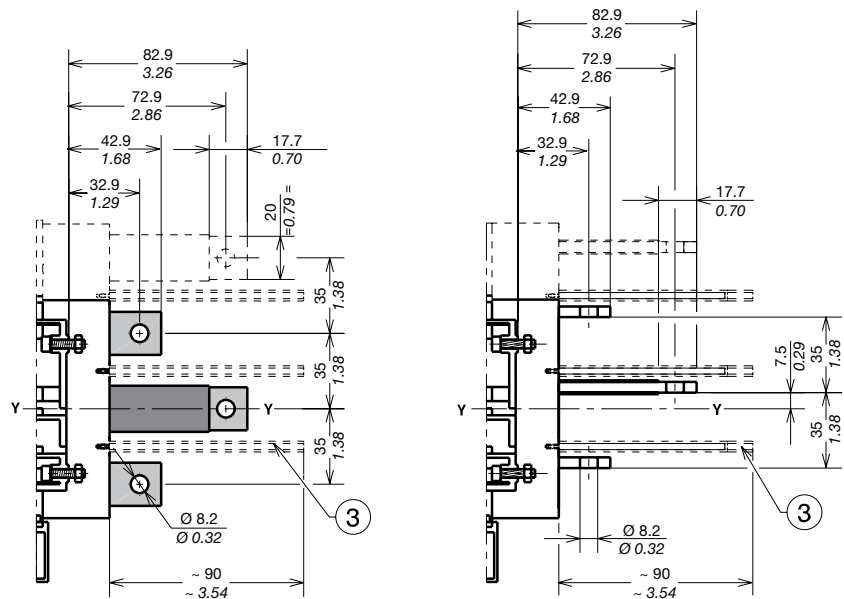
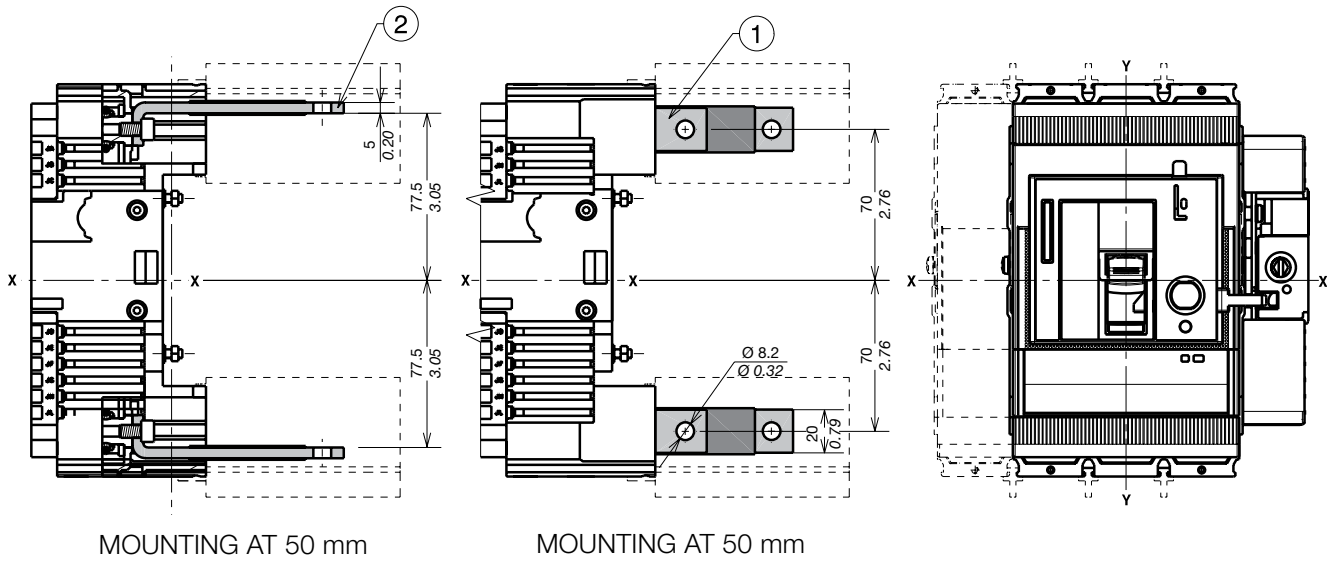

Captions

- ① Rear vertical terminals
- ② Rear horizontal terminals
- ③ 90mm insulating barriers between phases (compulsory) not provided

1SDXC21071R0001

Overall dimensions

Tmax XT4 - Accessories for withdrawable circuit breaker

Stored energy motor operator (MOE)

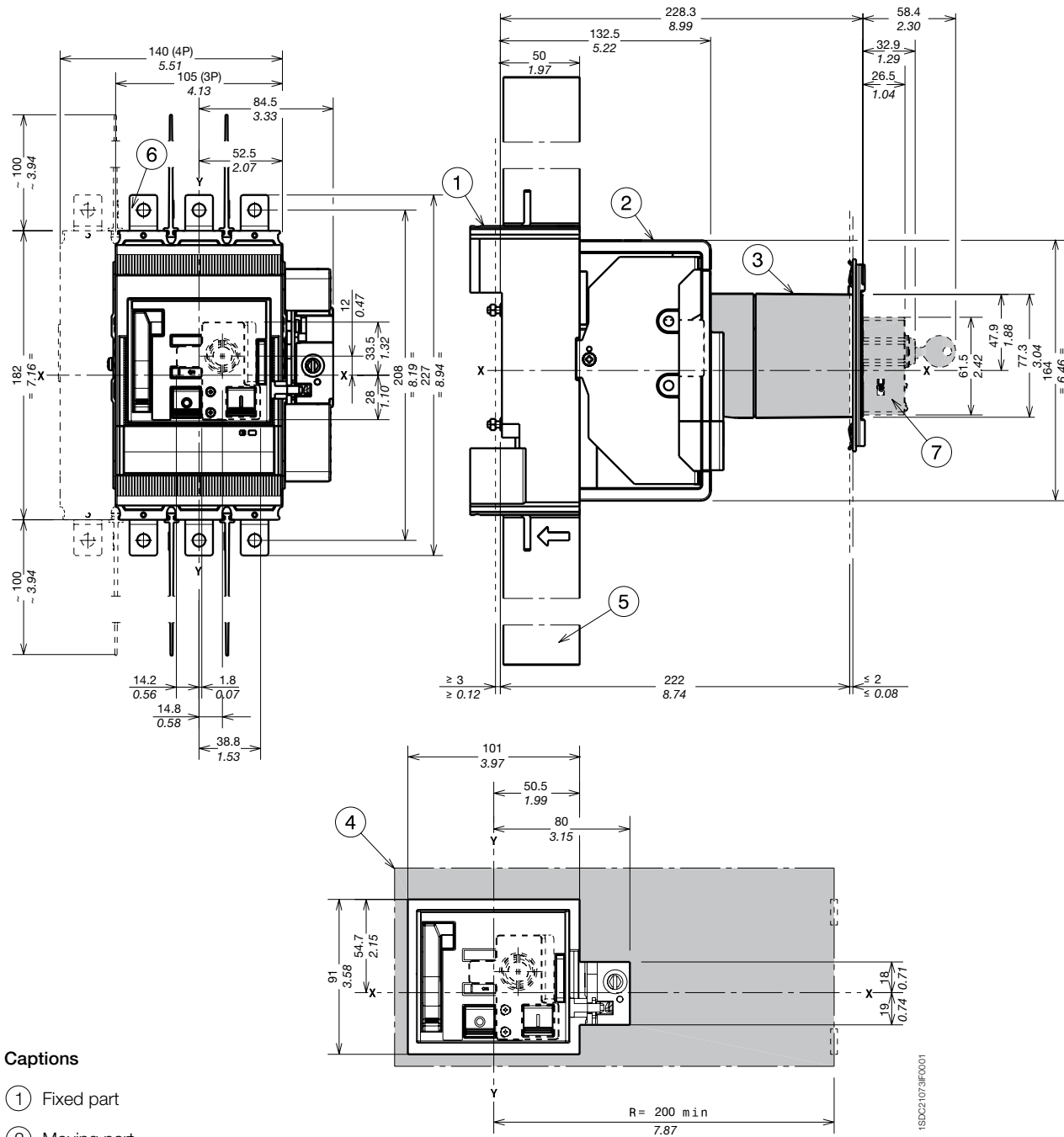

Captions

- ① Fixed part
- ② Moving part
- ③ Stored energy motor operator (MOE)
- ④ Drilling template of door with MOE and fixing flange
- ⑤ 100mm insulating barriers between phases (compulsory) provided
- ⑥ Extended terminals
- ⑦ Key lock (not provided)

Overall dimensions

Tmax XT - Common accessories

Horizontal interlock XT series

Captions

- ① Interlocking mechanism
- ② Drilling template for mounting interlocking system
- ③ Drilling template for all versions with rear terminals
- ④ Tightening torque 3.7Nm
- ⑤ Tightening torque 3Nm
- ⑥ Tightening torque 2.5Nm
- ⑦ Coupling plate for circuit breakers
- ⑧ Breaking for 4p version
- ⑨ A = 35mm XT4 withdrawable with key lock for fixed part
A = 25mm XT2 withdrawable with key lock for fixed part

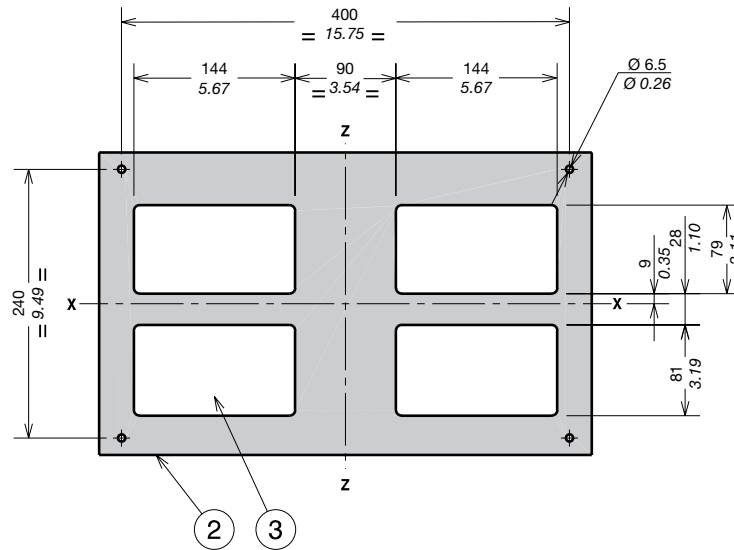
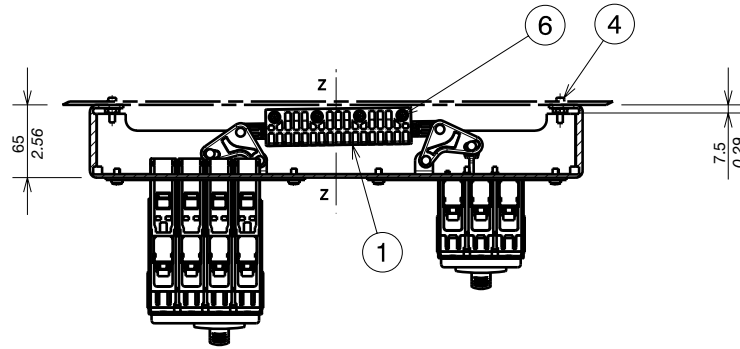
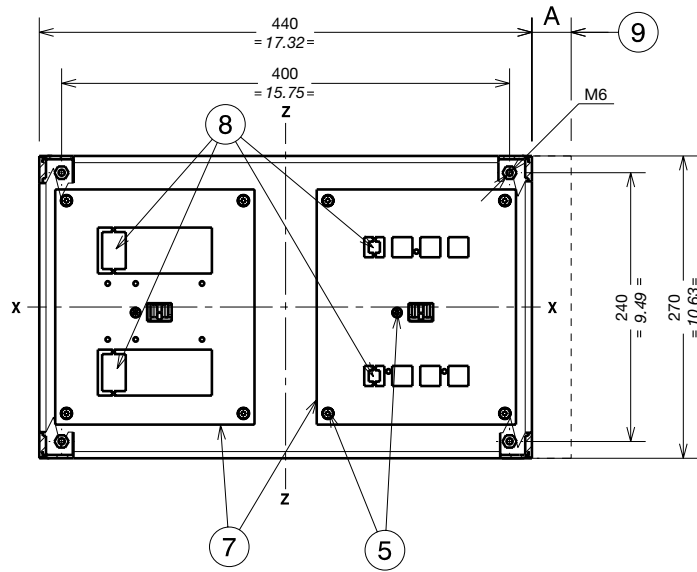

1SD021074IF0001

Overall dimensions

Distances to be respected

Insulation distances for installation in metallic cubicles

Circuit breakers	A (mm/in)	B (mm/in)	C (mm/in)
XT1	120 / 4.72	70 / 2.76	120 / 4.72
XT2	90 / 3.54	45 / 1.77	90 / 3.54
XT3	110 / 4.34	55 / 2.17	110 / 4.34
XT4	110 / 4.34	45 / 1.77	110 / 4.34

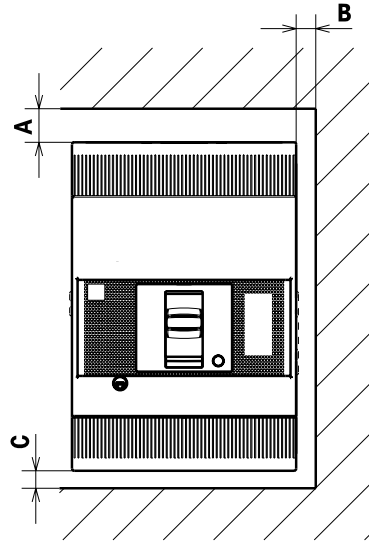

Wiring diagrams

Information on how to read the diagrams	6/2
Graphic symbols (IEC 60617 and CEI 3-14...3-26 Standards)	6/3
Wiring Diagrams of the circuit breakers	6/4
Wiring Diagrams of the accessories	6/8
Resetting instructions	6/22

Wiring diagrams

Information on how to read the diagrams

Shown

The diagrams are shown in the following conditions:

- fixed version circuit breaker, open;
- withdrawable or plug-in version circuit breaker, open and connected;
- contactor for starting the motor open;
- circuits de-energized;
- trip units not tripped;
- motor operator with springs charged.

The diagram shows a circuit breaker or a switch-disconnector in the withdrawable or plug-in version, but is also valid for fixed version circuit breakers or switch-disconnectors.

For fixed version circuit breakers, auxiliary circuits are headed at terminal box XV: connectors J.. and XB.., XC.., XD.. and XE.. are not supplied.

For plug-in version circuit breakers, auxiliary circuits are headed at connectors XB.., XC.., XD.. and XE..: connectors J.. are not supplied.

For withdrawable version circuit breakers, auxiliary circuits are headed at connectors J..: connectors XB.., XC.., XD.. and XE.. are not supplied.

Wiring diagrams

Graphic symbols (IEC 60617 and CEI 3-14 ...3-26 Standards)

	Thermal effect		Conductors with corded cables (example two conductors)		Opening contact		Overcurrent release with short adjustable time delay characteristic
	Electromagnetic effect		Connection of conductors		Changeover contact with momentary break		Overcurrent release with short inverse adjustable time delay characteristic
	Timing		Terminal or clamp		Closing position contact (limit switch)		Overcurrent release with long inverse adjustable time delay characteristic
	Mechanical connection		Socket and plug (female and male)		Opening position contact (limit switch)		Overcurrent release for earth fault with short inverse time characteristic
	Manual mechanical operating mechanism (general case)		Resistor (general symbol)		Changeover contact with momentary break (limit switch)		Current relay for unbalance between phases
	Rotary handle operating mechanism		Resistor dependent on the temperature		Contactor (closing contact)		Residual current release
	Pushbutton operating mechanism		Motor (general symbol)		Power cut-off of switch-disconnector power with automatic opening		Relay for detecting lack of phase in a three-phase system
	Key operating mechanism		Three-phase asynchronous motor, with short-circuited rotor (cage)		Switch-disconnector		Relay for detecting blocked rotor by means of current measurement
	Cam operating mechanism		Current transformer		Control coil (general symbol)		Lamp, general symbol
	Ground (general symbol)		Current transformer with primary consisting of 4 passing conductors and with wound secondary, with socket		Thermal trip unit		Motor with excitation in series
	Converter separated galvanically		Closing contact		Instantaneous overcurrent release		Brush
	Conductors in shielded cable (example two conductors)		Voltmeter		Ammeter		Wattmeter
	Watt-hour meter						

Wiring diagrams of the circuit breakers

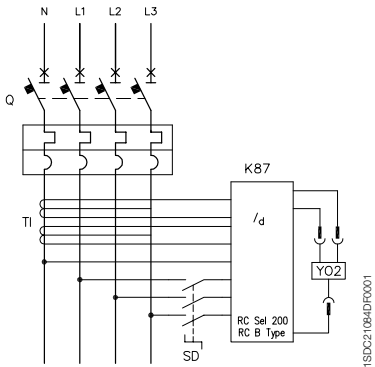

Four-pole circuit breaker with thermomagnetic trip unit and RC Sel 200 or RC B type residual current release

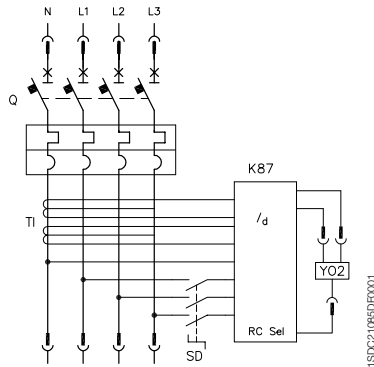

Four-pole circuit breaker with thermomagnetic trip unit and RC Sel residual current release

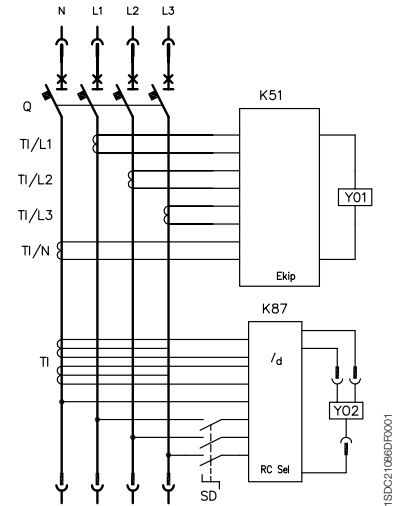

Four-pole circuit breaker with electronic trip unit and RC Sel residual current release

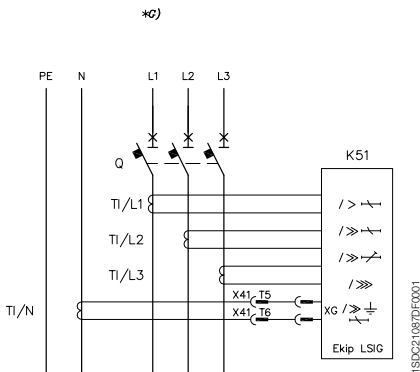

Three-pole fixed version circuit breaker with current transformer on the neutral conductor outside the circuit breaker

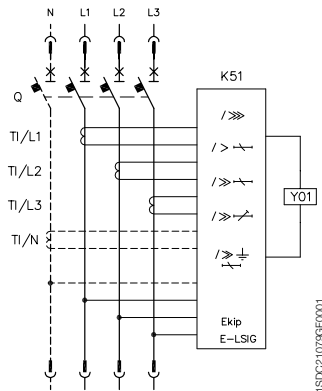

Three-pole or four-pole XT4 circuit breaker with Ekip E-LSIG microprocessor based release

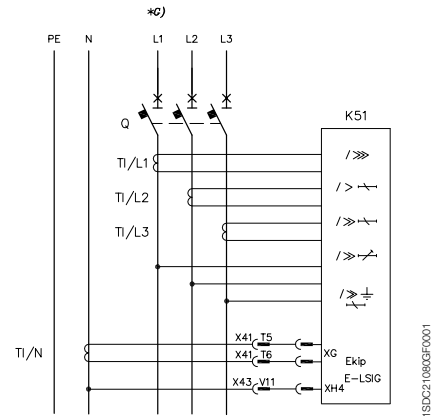

Fixed version three-pole XT4 circuit breaker with Ekip E-LSIG with current transformer on neutral conductor, external to circuit breaker

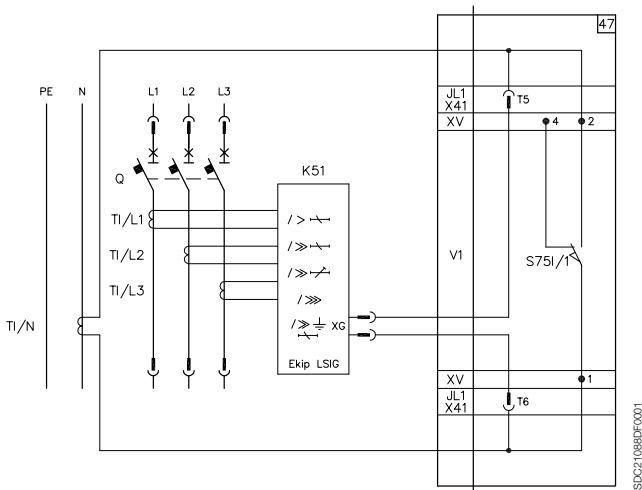
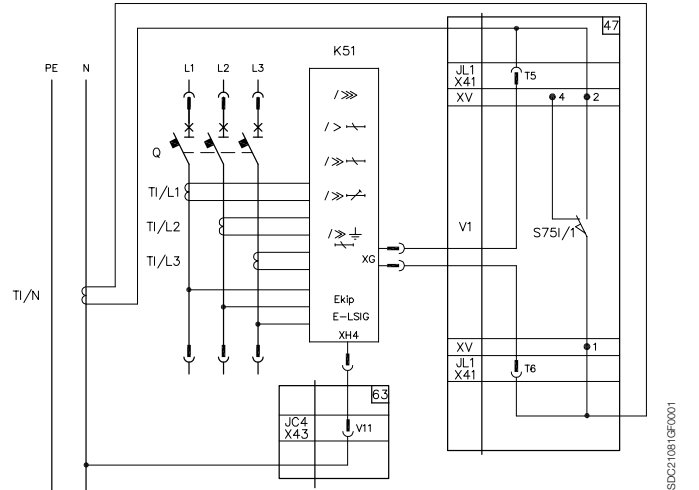

Diagram recommended for three-pole plug-in or withdrawable version circuit breakers with current transformer on the neutral conductor outside the circuit breaker



Recommended diagram for plug-in or withdrawable version three-pole circuit breakers with current transformer and voltage connection on neutral conductor, external to circuit breaker

Description of figures

- Fig. 47 = Current transformer circuit on the neutral conductor outside the circuit breaker (for plug-in or withdrawable version circuit breaker).
- Fig. 63 = Circuit of the voltage socket on the neutral conductor outside the circuit breaker (for Ekip E_LSIG type microprocessor-based plug-in or withdrawable circuit breaker).

Notes

- G) To remove the circuit breaker from a three-pole fixed version with a current transformer on the neutral conductor outside the circuit breaker, the TI/N transformer terminals must be short-circuited.

Caption

- = Diagram figure number
- * = See the note indicated by the letter
- J.. = Connectors for the auxiliary contacts of the withdrawable version circuit breaker; connectors and circuit breaker are extracted simultaneously.
- K51 = Electronic trip unit:
– overcurrent release type Ekip I, Ekip LS/I, Ekip N-LS/I, Ekip LSI, Ekip LSIG, Ekip E-LSIG
– of motor protection type Ekip M-LIU
- K87 = Residual current release type RC Inst, RC Sel, RC Sel 200, RC B Type
- Q = Main circuit breaker
- S75I/1..4 = Contacts for electrical signaling of circuit breaker in the connected position (only provided with plug-in or withdrawable version circuit breakers)
- S75S/1-2 = Contacts for electrical signaling of circuit breaker in the racked-out position (only provided with withdrawable version circuit breakers)
- SD = Power supply switch-disconnector of the residual current release type RC Inst, RC Sel, RC Sel 200 or RC B Type
- TI = Toroidal current transformer
- TI/L1 = Current transformer placed on phase L1
- TI/L2 = Current transformer placed on phase L2
- TI/L3 = Current transformer placed on phase L3
- TI/N = Current transformer placed on the neutral
- V1 = Circuit breaker applications
- X41 = Circuit connector for external neutral
- XG-XH = Electronic trip unit connectors
- XV = Terminal boxes of circuit breaker applications
- YO1 = Opening solenoid of the microprocessor-based overcurrent release
- YO2 = Opening solenoid of the residual current release

Wiring diagrams of the circuit breakers

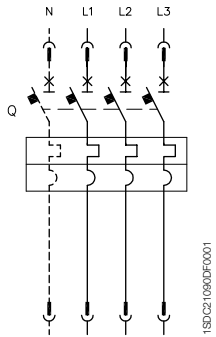

Three-pole or four-pole circuit breaker with TMF or TMA thermomagnetic trip unit

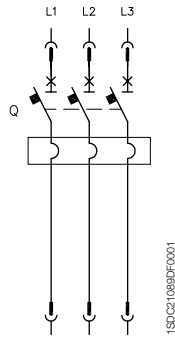

Three-pole circuit breaker with MCP (MA) magnetic trip unit

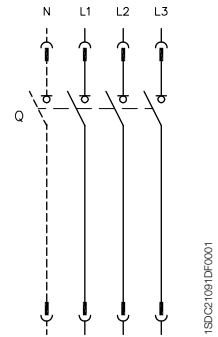

Three-pole or four-pole molded case switch-disconnector

6

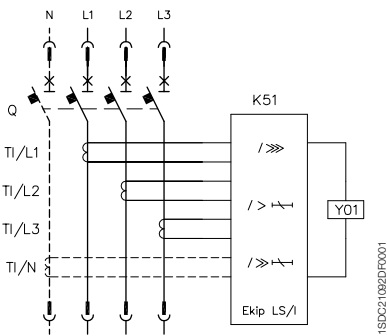

Three-pole or four-pole circuit breaker with Ekip LS/I electronic trip unit

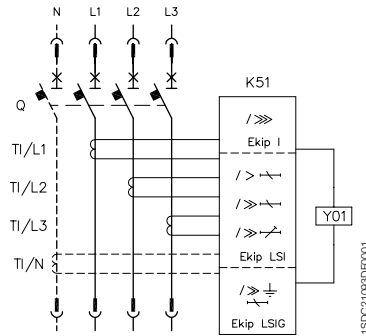

Three-pole or four-pole circuit breaker with Ekip I, Ekip LSI or Ekip LSIG electronic trip unit

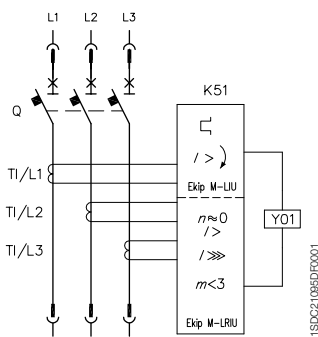

Three-pole circuit breaker with Ekip M-LIU electronic trip unit

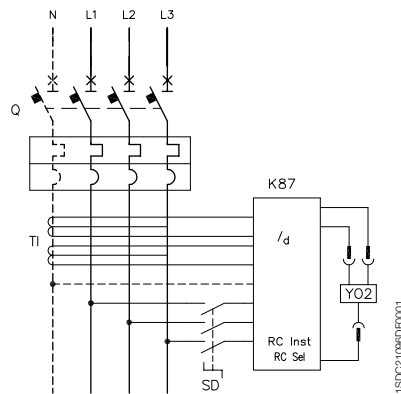

Three-pole or four-pole circuit breaker with thermomagnetic trip unit and RC Inst or RC Sel residual current release

Captions

□	= Diagram figure number
*	= See the note indicated by the letter
K51	= Microprocessor-based release: <ul style="list-style-type: none">– overcurrent release type Ekip I, Ekip LS/I, Ekip N-LS/I, Ekip LSI, Ekip LSIG, Ekip E-LSIG– motor protection release type Ekip M-LIU
K87	= Residual current release type RC Inst, RC Sel, RC Sel 200, RC B Type
Q	= Main circuit breaker
SD	= Power supply switch-disconnector of the residual current release type RC Inst, RC Sel, RC Sel 200 or RC B Type
TI	= Toroidal current transformer
TI/L1	= Current transformer placed on phase L1
TI/L2	= Current transformer placed on phase L2
TI/L3	= Current transformer placed on phase L3
TI/N	= Current transformer placed on the neutral
YO1	= Opening solenoid of the microprocessor-based overcurrent release
YO2	= Opening solenoid of the residual current release

Wiring diagrams of the accessories

Service releases

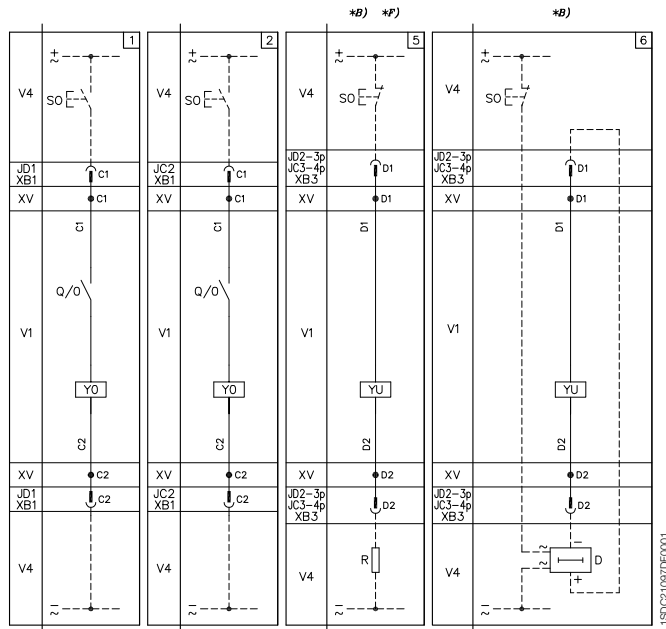

Description of figures

- Fig. 1 = Shunt opening release.
- Fig. 2 = Supplementary shunt opening release (only for four-pole circuit breakers).
- Fig. 5 = Instantaneous undervoltage release (see Notes B and F).
- Fig. 6 = Undervoltage release with electronic time delay device outside the circuit breaker, see note B).

Notes

- B) The undervoltage release is supplied for power supply branched on the supply side of the circuit breaker or from an independent source: closing is only possible with the release energized (the lock on closing is made mechanically).
- F) Additional external resistor for undervoltage supplied at 380/440V AC and 480/525V AC.

Caption

- = Diagram figure number
- * = See the note indicated by the letter
- D = Undervoltage release electronic time delay device (outside the circuit breaker) (only for voltages up to 250V)
- J.. = Connectors for the auxiliary contacts of the withdrawable version circuit breaker; connectors and circuit breaker are extracted simultaneously
- Q/0..7 = Circuit breaker auxiliary contacts
- R = Resistor (see note F)
- SO = Pushbutton or contact for opening the circuit breaker
- V1 = Circuit breaker applications
- V4 = Indicative apparatus and connections for control and signaling, outside the circuit breaker
- XB.. = Three-way connector for the plug-in version circuit breaker auxiliary circuits
- XV = Terminal boxes of circuit breaker applications
- YO = Shunt opening release
- YU = Undervoltage release (see note B)

Service releases

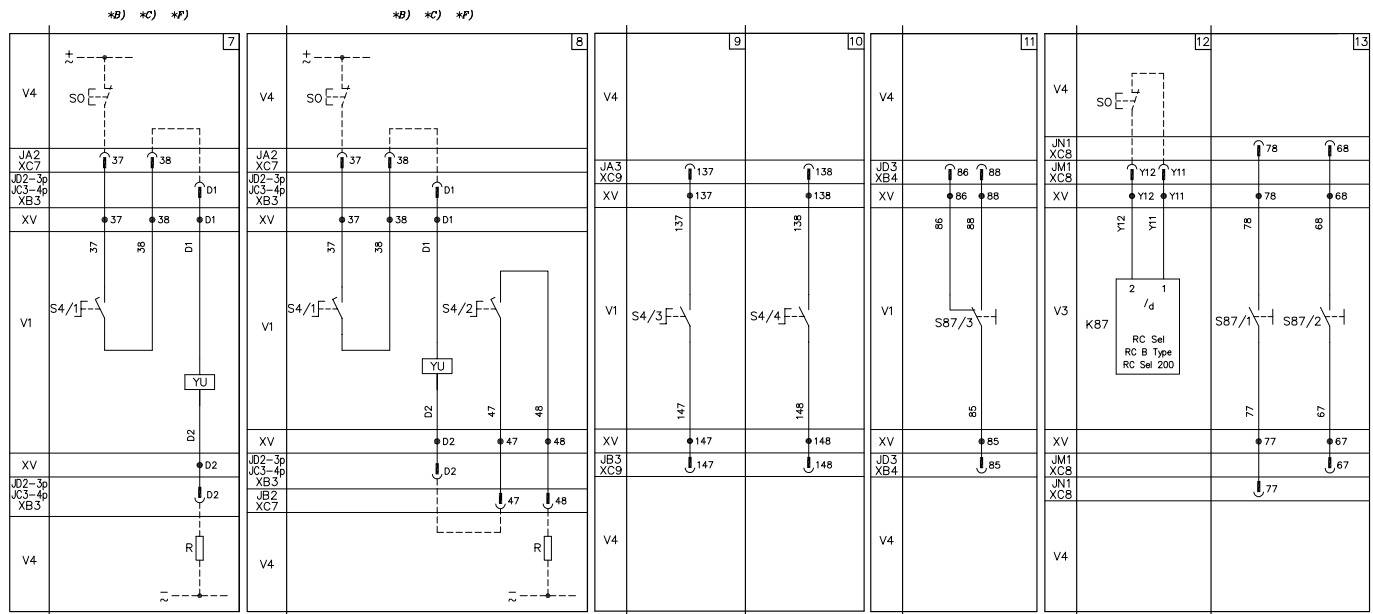

Description of figures

- Fig. 7 = Instantaneous undervoltage release in the version for machine tools with one contact in series (see notes B, C and F).
 Fig. 8 = Instantaneous undervoltage release in the version for machine tools with two contacts in series (see Notes B, C and F).
 Fig. 9 = First auxiliary early contact operated by the crank handle.
 Fig. 10 = Second auxiliary early contact operated by the crank handle.
 Fig. 11 = One changeover contact for electrical signaling of circuit breaker open due to tripping of the residual current release type RC Inst, RC Sel, RC B Type or RC Sel 200.
 Fig. 12 = Residual current release circuits type RC Sel, RC B Type or RC Sel 200.
 Fig. 13 = Two contacts for electrical signaling of residual current release pre-alarm and alarm type RC Sel, RC B Type or RC Sel 200.

Notes

- B) The undervoltage release is supplied for power supply branched on the supply side of the circuit breaker or from an independent source: closing is only possible with the release energized (the lock on closing is made mechanically).
 C) Contacts S4/1 and S4/2 shown in figures 7-8 open the circuit with the circuit breaker open and reclose it when a manual closing command is given by means of the rotary handle, in accordance with the Standards regarding machine tools (in any case closing does not take place if the undervoltage release is not supplied).
 F) Additional external resistor for undervoltage supplied at 480/525V AC.

Caption

- = Diagram figure number
 * = See the note indicated by the letter
 J.. = Connectors for the auxiliary contacts of the withdrawable version circuit breaker; connectors and circuit breaker are extracted simultaneously
 K87 = Residual current release type RC Inst, RC Sel, RC Sel 200, RC B Type
 R = Resistor (see note F)
 S4/1-4 = Auxiliary early contacts operated by the circuit breaker mounted crank handle (see note C)
 S87/1 = Contact for electrical signaling of pre-alarm of the residual current release type RC Sel, RC B or RC Sel 200
 S87/2 = Contact for electrical signaling of alarm of the residual current release type RC Sel, RC B or RC Sel 200
 S87/3 = Contact for electrical signaling of circuit breaker open due to tripping of the residual current release type RC Sel, RC Inst, RC B or RC Sel 200
 SO = Pushbutton or contact for opening the circuit breaker
 V1 = Circuit breaker applications
 V4 = Indicative apparatus and connections for control and signaling, outside the circuit breaker
 XB.. = Three-way connector for the plug-in version circuit breaker auxiliary circuits
 XC.. = Six-way connector for the plug-in version circuit breaker auxiliary contacts
 XV = Terminal boxes of the circuit breaker applications
 YU = Undervoltage release (see note B)

Wiring diagrams of the accessories

Motor operator

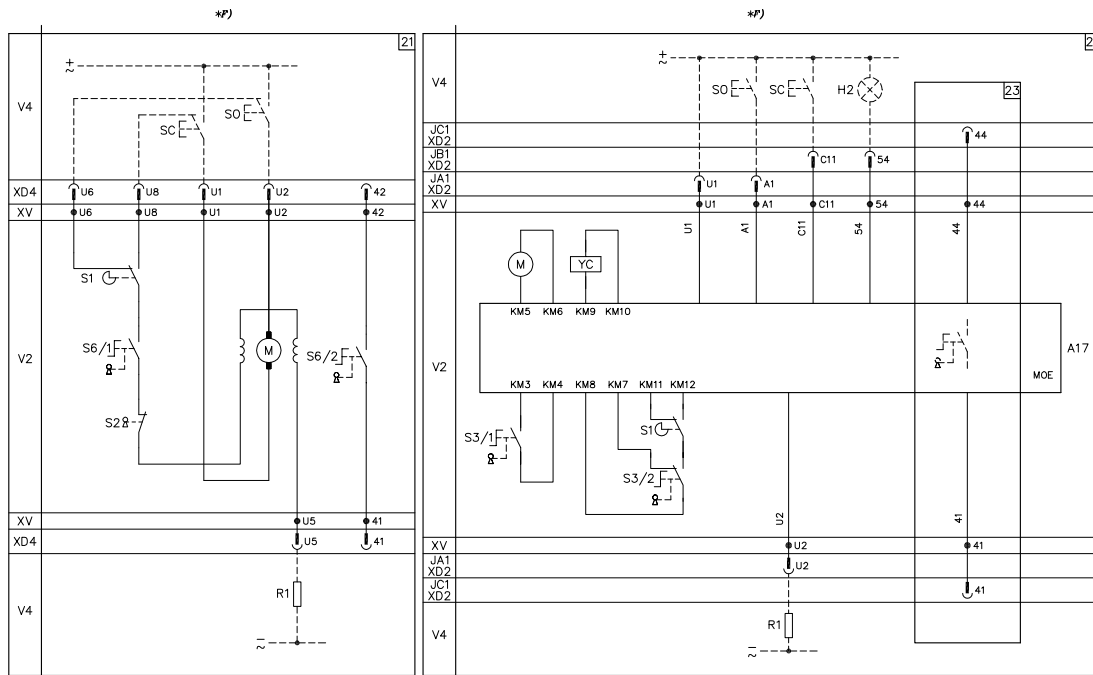

1SD021089D0001

Description of figures

- Fig. 21 = Direct control motor operator (MOD) (only for XT1 and XT3 fixed or plug-in circuit breakers) (see note I).
- Fig. 22 = Motor operator with stored energy (MOE) (only for circuit breakers XT2 and XT4).
- Fig. 23 = A contact for electrical signaling of stored energy motor operator that can be operated remotely.

Notes

- F) Additional external resistor for MOD and MOE supplied at 480/525V AC.

Caption

- = Diagram figure number
- * = See the note indicated by the letter
- A17 = Actuator unit type MOE for the stored energy motor operator
- H2 = Signaling lamp for stored energy motor operator blocked
- J.. = Connectors for the auxiliary contacts of the withdrawable version circuit breaker; extraction of the connectors takes place at the same time as that of the circuit breaker
- M = Motor with excitation in series for opening and closing the circuit breaker (fig. 21)
- M = Motor for opening the circuit breaker and spring charging for closing the circuit breaker (fig. 22)
- M1 = Three-phase asynchronous motor
- R1 = Resistor (see note F)
- S1 = Contact controlled by the cam of the motor operator
- S2 = Contact controlled by the key lock of the motor operator with direct action
- S3/1-2 = Contacts controlled by the Auto/Manual selector and key lock of the stored energy motor operator
- S4 = Contact controlled by the cam of the motor operator with direct action
- S6/1-2 = Contacts controlled by the Auto/Manual selector of the motor operator with direct action
- SC = Pushbutton or contact for closing the circuit breaker
- SO = Pushbutton or contact for opening the circuit breaker
- V2 = Motor operator applications
- V4 = Indicative apparatus and connections for control and signaling, outside the circuit breaker
- XD.. = Nine-way connector for the auxiliary circuits of the plug-in version circuit breaker
- XV = Terminal boxes of the circuit breaker applications
- YC = Shunt closing release of the stored energy motor operator

Signaling contacts

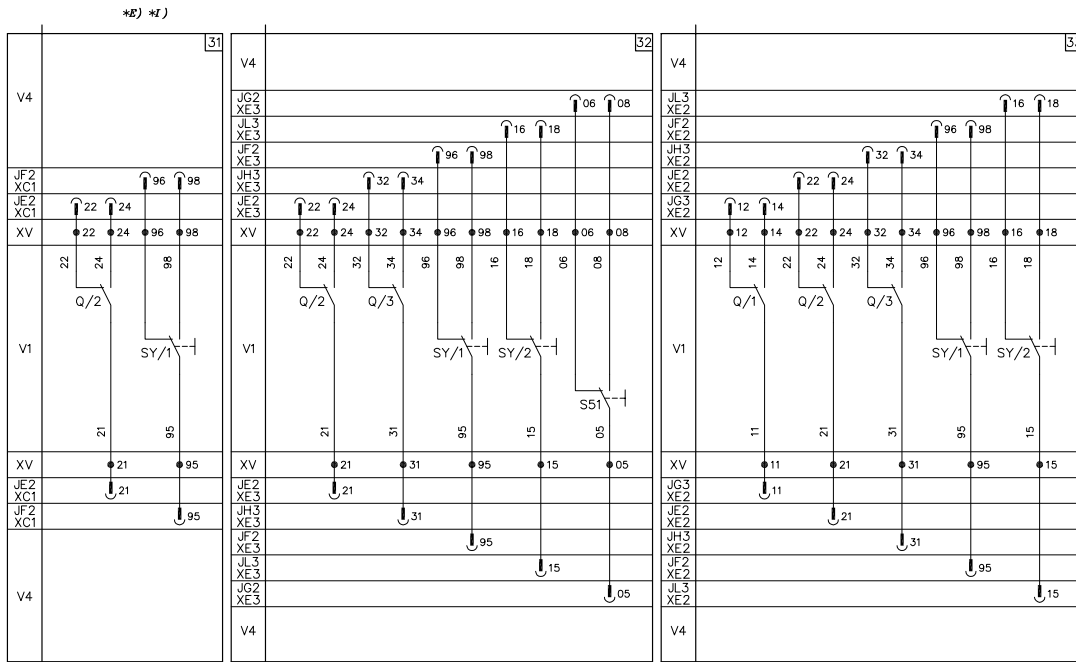

1SD021000EFC001

Description of figures

- Fig. 31 = One changeover contact for electrical signaling of circuit breaker open or closed and one changeover contact for electrical signaling of circuit breaker open due to tripping of the magnetic, thermomagnetic or electronic trip units, YO, YO1, YO2, YU (tripped position) (only for voltages up to 250V) (see notes E and I).
- Fig. 32 = Two changeover contacts for electrical signaling of circuit breaker open or closed, two changeover contacts for electrical signaling of circuit breaker open due to tripping of the magnetic, thermomagnetic or electronic trip units, YO, YO1, YO2, YU (tripped position) and one changeover contact for electrical signaling of circuit breaker open due to tripping of the thermomagnetic or electronic trip unit (only for voltages up to 250V).
- Fig. 33 = Three changeover contacts for electrical signaling of circuit breaker open or closed and two changeover contacts for electrical signaling of circuit breaker open due to tripping of the magnetic, thermomagnetic or electronic trip units, YO, YO1, YO2, YU (tripped position) (only for voltages up to 250V).

Notes

- E) The 24V auxiliary power supply unit of fig. 48 must be installed in the circuit breaker seats marked SY/1 and Q/2. Therefore, should you want to install the unit in fig. 48 and the contacts in fig. 31 at the same time, the contacts of fig. 31 must be installed in the adjacent slots; that is, contact SY/1 in the slot marked SY/2 and contact Q/2 in the slot marked Q/1.
- I) If the MOD (application in figure 21) and the auxiliary contacts 1Q+1SY (in figure 31) must be installed simultaneously, contact Q/2 must be installed in the slot marked as Q/1

Captions

- = Diagram figure number
- * = See the note indicated by the letter
- J.. = Connectors for the auxiliary contacts of the withdrawable version circuit breaker; connectors and circuit breaker are extracted simultaneously
- Q/0..3 = Circuit breaker auxiliary contacts
- S51 = Contact for electrical signaling of circuit breaker open due to tripping of the thermomagnetic or electronic trip unit
- SY/1..2 = Contacts for electrical signaling of circuit breaker open due to tripping of the thermomagnetic trip units, YO, YO1, YO2, YU (tripped position)
- V1 = Circuit breaker applications
- V4 = Indicative apparatus and connections for control and signaling, outside the circuit breaker
- XC.. = Six-way connector for the plug-in version circuit breaker auxiliary contacts
- XD.. = Nine-way connector for the auxiliary circuits of the plug-in version circuit breaker
- XE.. = Fifteen-way connector for the auxiliary circuits of the plug-in version circuit breaker
- XV = Terminal boxes of the circuit breaker applications

Wiring diagrams of the accessories

Signaling contacts

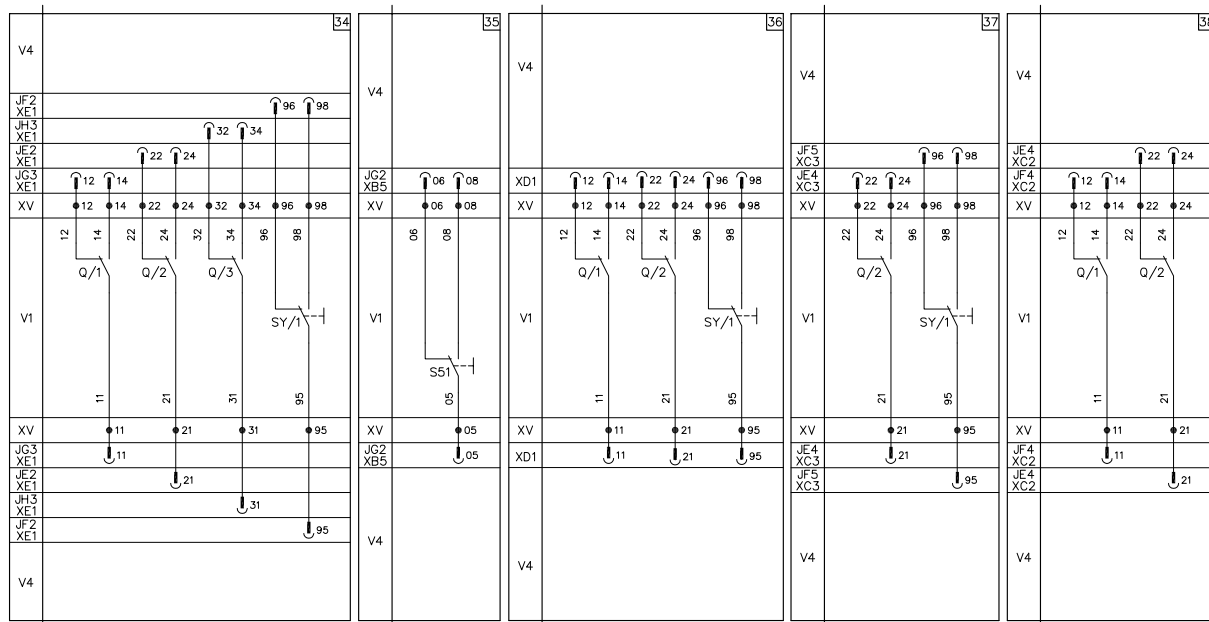

1SD021001EF0001

Description of figures

- Fig. 34 = Three changeover contacts for electrical signaling of circuit breaker open and one changeover contact for electrical signaling of circuit breaker open due to tripping of the magnetic, thermomagnetic or electronic trip units, YO, YO1, YO2, YU (tripped position) (only for voltages up to 250V).
- Fig. 35 = One changeover contact for electrical signaling of circuit breaker open due to tripping of the thermomagnetic electronic trip unit (only for voltages up to 250V).
- Fig. 36 = Two changeover contacts for electrical signaling of circuit breaker open or closed and one changeover contact for electrical signaling of circuit breaker open due to tripping of the magnetic, thermomagnetic or electronic trip units, YO, YO1, YO2, YU (tripped position) (only for voltages up to 250V).
- Fig. 37 = One changeover contact for electrical signaling of circuit breaker open or closed and one changeover contact for electrical signaling of circuit breaker open due to tripping of the magnetic, thermomagnetic or electronic trip units, YO, YO1, YO2, YU (tripped position) (only for voltage up to 400V).
- Fig. 38 = Two changeover contacts for electrical signaling of circuit breaker open or closed (only for voltage up to 400V).

Captions

- = Diagram figure number
- * = See the note indicated by the letter
- J.. = Connectors for the auxiliary contacts of the withdrawable version circuit breaker; connectors and circuit breaker are extracted simultaneously
- Q/0..3 = Circuit breaker auxiliary contacts
- S51 = Contact for electrical signaling of circuit breaker open due to tripping of the thermomagnetic or electronic trip unit
- SY/1 = Contacts for electrical signaling of circuit breaker open due to tripping of the thermomagnetic trip units, YO, YO1, YO2, YU (tripped position)
- V1 = Circuit breaker applications
- V4 = Indicative apparatus and connections for control and signaling, outside the circuit breaker
- XB.. = Three-way connector for the plug-in version circuit breaker auxiliary circuits
- XC.. = Six-way connector for the plug-in version circuit breaker auxiliary contacts
- XD.. = Nine-way connector for the auxiliary circuits of the plug-in version circuit breaker
- XE.. = Fifteen-way connector for the auxiliary circuits of the plug-in version circuit breaker
- XV = Terminal boxes of the circuit breaker applications

Signaling contacts

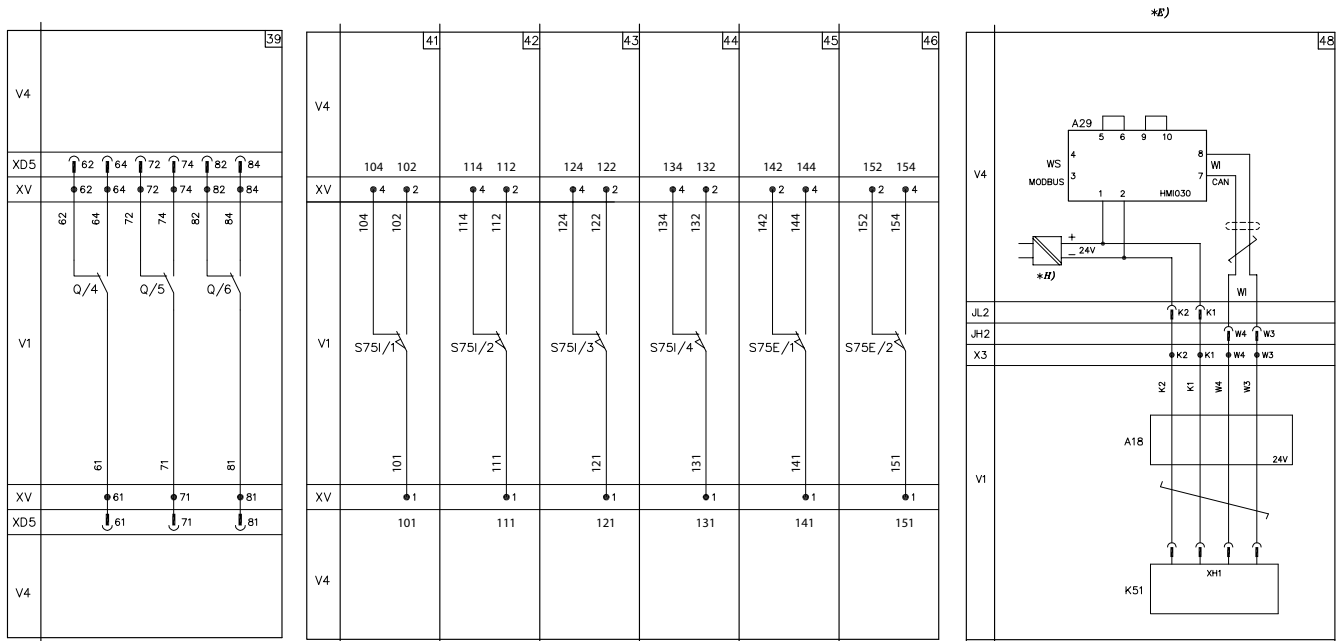

Description of figures

- Fig. 39 = Three supplementary changeover contacts for electrical signaling of circuit breaker open or closed (only for fixed or plug-in version circuit breakers).
- Fig. 41 = First changeover position contact of the circuit breaker, for electrical signaling of connected (only for plug-in or withdrawable version circuit breakers).
- Fig. 42 = Second changeover position contact of the circuit breaker, for electrical signaling of connected (only for plug-in or withdrawable version circuit breakers).
- Fig. 43 = Third changeover position contact of the circuit breaker, for electrical signaling of connected (only for plug-in or withdrawable version circuit breakers).
- Fig. 44 = Fourth changeover position contact of the circuit breaker, for electrical signaling of connected (only for plug-in or withdrawable version circuit breakers).
- Fig. 45 = First changeover position contact of the circuit breaker, for electrical signaling of isolated (only for withdrawable version circuit breakers).
- Fig. 46 = Second changeover position contact of the circuit breaker, for electrical signaling of isolated (only for withdrawable version circuit breakers).
- Fig. 48 = Auxiliary circuits of the 24V auxiliary power supply unit and of the HMI030 type interface unit (see note E).

Notes

- E) The 24V auxiliary power supply unit of fig. 48 must be installed in the circuit breaker seats marked SY/1 and Q/2. Therefore, should you want to install the unit in fig. 48 and the contacts in fig. 31 at the same time, the contacts of fig. 31 must be installed in the adjacent slots; that is, contact SY/1 in the slot marked SY/2 and contact Q/2 in the slot marked Q/1.
- H) Having requested a U_{aux} insulated from earth, “galvanically separated converters” must be used in compliance with IEC 60950 (UL 1950) or equivalent standards that ensure a common mode current or leakage current (see IEC 478/1, CEI 22/3) no greater than 3.5 mA, IEC 60364-41 and CEI 64-8.

Wiring diagrams of the accessories

Signaling contacts

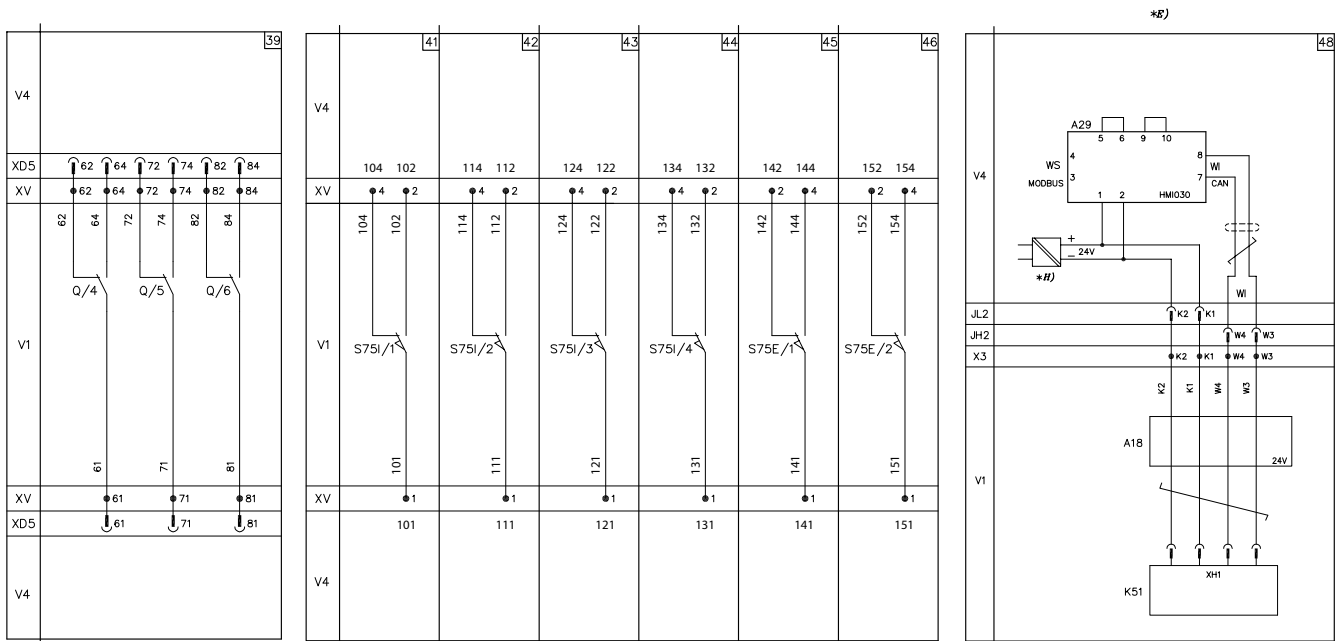

Captions

- = Diagram figure number
- * = See the note indicated by the letter
- J.. = Connectors for the auxiliary contacts of the withdrawable version circuit breaker; connectors and circuit breaker are extracted simultaneously
- K51 = Electronic trip unit:
 - of overcurrent type Ekip LS/I, Ekip N-LS/I, Ekip LSI, Ekip LSIg
 - of motor protection type Ekip I, Ekip M-I, Ekip M-LIU, Ekip M-LRIU
 - of generator protection type Ekip G-LSI
- Q/0..7 = Circuit breaker auxiliary contacts
- S75I/1..4 = Contacts for electrical signaling of circuit breaker in connected position (only provided with plug-in or withdrawable version circuit breakers)
- S75E/1-2 = Contacts for electrical signaling of circuit breaker in racked-out position (only provided with withdrawable version circuit breakers)
- V1 = Circuit breaker applications
- V4 = Indicative apparatus and connections for control and signaling, outside the circuit breaker
- WI = Serial interface with the trip unit accessories
- X3 = Connector of the circuit for the 24V auxiliary power supply unit
- XD.. = Nine-way connector for the auxiliary circuits of the plug-in version circuit breaker
- XV = Terminal boxes of the circuit breaker applications
- A18 = 24V auxiliary power supply unit (see note E)
- XH1 = Electronic trip unit contacts

Electronic trip unit Ekip E-LSIG connected with Ekip Display or Ekip LED Meter

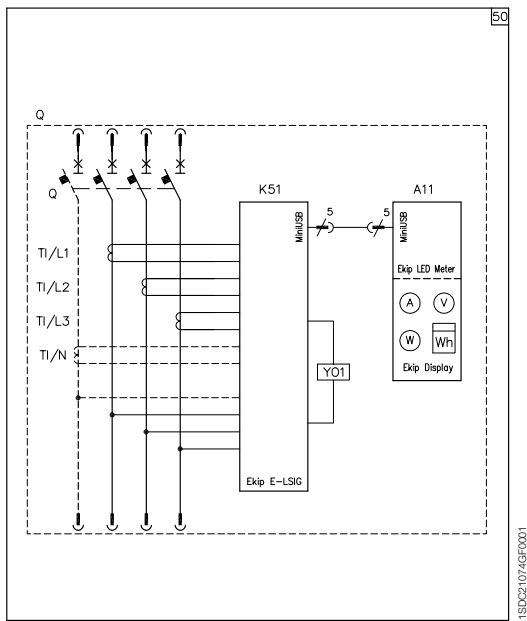

1SD021074GF0001

Description of figures

Fig. 50 = Auxiliary circuits of the Ekip E-LSIG microprocessor-based release connected to the Ekip Display (display) or Ekip LED Meter (current display) display unit.

Captions

- = Reference number of diagram figure
- A11 = Display unit type Ekip Display (display) or Ekip LED Meter (current display)
- K51 = Microprocessor-based release:
 - overcurrent release type Ekip I, Ekip LS/I, Ekip N-LS/I, Ekip LSI, Ekip LSIG, Ekip E-LSIG
 - motor protection release type Ekip M-LIU
- Q = Main switch
- TI/L1 = Current transformer located on phase L1
- TI/L2 = Current transformer located on phase L2
- TI/L3 = Current transformer located on phase L3
- TI/N = Current transformer located on neutral
- YO1 = Opening solenoid of microprocessor-based overcurrent release

Wiring diagrams of the accessories

Electronic trip unit Ekip LSI, Ekip LSIIG, Ekip LED Meter

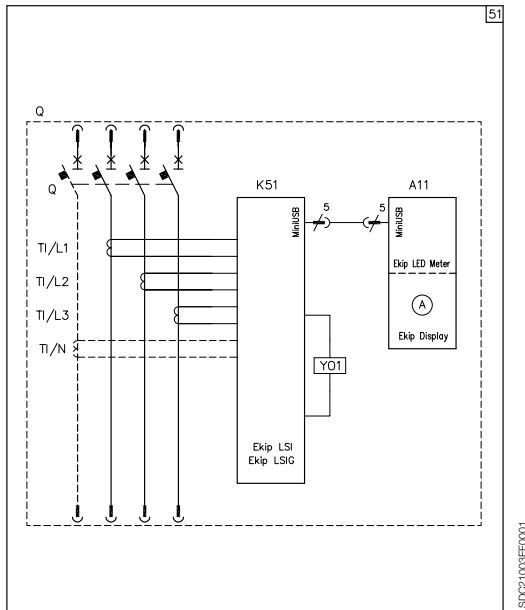

Description of figures

Fig. 51 = Auxiliary circuits of the electronic trip unit type Ekip LSI, Ekip LSIIG or Ekip MLRIU connected to display unit type Ekip Display (display) or Ekip LED Meter (current display).

Caption

- = Diagram figure number
- A11 = Display unit type Ekip Display (display) or Ekip LED Meter (current display)
- K51 = Microprocessor-based release:
 - overcurrent release type Ekip I, Ekip LS/I, Ekip N-LS/I, Ekip LSI, Ekip LSIIG, Ekip E-LSIG
 - motor protection release type Ekip M-LIU
- Q = Main circuit breaker
- TI/L1 = Current transformer placed on phase L1
- TI/L2 = Current transformer placed on phase L2
- TI/L3 = Current transformer placed on phase L3
- TI/N = Current transformer placed on the neutral
- YO1 = Opening solenoid of the microprocessor-based overcurrent release

Auxiliary circuit of Ekip-Com and HMI030

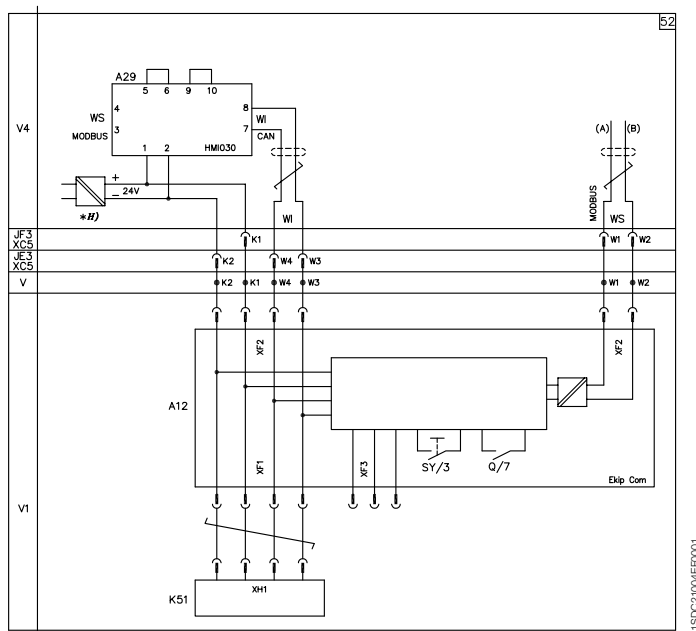

Description of figures

Fig. 52 = Auxiliary circuits of the Ekip Com type interface unit and of the HMI030 type interface unit (see note E).

Notes

H) Having requested a Uaux insulated from earth, “galvanically separated converters” must be used in compliance with IEC 60950 (UL 1950) or equivalent standards that ensure a common mode current or leakage current (see IEC 478/1, CEI 22/3) no greater than 3.5 mA, IEC 60364-41 and CEI 64-8.

Captions

- = Diagram figure number
- A12 = Interface unit type Ekip Com (with MODBUS serial communication)
- A13 = Signaling unit type LD030 DO
- K51 = Electronic trip unit:
 - of overcurrent type Ekip LSI, Ekip LSI G
- Q = Main circuit breaker
- Q/0..7 = Circuit breaker auxiliary contacts
- SY/1..3 = Contacts for electrical signaling of circuit breaker open due to tripping of the thermomagnetic trip units, YO, YO1, YO2, YU (tripped position)
- TI/L1 = Current transformer placed on phase L1
- TI/L2 = Current transformer placed on phase L2
- TI/L3 = Current transformer placed on phase L3
- TI/N = Current transformer placed on the neutral
- WI = Serial interface with the trip unit accessories
- WS = Serial interface with the control system (MODBUS EIA RS485 interface)
- XF = Connector of the Interface unit type Ekip Com
- XG-XH = Electronic trip unit connectors
- XV = Terminal boxes of the circuit breaker applications
- YO1 = Opening solenoid of the microprocessor-based overcurrent release

Wiring diagrams of the accessories

Electronic trip unit Ekip LSI, Ekip LSIG connected to interface unit Ekip Com and with actuator unit MOE-E for the stored energy motor operator

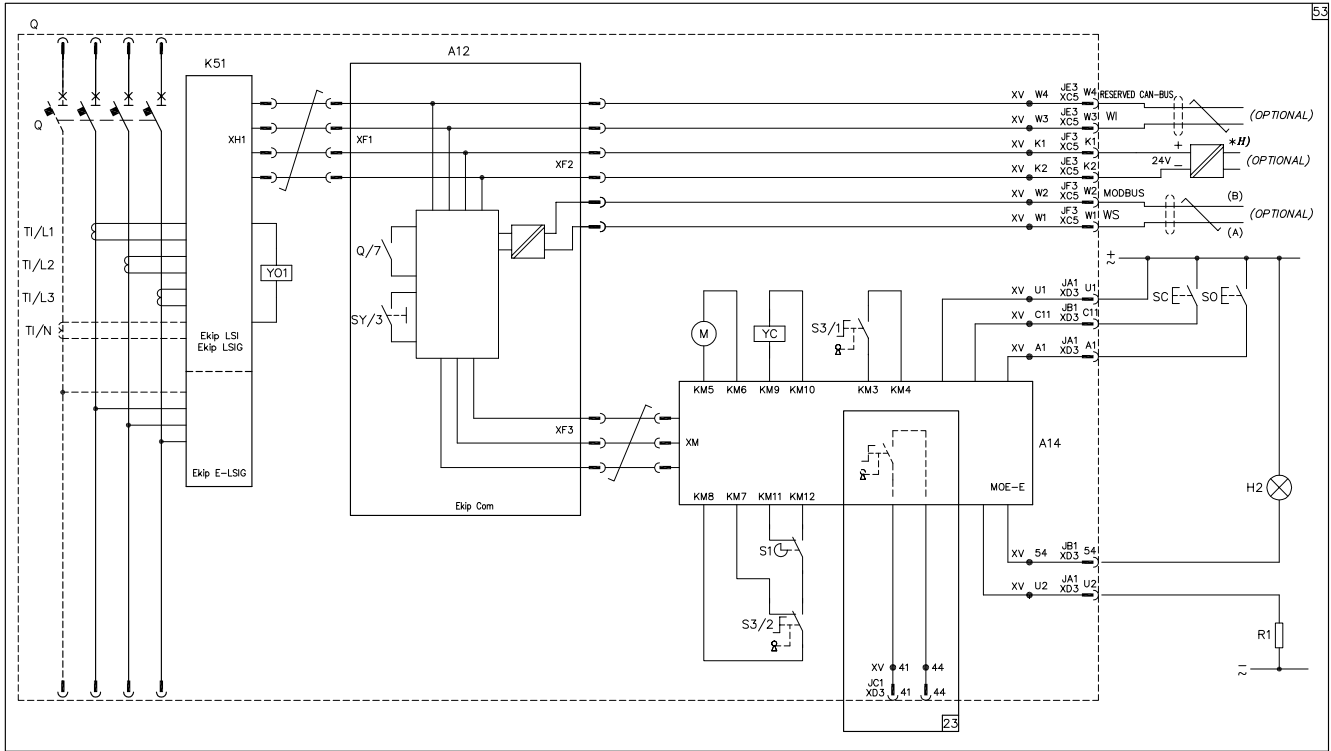

Description of figures

- Fig. 23 = One contact for electrical signaling of stored energy motor operator that can be operated remotely.
Fig. 53 = Auxiliary circuits of the electronic trip unit type Ekip LSI, Ekip LSI^G or Ekip M-LRIU connected to interface unit type Ekip Com and with actuator unit type MOE-E for the stored energy motor operator.

Notes

- H) Having requested a ground-insulated Uaux, "galvanically separated converters" must be used in compliance with IEC 60950 (UL 1950) or equivalent standards that ensure a common mode current or leakage current (see IEC 478/1, CEI 22/3) no greater than 3.5 mA, IEC 60364-41 and CEI 64-8.

Captions

- = Diagram figure number
A12 = Interface unit type Ekip Com (with MODBUS serial communication)
A14 = Actuator unit type MOE-E for the stored energy motor operator
H2 = Signaling lamp for blocked stored energy motor operator
J.. = Connectors for the auxiliary contacts of the withdrawable version circuit breaker; connectors and circuit breaker are extracted simultaneously
K51 = Electronic trip unit:
– of overcurrent type Ekip LSI, Ekip LSI^G
M = Motor with excitation in series for opening and closing the circuit breaker (fig. 21)
Q = Main circuit breaker
Q/0..7 = Circuit breaker auxiliary contacts
R1 = Resistor (see note H)
S1 = Contact controlled by the cam of the motor operator
S3/1-2 = Contacts controlled by the Auto/Manual selector and key lock of the stored energy motor operator
SC = Pushbutton or contact for closing the circuit breaker
SO = Pushbutton or contact for opening the circuit breaker
SY/1..3 = Contacts for electrical signaling of circuit breaker open due to tripping of the thermomagnetic trip units, YO, YO1, YO2, YU (tripped position)
TI = Toroidal current transformer
TI/L1 = Current transformer placed on phase L1
TI/L2 = Current transformer placed on phase L2
TI/L3 = Current transformer placed on phase L3
TI/N = Current transformer placed on the neutral
WI = Serial interface with the trip unit accessories
WS = Serial interface with the control system (MODBUS EIA RS485 interface)
XC.. = Six-way connector for the plug-in version circuit breaker auxiliary contacts
XD.. = Nine-way connector for the auxiliary circuits of the plug-in version circuit breaker
XF = Connector of the Interface unit type Ekip Com
XG-XH = Electronic trip unit connectors
XV = Terminal boxes of the circuit breaker applications
YC = Shunt closing release of the stored energy motor operator
YO1 = Opening solenoid of the microprocessor-based overcurrent release

Resetting instructions

Instructions for resetting the circuit breaker following release tripping

Selecting the type of circuit breaker resetting depends on design requirements and on service conditions.

Resetting can take place following tripping of the following releases:

- overcurrent;
- undervoltage;
- shunt opening.

The following three possibilities are suggested (see diagrams below):

1. Only manual resetting

To be wired (by the customer): contact SO1, contact SY/1 and the auxiliary relay KO (only for MOD).

Opening is prevented until the circuit breaker is in the tripped position.

To reset the circuit breaker it is necessary to activate the special lever on the front of the motor until the circuit breaker goes into the open position.

2. Electrical resetting making the operator responsible

To be wired (by the customer): contact SO1, SO2, contact SY/1 and the auxiliary relay KO (only for MOD).

Opening is allowed by means of contact S02, an operation entrusted to the person in charge of the control station provided that information has been received by same that enables tripping due to a short-circuit to be ruled out or if the causes of the short circuit have been eliminated/remedied.

3. Electrical resetting always allowed

To be wired (by the customer): contact SO1, SO2, contact SY/1 and the auxiliary relay KO (only for MOD).

Opening is always allowed by means of contact S02.

NB: If the magnetic, thermomagnetic or electronic trip unit is present, it is necessary to find the causes which led to the circuit breaker being in the tripped position so as to prevent reclosing under short-circuit conditions. In all cases, manual resetting is always allowed.

MOD

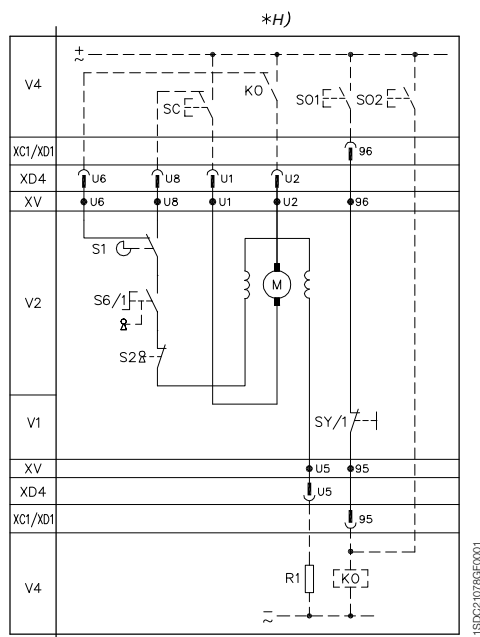

MOE or MOE-E

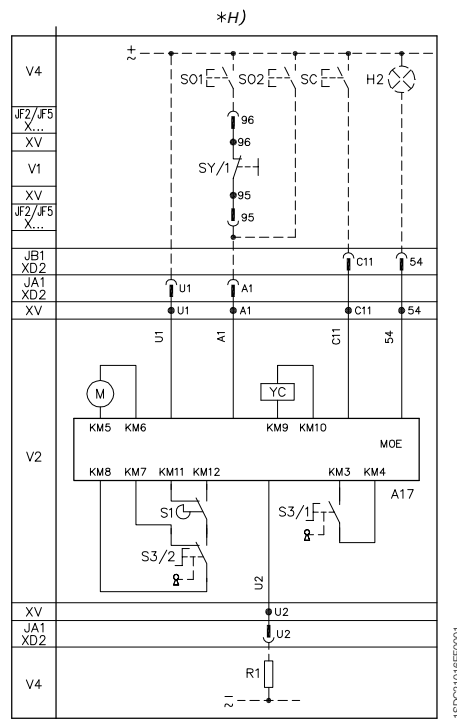

Notes

- H) Having requested a ground-insulated Uax, “galvanically separated converters” must be used, in compliance with IEC 60950 (UL 1950) or equivalent standards that ensure a common mode current or leakage current (see IEC 478/1, CEI 22/3) no greater than 3.5 mA, IEC 60364-41 and CEI 64-8.

Captions

- A17 = Actuator unit type MOE for the stored energy motor operator
H2 = Signaling lamp for blocked stored energy motor operator
J.. = Connectors for the auxiliary contacts of the withdrawable version circuit breaker; connectors and circuit breaker are extracted simultaneously
KO = Auxiliary opening relay
M = Motor with excitation in series for opening and closing the circuit breaker (fig. 21)
M = Motor for opening the circuit breaker and spring charging for closing the circuit breaker (fig. 22)
R1 = Resistor (see note H)
S1 = Contact controlled by the cam of the motor operator
S2 = Contact controlled by the key lock of the motor operator with direct action
S3/1-2 = Contacts controlled by the Auto/Manual selector and key lock of the stored energy motor operator
S6/1-2 = Contacts controlled by the Auto/Manual selector of the motor operator with direct action
SC = Pushbutton or contact for closing the circuit breaker
SO1,SO2 = Pushbuttons or contacts for opening the circuit breaker (see “Instructions for resetting the circuit breaker following release tripping”)
SY/1..3 = Contacts for electrical signaling of circuit breaker open due to tripping of the thermomagnetic trip units, YO, YO1, YO2, YU (tripped position)
V1 = Circuit breaker applications
V2 = Motor operator applications
V4 = Indicative apparatus and connections for control and signaling, outside the circuit breaker
XB.. = Three-way connector for the plug-in version circuit breaker auxiliary circuits
XC.. = Six-way connector for the plug-in version circuit breaker auxiliary contacts
XD.. = Nine-way connector for the auxiliary circuits of the plug-in version circuit breaker
XV = Terminal boxes of the circuit breaker applications
YC = Shunt closing release of the stored energy motor operator

Ordering codes

[Tmax XT part number explanation](#) 7/2

[Part numbers for XT1](#)

Circuit breakers	7/8
Accessories	7/10

[Part numbers for XT2](#)

Circuit breakers	7/17
Accessories	7/20

[Part numbers for XT3](#)

Circuit breakers	7/30
Accessories	7/32

[Part numbers for XT4](#)

Circuit breakers	7/39
Accessories	7/45

Instructions for ordering

Tmax XT order code explanation

Tmax XT Part number explanation

Configurator tool can be found at www.abb.us/lowvoltage-configurator

XT	2	L	U	3	125	G	F	F	E	E	D	X	X	X
1&2	3	4	5	6	7,8&9	10	11	12	13	14	15	16	17	18

1 & 2 - Tmax XT prefix, XT

3 - Frame size	
1	XT1 - to 125A, 600Y/347V (UL) / 160A, 690V (IEC) - Thermal magnetic protection
2	XT2 - to 125A, 600V (UL) / 160A (IEC), 690V - Thermal magnetic and electronic protection
3	XT3 - to 225A, 600Y/347V (UL) / 250A, 690V (IEC) - Thermal magnetic protection
4	XT4 - to 250A, 600V (UL) / 250A, 690V (IEC) - Thermal magnetic and electronic protection

4 - Breaking capacity

	B	C	N	S	H	L	V	X
UL kA @ 480V	-	-	25	35	65	100	150	200
UL kA @ 600Y/347V	-	-	18/10 ⁽¹⁾	22/10 ⁽¹⁾	25	-	-	-
UL kA @ 600V	-	-	18	22	25	35/50 ⁽²⁾	42/65 ⁽²⁾	42/100/65 ⁽²⁾
IEC kA @ 415V	18	25	36	50	70	120	150	-

⁽¹⁾Breaking capacities are 18(N) and 22(S) for XT1 and 10 (N&S) for XT3.

⁽²⁾Breaking capacities are 35 (L) and 42 (V&X) for XT2 and 50 (L), 65 (V) for XT4 with X at 100 to 150A and 65 to 250A.

Note: H, L and V breaking capacities for XT2 and XT4 UL are Current Limiting.

5 - Standard

		+ CCC Mark
UL 80% rated / IEC dual rated	U	C
UL 100% rated / IEC dual rated	Q	L
IEC only / use only for IEC specific needs	E	R
IEC for 50°C	5	-

6 - Number of poles

2	2 Poles (XT4 N UL version only)
3	3 Poles
4	4 Poles, 100% Neutral
N	4 Poles 50% Neutral (IEC, TMD/TMA over 100A only)

7-9 - Nominal current

UL Circuit Breakers	10A	15A	20A	25A	30A	35A	40A	45A	50A	60A	70A	
XT1	TMF	-	015	020	025	030	035	040	045	050	060	070
XT2	TMF/TMA ⁽¹⁾	-	015	020	025	030	035	040	-	050	060	070
	Ele	010	-	-	025	-	-	-	-	060	-	-
XT3	TMF	-	-	-	-	-	-	-	-	060	070	
XT4	TMF/TMA ⁽²⁾	-	-	-	025	030	035	040	-	050	060	070
	Ele	-	-	-	-	-	040	-	-	060	-	-
		80A	90A	100A	110A	125A	150A	175A	200A	225A	250A	
XT1	TMF	080	090	100	110	125	-	-	-	-	-	
XT2	TMF/TMA ⁽¹⁾	080	090	100	110	125	-	-	-	-	-	
	Ele	-	-	100	-	125	-	-	-	-	-	
XT3	TMF	080	090	100	110	125	150	175	200	225	-	
XT4	TMF/TMA ⁽²⁾	080	090	100	110	125	150	175	200	225	250	
	Ele	-	-	100	-	-	150	-	-	225	250	

⁽¹⁾Tmax XT2 are thermal magnetic fixed through 70A and thermal magnetic adjustable for 80A and higher.

⁽²⁾Tmax XT4 are thermal magnetic fixed through 70A for all pole versions. 80A and higher 2-pole versions have thermal magnetic fixed. 3-pole versions have both thermal magnetic fixed and adjustable options and 4-pole versions have thermal magnetic adjustable.

UL Motor Protection		3A	7A	15A	25A	30A	40A	50A	60A	70A
XT1	MCP (MA)	003	007	015	-	030	-	050	-	070
XT2	MCP (MA)	003	007	015	-	030	-	050	-	070
	M-LIU	-	-	-	025	-	-	-	060	-
XT3	MCP (MA)	-	-	-	-	-	-	-	-	-
XT4	MCP (MA)	-	-	-	025	-	-	050	-	-
	M-LIU	-	-	-	-	-	040	-	060	-
		80A	100A	110A	125A	150A	175A	200A	225A	250A
XT1	MCP (MA)	080	100	-	125	-	-	-	-	-
XT2	MCP (MA)	080	100	-	125	-	-	-	-	-
	M-LIU	-	100	-	-	-	-	-	-	-
XT3	MCP (MA)	-	100	110	125	150	-	200	-	-
XT4	MCP (MA)	080	100	110	125	150	175	200	225	250
	M-LIU	-	100	-	-	150	-	-	-	-

UL Switches		125A	225A	250A						
XT1	MCS	125	-	-						
XT2	MCS	125	-	-						
XT3	MCS	-	225	-						
XT4	MCS	-	-	250						

IEC Circuit Breakers		4A	5A	8A	10A	16A	20A	25A	32A	40A
XT1	TMD	-	-	-	-	016	020	025	032	040
XT2	TMD/TMA ⁽¹⁾	004	005	008	010	016	020	025	032	040
	Ele	-	-	-	010	-	-	025	-	-
XT3	TMD	-	-	-	-	-	-	-	-	-
XT4	TMD/TMA ⁽¹⁾	-	-	-	-	016	020	025	032	040
	Ele	-	-	-	-	-	-	-	-	040
		50A	63A	80A	100A	125A	160A	200A	225A	250A
XT1	TMD	050	063	080	100	125	160	-	-	-
XT2	TMD/TMA ⁽¹⁾	050	063	080	100	125	160	-	-	-
	Ele	-	063	-	100	-	160	-	-	-
XT3	TMD	-	063	080	100	125	160	200	-	250
XT4	TMD/TMA ⁽¹⁾	050	063	080	100	125	160	200	225	250
	Ele	-	063	-	100	-	160	-	-	250

⁽¹⁾Tmax XT2 and XT4 IEC are thermal magnetic with adjustable overload and fixed instantaneous through 32A and thermal magnetic adjustable for 40A and higher.

IEC Motor Protection		1A	2A	4A	10A	20A	32A	52A	80A	100A
XT2	MF/MA	001	002	004	-	020	032	052	080	100
	MI	-	-	-	-	020	032	052	-	100
XT3	MA	-	-	-	-	-	-	-	-	100
XT4	MA	-	-	-	010	020	032	052	080	100
		125A	160A	200A						
XT2	MF/MA	-	160	-						
	MI	-	-	-						
XT3	MA	125	160	200						
XT4	MA	125	160	200						

Part number explanation

IEC Switches		160A	250A							
XT1	MCS	160	-							
XT3	MCS	-	250							
XT4	MCS	-	250							

IEC Generator Protection		16A	20A	25A	32A	40A	50A	63A	80A	100A	125A
XT2	TMG	016	020	025	032	040	050	063	080	100	125
XT3	TMG	-	-	-	-	-	-	063	080	100	125

		160A	200A	250A						
XT2	TMG	160	-	-						
XT3	TMG	160	200	250						

10 - Trip unit

A	Thermal magnetic fixed (TMF)
B	Thermal magnetic adjustable (TMD/TMA)
D	Molded case switch disconnecter
E	Ekip LS/I (Electronic, LS/I protection)
F	Ekip LSI (Electronic, LSI protection)
G	Ekip LSIG (Electronic, LSIG protection)
H	Ekip E-LSIG (Electronic, LSIG plus measurements)
J	Ekip I (Electronic, Instantaneous trip only)
K	Ekip M-I (Electronic Motor Protector, I protection) (IEC only)
L	Ekip M-LIU (Electronic Motor Protector with integrated overload and phase loss detection) (UL only)
M	Motor circuit protector (MCP - magnetic only) (MA/MF)
N	Thermal magnetic generator protection (TMG) (IEC only)

11 - Line side termination (top)

F	F Front terminals, no lugs installed
A	FC Cu Terminals for Cu cables (Saddle Clamps)
B	FC CuAl Terminals for CuAl cables, 14-1/0 AWG, 110A (UL XT2) ⁽¹⁾
G	FC CuAl Terminals for CuAl cables, 14-1/0 AWG, 100A (UL XT3, UL XT4) ⁽²⁾
H	FC CuAl Terminals for CuAl cables, 14-1/0 AWG, 100A, Control Tap Included (UL XT3, UL XT4) ⁽¹⁾⁽²⁾
J	FC CuAl Terminals for CuAl cables, 4 AWG-300 kcmil, 225A (UL XT3, UL XT4) ⁽²⁾
K	FC CuAl Terminals for CuAl cables, 4 AWG-300 kcmil, 225A, Control Tap Included (UL XT3, UL XT4) ⁽¹⁾⁽²⁾
L	FC CuAL Terminals for CuAl Cables, 250-350 kcmil, 250A (UL XT4) ⁽¹⁾⁽²⁾
Z	MC Multi-cable terminals for Cu (6 wire)
1	EF Extended front terminals
2	ES Extended spread terminals
3	FB Terminals for flexible busbar (IEC only)
4	R Rear terminals (IEC only)
5	Panel board Adapter ⁽¹⁾
6	Plug-in kit (Must also use 6 for load side)
7	Withdrawable kit - XT2 & XT4 only (Must also use 7 for the load side)

⁽¹⁾Product is in development. Contact ABB for availability.

⁽²⁾Not available for XT4 X version to 150A.

Note: Additional terminal options are available as loose accessories for IEC versions. Please see the IEC catalog for more details.

12 - Load side termination (bottom)

F	F Front terminals, no lugs installed
A	FC Cu Terminals for Cu cables (Saddle Clamps)
B	FC CuAl Terminals for CuAl cables, 14-1/0 AWG, 110A (UL XT2) ⁽¹⁾
G	FC CuAl Terminals for CuAl cables, 14-1/0 AWG, 100A (UL XT3, UL XT4) ⁽²⁾
H	FC CuAl Terminals for CuAl cables, 14-1/0 AWG, 100A, Control Tap Included (UL XT3, UL XT4) ⁽¹⁾⁽²⁾
J	FC CuAl Terminals for CuAl cables, 4 AWG-300 kcmil, 225A (UL XT3, UL XT4) ⁽²⁾
K	FC CuAl Terminals for CuAl cables, 4 AWG-300 kcmil, 225A, Control Tap Included (UL XT3, UL XT4) ⁽¹⁾⁽²⁾
L	FC CuAl Terminals for CuAl Cables, 250-350 kcmil, 250A (UL XT4) ⁽¹⁾⁽²⁾
Z	MC Multi-cable terminals for Cu (6 wire)
1	EF Extended front terminals
2	ES Extended spread terminals
3	FB Terminals for flexible busbar (IEC only)
4	R Rear terminals (IEC only)
6	Plug-in kit (Must also use 6 for line side)
7	Withdrawable kit - XT2 & XT4 only (Must also use 7 for the line side)

⁽¹⁾Product is in development. Contact ABB for availability.

⁽²⁾Not available for XT4 X version to 150A.

Note: Additional terminal options are available as loose accessories for IEC versions. Please see the IEC catalog for more details.

13 - Internal accessories - left of mechanism

0	None
A	SOR Shunt trip 12V DC
B	SOR Shunt trip 24-30V AC/DC
C	SOR Shunt trip 48-60V AC/DC
D	SOR Shunt trip 110-127V AC / 110-125V DC
E	SOR Shunt trip 220-240V AC / 220-250V DC
F	SOR Shunt trip 380-440V AC
G	SOR Shunt trip 480-525V AC
Z	AUX 3Q 250V AC/DC (not available for withdrawable)
1	UVR Undervoltage release 24-30V AC/DC
2	UVR Undervoltage release 48V AC/DC
3	UVR Undervoltage release 60V AC/DC
4	UVR Undervoltage release 110-127V AC 110-125V DC
5	UVR Undervoltage release 220-240V AC 220-250V DC
6	UVR Undervoltage release 380-440V AC
7	UVR Undervoltage release 480-525V AC

Note: A second option for the left side of the mechanism is available on a 4-pole circuit breaker as a loose accessory.

Part number explanation

14 - Internal accessories - right of mechanism

0	None
A	AUX 1Q, 1SY 250V AC/DC
B	AUX 2Q, 1SY 250V AC/DC (not available for withdrawable)
C	AUX 3Q, 1SY 250V AC/DC (not available for XT1)
D	AUX 3Q, 2SY 250V AC/DC (XT2, XT4)
E	AUX 2Q, 2SY, 1 S51 250V AC/DC (XT2, XT4)
F	AUX 1 S51 250V AC/DC (XT2, XT4)
G	AUX 1Q, 1SY 24V DC
H	AUX 3Q, 1SY 24V DC (not available for XT1)
J	AUX 1 S51 24V DC (XT2, XT4)
K	AUX 1Q, 1SY 400V AC (XT2, XT4 not compatible with other right side AUX)
L	AUX 2Q 400V AC (XT2, XT4 not compatible with other right side AUX)
1	Ekip Com (XT2, XT4, not compatible with other right side AUX)
2	Ekip Com + Aux 1S51 24V DC (XT2, XT4, not compatible with other right side AUX)
3	Ekip Com + Aux 1S51 250V AC/DC (XT2, XT4, not compatible with other right side AUX)

7

15 - Front accessories

0	None
A	Motor operator 24V DC
B	Motor operator 48-60V DC
C	Motor operator 110-125V AC/DC
D	Motor operator 220-250V AC/DC
E	Motor operator 380-440V AC
F	Motor operator 480 - 525V AC
G	PLL Fixed padlock device in open/closed position
H	PLL Fixed padlock device in open position
J	PLL Removable padlock device in open position (XT1, XT3)
K	FLD Front for locking operating lever mechanism (XT2, XT4)
L	RHD Normal direct handle
M	RHD Emergency direct handle
N	RHE Variable depth mechanism, standard
P	RHE Variable depth mechanism, with padlock
Q	RHD Normal direct handle + Early Aux contact, opening
R	RHD Emergency direct handle + Early Aux contact, opening
S	RHE Variable depth mechanism, standard + Early Aux contact, opening
T	RHE Variable depth mechanism, with padlock + Early Aux Contact, opening
U	RHD Normal direct handle + Early Aux contact, closing
V	RHD Emergency direct handle + Early Aux contact, closing
W	RHE Variable depth mechanism, standard + Early Aux contact, closing
X	RHE Variable depth mechanism, with padlock + Early Aux Contact, closing
1	Motor operator for use with Modbus 24V DC (IEC only)
2	Motor operator for use with Modbus 48-60V DC (IEC only)
3	Motor operator for use with Modbus 110-125V AC/DC (IEC only)
4	Motor operator for use with Modbus 220-250V AC/DC (IEC only)
5	Motor operator for use with Modbus 380-440V AC (IEC only)
6	Motor operator for use with Modbus 480 - 525V AC (IEC only)

16 - Key locks

X	None
A	Ronis key lock, open position - A type
B	Ronis key lock, open position - B type
C	Ronis key lock, open position - C type
D	Ronis key lock, open position - D type
E	Ronis key lock, open position - different keys
F	Ronis key lock, open/closed - different keys (not available for motors)

Note: Key locks are available for placement on the circuit breaker, on rotary handle mechanisms or on motors. Key locks for motors are IEC only.

17 - For future use

X	None
----------	------

18 - Additional certifications

X	None			
		3yr warranty	4yr warranty	5yr warranty
		3	4	5
Test certificate provided (in English)	E	A	B	C
Test certificate provided (in French)	F	G	H	J
Test certificate provided (in Spanish)	S	K	L	M

Note: Extended warranty options require additional paperwork to be completed per order.

Ordering codes for XT1 UL/CSA Circuit breakers

XT1 125A TMF - Fixed (F) - 3 poles - Front terminals (F) - UL/CSA

Thermal magnetic trip unit			Int Rtnng (480V)	N 25kA Part number	S 35kA Part number	H 65kA Part number
Type	In	I ₃				
TMF	15	500		XT1NU3015AFF000XXX	XT1SU3015AFF000XXX	XT1HU3015AFF000XXX
	20	500		XT1NU3020AFF000XXX	XT1SU3020AFF000XXX	XT1HU3020AFF000XXX
	25	500		XT1NU3025AFF000XXX	XT1SU3025AFF000XXX	XT1HU3025AFF000XXX
	30	500		XT1NU3030AFF000XXX	XT1SU3030AFF000XXX	XT1HU3030AFF000XXX
	35	500		XT1NU3035AFF000XXX	XT1SU3035AFF000XXX	XT1HU3035AFF000XXX
	40	500		XT1NU3040AFF000XXX	XT1SU3040AFF000XXX	XT1HU3040AFF000XXX
	45	500		XT1NU3045AFF000XXX	XT1SU3045AFF000XXX	XT1HU3045AFF000XXX
	50	500		XT1NU3050AFF000XXX	XT1SU3050AFF000XXX	XT1HU3050AFF000XXX
	60	600		XT1NU3060AFF000XXX	XT1SU3060AFF000XXX	XT1HU3060AFF000XXX
	70	700		XT1NU3070AFF000XXX	XT1SU3070AFF000XXX	XT1HU3070AFF000XXX
	80	800		XT1NU3080AFF000XXX	XT1SU3080AFF000XXX	XT1HU3080AFF000XXX
	90	900		XT1NU3090AFF000XXX	XT1SU3090AFF000XXX	XT1HU3090AFF000XXX
	100	1000		XT1NU3100AFF000XXX	XT1SU3100AFF000XXX	XT1HU3100AFF000XXX
	110	1100		XT1NU3110AFF000XXX	XT1SU3110AFF000XXX	XT1HU3110AFF000XXX
	125	1250		XT1NU3125AFF000XXX	XT1SU3125AFF000XXX	XT1HU3125AFF000XXX

7

XT1 125A TMF - Fixed (F) - 4 poles - Front terminals (F) - UL/CSA

Thermal magnetic trip unit			Int Rtnng (480V)	N 25kA Part number	S 35kA Part number	H 65kA Part number
Type	In	I ₃				
TMF	15	500		XT1NU4015AFF000XXX	XT1SU4015AFF000XXX	XT1HU4015AFF000XXX
	20	500		XT1NU4020AFF000XXX	XT1SU4020AFF000XXX	XT1HU4020AFF000XXX
	25	500		XT1NU4025AFF000XXX	XT1SU4025AFF000XXX	XT1HU4025AFF000XXX
	30	500		XT1NU4030AFF000XXX	XT1SU4030AFF000XXX	XT1HU4030AFF000XXX
	35	500		XT1NU4035AFF000XXX	XT1SU4035AFF000XXX	XT1HU4035AFF000XXX
	40	500		XT1NU4040AFF000XXX	XT1SU4040AFF000XXX	XT1HU4040AFF000XXX
	45	500		XT1NU4045AFF000XXX	XT1SU4045AFF000XXX	XT1HU4045AFF000XXX
	50	500		XT1NU4050AFF000XXX	XT1SU4050AFF000XXX	XT1HU4050AFF000XXX
	60	600		XT1NU4060AFF000XXX	XT1SU4060AFF000XXX	XT1HU4060AFF000XXX
	70	700		XT1NU4070AFF000XXX	XT1SU4070AFF000XXX	XT1HU4070AFF000XXX
	80	800		XT1NU4080AFF000XXX	XT1SU4080AFF000XXX	XT1HU4080AFF000XXX
	90	900		XT1NU4090AFF000XXX	XT1SU4090AFF000XXX	XT1HU4090AFF000XXX
	100	1000		XT1NU4100AFF000XXX	XT1SU4100AFF000XXX	XT1HU4100AFF000XXX
	110	1100		XT1NU4110AFF000XXX	XT1SU4110AFF000XXX	XT1HU4110AFF000XXX
	125	1250		XT1NU4125AFF000XXX	XT1SU4125AFF000XXX	XT1HU4125AFF000XXX

XT1 125A MCP (MA) Fixed (F) - 3 poles - Front terminals (F) - UL/CSA

Magnetic trip unit			Int Rtnng (480V)	H 65kA Part number
Type	In	I ₃		
MCP	3	9...33		XT1HU3003MFF000XXX
	7	21...77		XT1HU3007MFF000XXX
	15	45...165		XT1HU3015MFF000XXX
	30	90...330		XT1HU3030MFF000XXX
	50	150...550		XT1HU3050MFF000XXX
	70	210...770		XT1HU3070MFF000XXX
	80	240...880		XT1HU3080MFF000XXX
	100	300...1100		XT1HU3100MFF000XXX
	125	375...1375		XT1HU3125MFF000XXX

XT1 125A Switch - Fixed (F) - 3 poles - Front terminals (F) - UL/CSA

No Trip Unit			Int Rtnng (480V)	N 25kA Part number	S 35kA Part number	H 65kA Part number		
Type	In	Mag. Override						
D	125	1000		XT1NU3125DFF000XXX	XT1SU3125DFF000XXX	XT1HU3125DFF000XXX		

XT1 125A Switch - Fixed (F) - 4 poles - Front terminals (F) - UL/CSA

No Trip Unit			Int Rtnng (480V)	N 25kA Part number	S 35 kA Part number	H 65k Part number		
Type	In	Mag. Override						
D	125	1000		XT1NU4125DFF000XXX	XT1SU4125DFF000XXX	XT1HU4125DFF000XXX		

Ordering codes for XT1 UL/CSA Accessories

Fixed parts, conversion kits and accessories for fixed parts



Fixed part of plug-in

Fixed part of plug-in (P)

Type	3p Part number	4p Part number		
Kit P FP EF	KXT1PFPEF-3	KXT1PFPEF-4		
Kit P FP HR/VR ⁽¹⁾	KXT1EPFPHR-3	KXT1EPFPHR-4		

⁽¹⁾IEC rated only. The terminals are factory-mounted in the horizontal position (HR).

Terminals for the fixed parts⁽¹⁾

Type	3p Part number	4p Part number		
EF - Front extended terminals	KXT1EEFFP-3	KXT1EEFFP-4		
R - Rear terminals HR/VR	KXT1ERFP-3	KXT1ERFP-4		
PS - Rear phase separators 90mm/3.54in	KXTAEPB90-3	KXTAEPB90-4		

⁽¹⁾IEC rated only.

7



Conversion kit

Conversion kit of the circuit breaker from fixed into moving part of plug-in

Type	3p Part number	4p Part number		
P MP kit	KXT1PMP-3	KXT1PMP-4		



Fixed part adapter

Adapter for mounting the terminals of the fixed circuit breaker on the fixed part

Type	3p Part number	4p Part number		
ADP adapter for fixed part (2 pieces)	KXT1ADP-3	KXT1ADP-4		

Note: When using ADP with ES/MC terminals, also order "Kit F Front Terminals".

Service releases

Shunt Trip - SOR



SOR uncabled



SOR cabled

Type	Part number			
Uncabled version				
SOR 12V DC	KXTASORA			
SOR 24-30V AC/DC	KXTASORB			
SOR 48-60V AC/DC	KXTASORC			
SOR 110...127V AC / 110...125V DC	KXTASORD			
SOR 220...240V AC / 220...250V DC	KXTASORE			
SOR 380-440V AC	KXTASORF			
SOR 480-525V AC	KXTASORG			
Cabled version				
SOR-C 12V DC	KXTASORCFPA			
SOR-C 24-30V AC/DC	KXTASORCFPB			
SOR-C 48-60V AC/DC	KXTASORCFPC			
SOR-C 110...127V AC / 110...125V DC	KXTASORCFPD			
SOR-C 220...240V AC / 220...250V DC	KXTASORCFPE			
SOR-C 380-440V AC	KXTASORCFPF			
SOR-C 480-525V AC	KXTASORCFPG			

Undervoltage release - UVR



UVR uncabled



UVR cabled

Type	Part number			
Uncabled version				
UVR 24-30V AC/DC	KXTAUVR1			
UVR 48V AC/DC	KXTAUVR2			
UVR 60V AC/DC	KXTAUVR3			
UVR 110...127V AC / 110...125V DC	KXTAUVR4			
UVR 220...240V AC / 220...250V DC	KXTAUVR5			
UVR 380-440V AC	KXTAUVR6			
UVR 480-525V AC	KXTAUVR7			
Cabled version				
UVR-C 24-30V AC/DC	KXTAUVRCPF1			
UVR-C 48V AC/DC	KXTAUVRCPF2			
UVR-C 60V AC/DC	KXTAUVRCPF3			
UVR-C 110...127V AC / 110...125V DC	KXTAUVRCPF4			
UVR-C 220...240V AC / 220...250V DC	KXTAUVRCPF5			
UVR-C 380-440V AC	KXTAUVRCPF6			
UVR-C 480-525V AC	KXTAUVRCPF7			

Delay device for undervoltage release - UVD⁽¹⁾



Time delay device for undervoltage release

Type	Part number			
UVD 24...30V AC/DC	KT3UVD8			
UVD 48...60V AC/DC	KT3UVD7			
UVD 110...125V AC/DC	KT3UVD4			
UVD 220...250V AC/DC	KT3UVD2			

⁽¹⁾IEC rated only.

Ordering codes for XT1 UL/CSA Accessories



Socket plug connector

Connectors

Socket plug connector on the panel⁽¹⁾

Type	Part number			
Socket-plug connector with 3 PINS	KXTAE3PINCON			
Socket-plug connector with 6 PINS	KXTAE6PINCON			
Socket-plug connector with 9 PINS	KXTAE9PINCON			
Socket-plug connector with 15 PINS	KXTAE15PINCON			

⁽¹⁾IEC rated only.



AUX uncabled



AUX cabled

Electrical signals

Auxiliary contacts - AUX

Type	Part number			
Uncabled version				
AUX 250V	KXTAAUX			
AUX 24V DC	KXTAAUXD			
Cabled version				
AUX-C 3 Q 250V Left	KXT1AXC3QL			
AUX-C 1 Q +1 SY 250V	KXTAAXCQSYFP			
AUX-C 2 Q +1 SY 250V	KXTAAXC2QSYFP			
AUX-C 1 Q +1 SY 24V DC	KXTAAXCDQSYFP			

Auxiliary position contacts - AUP

Type	Part number			
Cabled version				
AUP-I – Four racked-in contacts 250V for plug-in circuit breaker	KXTAAUP250IN			
AUP-I – Four racked-in contacts 24V DC for plug-in circuit breaker	KXTAAUP24IN			



AUP - Auxiliary position contacts



AUE - Early auxiliary contacts

Early auxiliary contacts - AUE

Type	Part number			
AUE – Two contacts in the rotary handle RHx (Closed)	KXTAAUECLFP			
AUE – Two contacts in the rotary handle RHx (Open)	KXTDAUEOPFP			

Motor operators

Motor operator with direct action - MOD

Type	Part number			
MOD 24V DC	KXTBMOD24			
MOD 48...60V DC	KXTBMOD48-60			
MOD 110...125V AC/DC	KXTBMOD110-125			
MOD 220...250V AC/DC	KXTBMOD220-250			
MOD 380...440V AC	KXTBMOD280-240			
MOD 480...525V AC	KXTBMOD480-525			



Motor operator

Rotary handle operating mechanisms



Direct rotary handle



Extended rotary handle



IP54

Rotary handle operating mechanism

Type	Part number			
RHD Standard Direct Handle	KXTBRHDSTFP			
RHD Emergency Direct Handle	KXTBRHDEMFP			
RHE Standard Extended Handle	KXTBRHESTFP			
RHE Emergency Extended Handle	KXTBRHEEMFP			
RHE Standard Extended Handle with Padlock ⁽¹⁾	KXTBRHESTFPPLK			
RHE Emergency Extended Handle with Padlock ⁽¹⁾	KXTBRHEEMFPPLK			
RHS-L Standard Left Side Handle	KXTBRHSLSTFP			
RHS-L Emergency Left Side Handle	KXTBRHSLSEMFP			
RHS-R Standard Right Side Handle	KXTBRHSRSTFP			
RHS-R Emergency Right Side Handle	KXTBRHSREMFP			
Extended handle spare parts				
RHE_B Base for Extended Handle	KXTBRHEBFP			
RHE_B Base for Extended Handle with Padlock ⁽¹⁾	KXTBRHEBFPPLK			
RHE_S 500mm Shaft	KXTARHES500			
RHE_H Standard Extended Handle	KXTARHEHST			
RHE_H Emergency Extended Handle	KXTARHEHEM			
LH Standard Large Handle, NEMA 1	KXTALHNDLST			
LH Emergency Large Handle, NEMA 1	KXTALHNDLEM			
Standard Pistol Handle with reset function, 65mm, NEMA 3R,12	OHB65J10B			
Emergency Pistol Handle with reset function, 65mm, NEMA 3R,12 ⁽¹⁾	OHY65J10B			
Standard Pistol Handle with reset function, 65mm, NEMA 4,4X ⁽¹⁾	OHB65L10B			
Emergency Pistol Handle with reset function, 65mm, NEMA 4, 4X ⁽¹⁾	OHY65L10B			
Standard Pistol Handle with reset function, 125mm, NEMA 3R,12	OHB125J10B			
Emergency Pistol Handle with reset function, 125mm, NEMA 3R,12 ⁽¹⁾	OHY125J10B			
Standard Pistol Handle with reset function, 125mm, NEMA 4,4X ⁽¹⁾	OHB125L10B			
Emergency Pistol Handle with reset function, 125mm, NEMA 4, 4X ⁽¹⁾	OHY125L10B			
148mm Pistol Handle Shaft	EXP10X148			
225mm Pistol Handle Shaft	EXP10X225			
500mm Pistol Handle Shaft	EXP10X500			

⁽¹⁾Consult ABB for availability.

IP54 protection for transmitted rotary handle⁽¹⁾

Type	Part number			
IP54 protection for transmitted handle -RHE	KXTAERHEIP54			

⁽¹⁾IEC rated only.

Flange handle⁽¹⁾

Type	Part number			
Flange Handle + Mechanism + 4ft Cable (NEMA 1, 3R, 12, 4)	KXT1N12FLHDL4			
Flange Handle + Mechanism + 6ft Cable (NEMA 1, 3R, 12, 4)	KXT1N12FLHDL6			
Flange Handle + Mechanism + 10ft Cable (NEMA 1, 3R, 12, 4)	KXT1N12FLHDL10			
Flange Handle + Mechanism + 4ft Cable (NEMA 1, 3R, 12, 4, 4X)	KXT1N4FLHDL4			
Flange Handle + Mechanism + 6ft Cable (NEMA 1, 3R, 12, 4, 4X)	KXT1N4FLHDL6			
Flange Handle + Mechanism + 10ft Cable (NEMA 1, 3R, 12, 4, 4X)	KXT1N4FLHDL10			
Flange Handle Spare Parts				
Flange Handle only (NEMA 1, 3R, 12, 4)	KXTAN12FLHDL			
Flange Handle only (NEMA 1, 3R, 12, 4, 4X)	KXTAN4XFLHDL			
Flange Handle Hardware	KXTAFLHDLHW			
Flange Mounting Hardware	KXTBFLMTHW			

⁽¹⁾Consult ABB for availability.

Ordering codes for XT1 UL/CSA Accessories

Locks



Fixed padlock

Padlock on the circuit breaker

Type	Part number
PLL removable lock with padlocks in open position	KXTBPLLREM
PLL fixed lock with padlocks in open position	KXTBPLL0P
PLL fixed lock with padlocks in open/closed position	KXTBPLL0PCL



Key lock on the circuit breaker

Key lock on the circuit breaker

Type	Part number
KLC Ronis key lock open, different keys, removable in open position	KXT1KLCCBIF
KLC Ronis key lock open, same Type A keys, removable in open position	KXT1KLCCBA
KLC Ronis key lock open, same Type B keys, removable in open position	KXT1KLCCBB
KLC Ronis key lock open, same Type C keys, removable in open position	KXT1KLCCBC
KLC Ronis key lock open, same Type D keys, removable in open position	KXT1KLCCBD
KLC Ronis key lock open/closed, different keys, removable in both positions	KXT1KLCCBOPCL



Key lock on the handle

Key lock on the rotary handle

Type	Part number
RHL Ronis key lock open, different keys, RHx	KXTARHLDIF
RHL Ronis key lock open, same Type A keys, RHx	KXTARHLA
RHL Ronis key lock open, same Type B keys, RHx	KXTARHLB
RHL Ronis key lock open, same Type C keys, RHx	KXTARHLC
RHL Ronis key lock open, same Type D keys, RHx	KXTARHLD
RHL Ronis key lock open/closed, different keys, RHx	KXTARHLOPCL



Key lock on the motor

Key lock on the motor⁽¹⁾

Type	Part number
MOL-D Ronis key lock open, different keys	KXTBEMOLDIF
MOL-S Ronis key lock open, same Type A keys	KXTBEMOLA
MOL-S Ronis key lock open, same Type B keys	KXTBEMOLB
MOL-S Ronis key lock open, same Type C keys	KXTBEMOLC
MOL-S Ronis key lock open, same Type D keys	KXTBEMOLD

⁽¹⁾IEC rated only.



Interlock

Mechanical interlock

Type	Part number
Chassis MIR-H	KXTAMIRHR
Chassis MIR-V	KXTAMIRVR
Plate XT1 F	KXT1MIRPLF
Plate XT1 P	KXT1MIRPLP
Plate XT2 F	KXT2MIRPLF
Plate XT2 P/W	KXT2MIRPLPW
Plate XT3 F	KXT3MIRPLF
Plate XT3 P	KXT3MIRPLP
Plate XT4 F	KXT4MIRPLF
Plate XT4 P/W	KXT4MIRPLPW

Sealable lock of thermal setting⁽¹⁾

Type	Part number
Lock on thermal setting for TMA trip unit	KXTAAASEALREL

⁽¹⁾IEC rated only.

Residual current devices



RC Inst / RC Sel

Residual current devices⁽¹⁾

Type	3p Part number	4p Part number		
RC Sel Low 200mm	-	KXT1ERCSEL200-4		
RC Inst	KXT1ERCINST-3	KXT1ERCINST-4		
RC Sel	KXT1ERCSEL-3	KXT1ERCSEL-4		

⁽¹⁾IEC rated only.

Panel type residual current relay⁽¹⁾

Type	Part number			
RCQ020/A 115-230V AC	KXTAERCQ230			
RCQ020/A 415V AC	KXTAERCQ415			
Toroid closed Ø 60mm	KXTTETOR60			
Toroid closed Ø 110mm	KXTTETOR110			
Toroid closed Ø 185mm	KXTTETOR185			

⁽¹⁾IEC rated only.

Installation



DIN guide

Bracket for mounting onto DIN rail⁽¹⁾

Type	3p Part number	4p Part number		
KIT DIN50022	KXT1EDIN-3	KXT1EDIN-4		
KIT DIN50022 XT1 + RC Low 200mm	-	KXT1EDINRCSELPL		
KIT DIN50022 XT1 + RC Sel/RC Inst	KXT1EDINRCPL	KXT1EDINRCPL		

⁽¹⁾IEC rated only.

Terminals, terminal covers and phase barriers



Terminal covers

Insulating terminal covers

Type	3p Part number	4p Part number		
LTC low terminal covers	KXT1LTC-3	KXT1LTC-4		
HTC high terminal covers	KXT1HTC-3	KXT1HTC-4		



Sealable screw

Sealable screws for terminal covers⁽¹⁾

Type	Part number			
Kit with two sealable screws	KXTAESSEAL			

⁽¹⁾IEC rated only.



Phase barriers

Phase barriers

Type	4pcs Part number	6pcs Part number		
PB height 25mm/0.98in	KXTBPP25-3	KXTBPP25-4		
PB height 100mm/3.94in	KXTBPP100-3	KXTBPP100-4		
PB height 200mm/7.87in	KXTBPP200-3	KXTBPP200-4		

Ordering codes for XT1 UL/CSA Accessories



EF terminal



FCCu terminal

Terminals

Type	3 pcs Part number	4 pcs Part number	6 pcs Part number	8 pcs Part number
F Front terminals	KXT1F-3PC	KXT1F-4PC	KXT1F-6PC	KXT1F-8PC
F Front terminals for MCP	KXT1F3PCMCP	-	KXT1F6PCMCP	-
EF Extended front terminals	KXT1EF-3PC	KXT1EF-4PC	KXT1EF-6PC	KXT1EF-8PC
ES Extended spread terminals	KXT1ES-3PC	KXT1ES-4PC	KXT1ES-6PC	KXT1ES-8PC
FC Cu Terminals for Cu cables 125A, 14-1/0 AWG, 1x2.5...50mm ²	KXT1CU-3PC	KXT1CU-4PC	KXT1CU-6PC	KXT1CU-8PC
FC Cu Terminals for Cu cables MCP, 14-1/0 AWG, 1x1.5...50mm ²	KXT1CUMCP-3PC	KXT1CUMCP-4PC	KXT1CUMCP-6PC	KXT1CUMCP-8PC
MC Multi cable terminals for Cu cables, 6x14-2 AWG, 6x2.5...35mm ²	KXT1MC-3PC	KXT1MC-4PC	KXT1MC-6PC	KXT1MC-8PC
R Rear adjustable terminals ⁽¹⁾	KXT1ER-3PC	KXT1ER-4PC	KXT1ER-6PC	KXT1ER-8PC
R -RC Rear terminals for residual current ⁽¹⁾	-	KXT1ERRC-4PC	-	-
FB Flexibar Terminals ⁽¹⁾	KXT1EFB-3PC	KXT1EFB-4PC	KXT1EFB-6PC	KXT1EFB-8PC

⁽¹⁾IEC rated only.

Automatic transfer devices

ATS021 - ATS022 Automatic transfer devices⁽¹⁾

Type	Part number			
ATS021	ATS021			
ATS022	ATS022			

⁽¹⁾IEC rated only.



ATS021

Spare parts

Spare parts

Type	Part number			
SA RC Sel / RC Inst - Opening solenoid for the residual current device ⁽¹⁾	KXT1ESARCFP			
AUX-C - Loose cabled auxiliary contact 250V AC ⁽²⁾	KXTAAUXCFP			
AUX-C - Loose cabled auxiliary contact 24V DC ⁽²⁾	KXTAAUXCDFP			
AUX-C - Loose cabled auxiliary contact 250V AC 600V ⁽²⁾	KXTAAUXCFPHD			
AUX-C - Loose cabled auxiliary contact 24V DC 600V ⁽²⁾	KXTAAUXCDFPHD			

⁽¹⁾IEC rated only.

⁽²⁾Un-numbered cables.



Flange

Flanges for the compartment door⁽¹⁾

Type	3p Part number	4p Part number		
Small "optional" flange for circuit breaker	KXTAEFLASMFP	KXTAEFLASMFP		
Large "standard" flange for circuit breaker	KXT1EFLAFP-3	KXT1EFLAFP-4		
Flange for MOD	KXTBEFLAMOD	KXTBEFLAMOD		
Flange for direct handle RHD	KXTAEFLARHDFP	KXTAEFLARHDFP		
Flange for residual current RC Sel/RC Sel	KXT1EFLARCFP-3	KXT1EFLARCFP-4		

⁽¹⁾IEC rated only.

Ordering codes for XT2 UL/CSA Circuit breakers

XT2 125A TMF/TMA - Fixed (F) - 3 poles - Front terminals (F) - UL/CSA

Thermomagnetic trip unit			Int Rtnng (480 V)	N		S		H		L		V		X	
Type	In	I ₃		25 kA Part number	35 kA Part number	65 kA Part number	100 kA Part number	150 kA Part number	200 kA Part number						
TMF	15	400	XT2NU3015AFF000XXX	XT2SU3015AFF000XXX	XT2HU3015AFF000XXX	XT2LU3015AFF000XXX	XT2VU3015AFF000XXX	XT2XU3015AFF000XXX							
	20	400	XT2NU3020AFF000XXX	XT2SU3020AFF000XXX	XT2HU3020AFF000XXX	XT2LU3020AFF000XXX	XT2VU3020AFF000XXX	XT2XU3020AFF000XXX							
	25	400	XT2NU3025AFF000XXX	XT2SU3025AFF000XXX	XT2HU3025AFF000XXX	XT2LU3025AFF000XXX	XT2VU3025AFF000XXX	XT2XU3025AFF000XXX							
	30	400	XT2NU3030AFF000XXX	XT2SU3030AFF000XXX	XT2HU3030AFF000XXX	XT2LU3030AFF000XXX	XT2VU3030AFF000XXX	XT2XU3030AFF000XXX							
	35	400	XT2NU3035AFF000XXX	XT2SU3035AFF000XXX	XT2HU3035AFF000XXX	XT2LU3035AFF000XXX	XT2VU3035AFF000XXX	XT2XU3035AFF000XXX							
	40	400	XT2NU3040AFF000XXX	XT2SU3040AFF000XXX	XT2HU3040AFF000XXX	XT2LU3040AFF000XXX	XT2VU3040AFF000XXX	XT2XU3040AFF000XXX							
	50	500	XT2NU3050AFF000XXX	XT2SU3050AFF000XXX	XT2HU3050AFF000XXX	XT2LU3050AFF000XXX	XT2VU3050AFF000XXX	XT2XU3050AFF000XXX							
	60	600	XT2NU3060AFF000XXX	XT2SU3060AFF000XXX	XT2HU3060AFF000XXX	XT2LU3060AFF000XXX	XT2VU3060AFF000XXX	XT2XU3060AFF000XXX							
TMA	70	700	XT2NU3070AFF000XXX	XT2SU3070AFF000XXX	XT2HU3070AFF000XXX	XT2LU3070AFF000XXX	XT2VU3070AFF000XXX	XT2XU3070AFF000XXX							
	56...80	400...800	XT2NU3080BFF000XXX	XT2SU3080BFF000XXX	XT2HU3080BFF000XXX	XT2LU3080BFF000XXX	XT2VU3080BFF000XXX	XT2XU3080BFF000XXX							
	63...90	450...900	XT2NU3090BFF000XXX	XT2SU3090BFF000XXX	XT2HU3090BFF000XXX	XT2LU3090BFF000XXX	XT2VU3090BFF000XXX	XT2XU3090BFF000XXX							
	70...100	500...1000	XT2NU3100BFF000XXX	XT2SU3100BFF000XXX	XT2HU3100BFF000XXX	XT2LU3100BFF000XXX	XT2VU3100BFF000XXX	XT2XU3100BFF000XXX							
	77...110	550...1100	XT2NU3110BFF000XXX	XT2SU3110BFF000XXX	XT2HU3110BFF000XXX	XT2LU3110BFF000XXX	XT2VU3110BFF000XXX	XT2XU3110BFF000XXX							
87.5...125	625...1250	XT2NU3125BFF000XXX	XT2SU3125BFF000XXX	XT2HU3125BFF000XXX	XT2LU3125BFF000XXX	XT2VU3125BFF000XXX	XT2XU3125BFF000XXX								

XT2 125A TMF/TMA - Fixed (F) - 4 poles - Front terminals (F) - UL/CSA

Thermomagnetic trip unit			Int Rtnng (480 V)	N		S		H		L		V		X	
Type	In	I ₃		25 kA Part number	35 kA Part number	65 kA Part number	100 kA Part number	150 kA Part number	200 kA Part number						
TMF	15	400	XT2NU4015AFF000XXX	XT2SU4015AFF000XXX	XT2HU4015AFF000XXX	XT2LU4015AFF000XXX	XT2VU4015AFF000XXX	XT2XU4015AFF000XXX							
	20	400	XT2NU4020AFF000XXX	XT2SU4020AFF000XXX	XT2HU4020AFF000XXX	XT2LU4020AFF000XXX	XT2VU4020AFF000XXX	XT2XU4020AFF000XXX							
	25	400	XT2NU4025AFF000XXX	XT2SU4025AFF000XXX	XT2HU4025AFF000XXX	XT2LU4025AFF000XXX	XT2VU4025AFF000XXX	XT2XU4025AFF000XXX							
	30	400	XT2NU4030AFF000XXX	XT2SU4030AFF000XXX	XT2HU4030AFF000XXX	XT2LU4030AFF000XXX	XT2VU4030AFF000XXX	XT2XU4030AFF000XXX							
	35	400	XT2NU4035AFF000XXX	XT2SU4035AFF000XXX	XT2HU4035AFF000XXX	XT2LU4035AFF000XXX	XT2VU4035AFF000XXX	XT2XU4035AFF000XXX							
	40	400	XT2NU4040AFF000XXX	XT2SU4040AFF000XXX	XT2HU4040AFF000XXX	XT2LU4040AFF000XXX	XT2VU4040AFF000XXX	XT2XU4040AFF000XXX							
	50	500	XT2NU4050AFF000XXX	XT2SU4050AFF000XXX	XT2HU4050AFF000XXX	XT2LU4050AFF000XXX	XT2VU4050AFF000XXX	XT2XU4050AFF000XXX							
	60	600	XT2NU4060AFF000XXX	XT2SU4060AFF000XXX	XT2HU4060AFF000XXX	XT2LU4060AFF000XXX	XT2VU4060AFF000XXX	XT2XU4060AFF000XXX							
TMA	70	700	XT2NU4070AFF000XXX	XT2SU4070AFF000XXX	XT2HU4070AFF000XXX	XT2LU4070AFF000XXX	XT2VU4070AFF000XXX	XT2XU4070AFF000XXX							
	56...80	400...800	XT2NU4080BFF000XXX	XT2SU4080BFF000XXX	XT2HU4080BFF000XXX	XT2LU4080BFF000XXX	XT2VU4080BFF000XXX	XT2XU4080BFF000XXX							
	63...90	450...900	XT2NU4090BFF000XXX	XT2SU4090BFF000XXX	XT2HU4090BFF000XXX	XT2LU4090BFF000XXX	XT2VU4090BFF000XXX	XT2XU4090BFF000XXX							
	70...100	500...1000	XT2NU4100BFF000XXX	XT2SU4100BFF000XXX	XT2HU4100BFF000XXX	XT2LU4100BFF000XXX	XT2VU4100BFF000XXX	XT2XU4100BFF000XXX							
	77...110	550...1100	XT2NU4110BFF000XXX	XT2SU4110BFF000XXX	XT2HU4110BFF000XXX	XT2LU4110BFF000XXX	XT2VU4110BFF000XXX	XT2XU4110BFF000XXX							
87.5...125	625...1250	XT2NU4125BFF000XXX	XT2SU4125BFF000XXX	XT2HU4125BFF000XXX	XT2LU4125BFF000XXX	XT2VU4125BFF000XXX	XT2XU4125BFF000XXX								

XT2 125A MCP (MA) - Fixed (F) - 3 poles - Front terminals (F) - UL/CSA

Magnetic trip unit			Int Rtnng (480 V)	H		L		V		X	
Type	In	I ₃		65 kA Part number	100 kA Part number	150 kA Part number	200 kA Part number				
MCP	3	12...33	XT2HU3003MFF000XXX								
	7	28...77	XT2HU3007MFF000XXX								
	15	45...165	XT2HU3015MFF000XXX								
	30	90...330	XT2HU3030MFF000XXX								
	50	150...550	XT2HU3050MFF000XXX								
	70	210...770	XT2HU3070MFF000XXX								
	80	240...880	XT2HU3080MFF000XXX								
	100	300...1100	XT2HU3100MFF000XXX								
125	375...1375	XT2HU3125MFF000XXX									

Ordering codes for XT2 UL/CSA Circuit breakers

XT2 125A Ekip - Fixed (F) - 3 poles - Front terminals (F) - UL/CSA

Ekip electronic trip units		Int Rtnng (480 V)						
Type	In	N 25 kA Part number	S 35 kA Part number	H 65 kA Part number	L 100 kA Part number	V 150 kA Part number	X ⁽¹⁾ 200 kA Part number	
Ekip LS/I	10	XT2NU3010EFF000XXX	XT2SU3010EFF000XXX	XT2HU3010EFF000XXX	XT2LU3010EFF000XXX	XT2VU3010EFF000XXX	XT2XU3010EFF000XXX	
	25	XT2NU3025EFF000XXX	XT2SU3025EFF000XXX	XT2HU3025EFF000XXX	XT2LU3025EFF000XXX	XT2VU3025EFF000XXX	XT2XU3025EFF000XXX	
	60	XT2NU3060EFF000XXX	XT2SU3060EFF000XXX	XT2HU3060EFF000XXX	XT2LU3060EFF000XXX	XT2VU3060EFF000XXX	XT2XU3060EFF000XXX	
	100	XT2NU3100EFF000XXX	XT2SU3100EFF000XXX	XT2HU3100EFF000XXX	XT2LU3100EFF000XXX	XT2VU3100EFF000XXX	XT2XU3100EFF000XXX	
	125	XT2NU3125EFF000XXX	XT2SU3125EFF000XXX	XT2HU3125EFF000XXX	XT2LU3125EFF000XXX	XT2VU3125EFF000XXX	XT2XU3125EFF000XXX	
Ekip LSI	10	XT2NU3010FFF000XXX	XT2SU3010FFF000XXX	XT2HU3010FFF000XXX	XT2LU3010FFF000XXX	XT2VU3010FFF000XXX	XT2XU3010FFF000XXX	
	25	XT2NU3025FFF000XXX	XT2SU3025FFF000XXX	XT2HU3025FFF000XXX	XT2LU3025FFF000XXX	XT2VU3025FFF000XXX	XT2XU3025FFF000XXX	
	60	XT2NU3060FFF000XXX	XT2SU3060FFF000XXX	XT2HU3060FFF000XXX	XT2LU3060FFF000XXX	XT2VU3060FFF000XXX	XT2XU3060FFF000XXX	
	100	XT2NU3100FFF000XXX	XT2SU3100FFF000XXX	XT2HU3100FFF000XXX	XT2LU3100FFF000XXX	XT2VU3100FFF000XXX	XT2XU3100FFF000XXX	
	125	XT2NU3125FFF000XXX	XT2SU3125FFF000XXX	XT2HU3125FFF000XXX	XT2LU3125FFF000XXX	XT2VU3125FFF000XXX	XT2XU3125FFF000XXX	
Ekip LSIG	10	XT2NU3010GFF000XXX	XT2SU3010GFF000XXX	XT2HU3010GFF000XXX	XT2LU3010GFF000XXX	XT2VU3010GFF000XXX	XT2XU3010GFF000XXX	
	25	XT2NU3025GFF000XXX	XT2SU3025GFF000XXX	XT2HU3025GFF000XXX	XT2LU3025GFF000XXX	XT2VU3025GFF000XXX	XT2XU3025GFF000XXX	
	60	XT2NU3060GFF000XXX	XT2SU3060GFF000XXX	XT2HU3060GFF000XXX	XT2LU3060GFF000XXX	XT2VU3060GFF000XXX	XT2XU3060GFF000XXX	
	100	XT2NU3100GFF000XXX	XT2SU3100GFF000XXX	XT2HU3100GFF000XXX	XT2LU3100GFF000XXX	XT2VU3100GFF000XXX	XT2XU3100GFF000XXX	
	125	XT2NU3125GFF000XXX	XT2SU3125GFF000XXX	XT2HU3125GFF000XXX	XT2LU3125GFF000XXX	XT2VU3125GFF000XXX	XT2XU3125GFF000XXX	
Ekip I	10	XT2NU3010JFF000XXX	XT2SU3010JFF000XXX	XT2HU3010JFF000XXX	XT2LU3010JFF000XXX	XT2VU3010JFF000XXX	XT2XU3010JFF000XXX	
	25	XT2NU3025JFF000XXX	XT2SU3025JFF000XXX	XT2HU3025JFF000XXX	XT2LU3025JFF000XXX	XT2VU3025JFF000XXX	XT2XU3025JFF000XXX	
	60	XT2NU3060JFF000XXX	XT2SU3060JFF000XXX	XT2HU3060JFF000XXX	XT2LU3060JFF000XXX	XT2VU3060JFF000XXX	XT2XU3060JFF000XXX	
	100	XT2NU3100JFF000XXX	XT2SU3100JFF000XXX	XT2HU3100JFF000XXX	XT2LU3100JFF000XXX	XT2VU3100JFF000XXX	XT2XU3100JFF000XXX	
	125	XT2NU3125JFF000XXX	XT2SU3125JFF000XXX	XT2HU3125JFF000XXX	XT2LU3125JFF000XXX	XT2VU3125JFF000XXX	XT2XU3125JFF000XXX	
M-LIU	25	-	-	XT2HU3025LFF000XXX	-	-	-	
	60	-	-	XT2HU3060LFF000XXX	-	-	-	
	100	-	-	XT2HU3100LFF000XXX	-	-	-	

⁽¹⁾Consult ABB for availability.

XT2 125A Ekip - Fixed (F) - 4 poles - Front terminals (F) - UL/CSA

Ekip electronic trip units		Int Rtnng (480 V)						
Type	In	N 25 kA Part number	S 35 kA Part number	H 65 kA Part number	L 100 kA Part number	V 150 kA Part number	X ⁽¹⁾ 200 kA Part number	
Ekip LS/I	10	XT2NU4010EFF000XXX	XT2SU4010EFF000XXX	XT2HU4010EFF000XXX	XT2LU4010EFF000XXX	XT2VU4010EFF000XXX	XT2XU4010EFF000XXX	
	25	XT2NU4025EFF000XXX	XT2SU4025EFF000XXX	XT2HU4025EFF000XXX	XT2LU4025EFF000XXX	XT2VU4025EFF000XXX	XT2XU4025EFF000XXX	
	60	XT2NU4060EFF000XXX	XT2SU4060EFF000XXX	XT2HU4060EFF000XXX	XT2LU4060EFF000XXX	XT2VU4060EFF000XXX	XT2XU4060EFF000XXX	
	100	XT2NU4100EFF000XXX	XT2SU4100EFF000XXX	XT2HU4100EFF000XXX	XT2LU4100EFF000XXX	XT2VU4100EFF000XXX	XT2XU4100EFF000XXX	
	125	XT2NU4125EFF000XXX	XT2SU4125EFF000XXX	XT2HU4125EFF000XXX	XT2LU4125EFF000XXX	XT2VU4125EFF000XXX	XT2XU4125EFF000XXX	
Ekip LSI	10	XT2NU4010FFF000XXX	XT2SU4010FFF000XXX	XT2HU4010FFF000XXX	XT2LU4010FFF000XXX	XT2VU4010FFF000XXX	XT2XU4010FFF000XXX	
	25	XT2NU4025FFF000XXX	XT2SU4025FFF000XXX	XT2HU4025FFF000XXX	XT2LU4025FFF000XXX	XT2VU4025FFF000XXX	XT2XU4025FFF000XXX	
	60	XT2NU4060FFF000XXX	XT2SU4060FFF000XXX	XT2HU4060FFF000XXX	XT2LU4060FFF000XXX	XT2VU4060FFF000XXX	XT2XU4060FFF000XXX	
	100	XT2NU4100FFF000XXX	XT2SU4100FFF000XXX	XT2HU4100FFF000XXX	XT2LU4100FFF000XXX	XT2VU4100FFF000XXX	XT2XU4100FFF000XXX	
	125	XT2NU4125FFF000XXX	XT2SU4125FFF000XXX	XT2HU4125FFF000XXX	XT2LU4125FFF000XXX	XT2VU4125FFF000XXX	XT2XU4125FFF000XXX	
Ekip LSIG	10	XT2NU4010GFF000XXX	XT2SU4010GFF000XXX	XT2HU4010GFF000XXX	XT2LU4010GFF000XXX	XT2VU4010GFF000XXX	XT2XU4010GFF000XXX	
	25	XT2NU4025GFF000XXX	XT2SU4025GFF000XXX	XT2HU4025GFF000XXX	XT2LU4025GFF000XXX	XT2VU4025GFF000XXX	XT2XU4025GFF000XXX	
	60	XT2NU4060GFF000XXX	XT2SU4060GFF000XXX	XT2HU4060GFF000XXX	XT2LU4060GFF000XXX	XT2VU4060GFF000XXX	XT2XU4060GFF000XXX	
	100	XT2NU4100GFF000XXX	XT2SU4100GFF000XXX	XT2HU4100GFF000XXX	XT2LU4100GFF000XXX	XT2VU4100GFF000XXX	XT2XU4100GFF000XXX	
	125	XT2NU4125GFF000XXX	XT2SU4125GFF000XXX	XT2HU4125GFF000XXX	XT2LU4125GFF000XXX	XT2VU4125GFF000XXX	XT2XU4125GFF000XXX	
Ekip I	10	XT2NU4010JFF000XXX	XT2SU4010JFF000XXX	XT2HU4010JFF000XXX	XT2LU4010JFF000XXX	XT2VU4010JFF000XXX	XT2XU4010JFF000XXX	
	25	XT2NU4025JFF000XXX	XT2SU4025JFF000XXX	XT2HU4025JFF000XXX	XT2LU4025JFF000XXX	XT2VU4025JFF000XXX	XT2XU4025JFF000XXX	
	60	XT2NU4060JFF000XXX	XT2SU4060JFF000XXX	XT2HU4060JFF000XXX	XT2LU4060JFF000XXX	XT2VU4060JFF000XXX	XT2XU4060JFF000XXX	
	100	XT2NU4100JFF000XXX	XT2SU4100JFF000XXX	XT2HU4100JFF000XXX	XT2LU4100JFF000XXX	XT2VU4100JFF000XXX	XT2XU4100JFF000XXX	
	125	XT2NU4125JFF000XXX	XT2SU4125JFF000XXX	XT2HU4125JFF000XXX	XT2LU4125JFF000XXX	XT2VU4125JFF000XXX	XT2XU4125JFF000XXX	

⁽¹⁾Consult ABB for availability.

XT2 125A switch - Fixed (F) - 3 poles - Front terminals (F) - UL/CSA

No Trip Unit			Int Rtnng (480 V)	N	H	L	V
Type	In	Mag. Override		25 kA Part number	65 kA Part number	100 kA Part number	150 kA Part number
XT2-D	125	1250		XT2NU3125DFF000XXX	XT2HU3125DFF000XXX	XT2LU3125DFF000XXX	XT2VU3125DFF000XXX

XT2 125A switch - Fixed (F) - 4 poles - Front terminals (F) - UL/CSA

No Trip Unit			Int Rtnng (480 V)	N	H	L	V
Type	In	Mag. Override		25 kA Part number	65 kA Part number	100 kA Part number	150 kA Part number
XT2-D	125	1250		XT2NU4125DFF000XXX	XT2HU4125DFF000XXX	XT2LU4125DFF000XXX	XT2VU4125DFF000XXX

XT2 125A Breaking part - UL/CSA

Type	N	S	H	L	V
	25 kA Part number	35 kA Part number	65 kA Part number	100 kA Part number	150 kA Part number
XT2 125A Breaking Part - 3p	KXT2BP3N125	KXT2BP3S125	KXT2BP3H125	KXT2BP3L125	KXT2BP3V125
XT2 125A Breaking Part - 4p	KXT2BP4N125	KXT2BP4S125	KXT2BP4H125	KXT2BP4L125	KXT2BP4V125

XT2 125A Loose trip unit - UL/CSA

Thermomagnetic trip units					
Type	In	I ₃	3p Part number	4p Part number	
TMF	50	500	KXT2TU3TMF50	KXT2TU4TMF50	
	60	600	KXT2TU3TMF60	KXT2TU4TMF60	
	70	700	KXT2TU3TMF70	KXT2TU4TMF70	
TMA	56...80	400...800	KXT2TU3TMA80	KXT2TU4TMA80	
	63...90	450...900	KXT2TU3TMA90	KXT2TU4TMA90	
	70...100	500...1000	KXT2TU3TMA100	KXT2TU4TMA100	
	77...110	550...1100	KXT2TU3TMA110	KXT2TU4TMA110	
	87.5...125	625...1250	KXT2TU3TMA125	KXT2TU4TMA125	

XT2 125A Loose trip unit - UL/CSA

Ekip electronic trip units					
Type	In	3p Part number	4p Part number		
Ekip LS/I	60	KXT2TU3LS/I60	KXT2TU4LS/I60		
	100	KXT2TU3LS/I100	KXT2TU4LS/I100		
	125	KXT2TU3LS/I125	KXT2TU4LS/I125		
Ekip LSI	60	KXT2TU3LSI60	KXT2TU4LSI60		
	100	KXT2TU3LSI100	KXT2TU4LSI100		
T2-Ekip LSIG	125	KXT2TU3LSI125	KXT2TU4LSI125		
	60	KXT2TU3LSIG60	KXT2TU4LSIG60		
	100	KXT2TU3LSIG100	KXT2TU4LSIG100		
Ekip I	125	KXT2TU3LSIG125	KXT2TU4LSIG125		
	60	KXT2TU3I60	KXT2TU4I60		
	100	KXT2TU3I100	KXT2TU4I100		
	125	KXT2TU3I125	KXT2TU4I125		

Ordering codes for XT2 UL/CSA Accessories

Fixed parts, conversion kits and accessories for fixed parts



Fixed part of plug-in

Fixed part of plug-in (P)

Type	3p Part number	4p Part number		
Kit P FP EF	KXT2PFPEF-3	KXT2PFPEF-4		
Kit P FP HR/VR ⁽¹⁾	KXT2EPFPHR-3	KXT2EPFPHR-4		

⁽¹⁾IEC rated only. The terminals are factory-mounted in the horizontal position (HR).



Fixed part of withdrawable

Fixed part of withdrawable (W)

Type	3p Part number	4p Part number		
Kit W FP EF	KXT2WFPEF-3	KXT2WFPEF-4		
Kit W FP HR/VR ⁽¹⁾	KXT2EWFPHR-3	KXT2EWFPHR-4		

⁽¹⁾IEC rated only. The terminals are factory-mounted in the horizontal position (HR).

Fixed part terminals⁽¹⁾

Type	3p Part number	4p Part number		
EF - Front extended terminals	KXT2EEFFP-3	KXT2EEFFP-4		
R - Rear terminals HR/VR	KXT2ERFP-3	KXT2ERFP-4		
PS - Rear phase separators 90mm/3.54in	KXTAEPB90-3	KXTAEPB90-4		

⁽¹⁾IEC rated only.



Conversion kit of the circuit breaker from fixed into moving part of plug-in

Conversion kit of the circuit breaker from fixed into moving part of plug-in

Type	3p Part number	4p Part number		
P MP kit	KXT2PMP-3	KXT2PMP-4		



Conversion kit for turning a fixed circuit breaker into the moving part of a withdrawable circuit breaker

Conversion kit of the circuit breaker from fixed into moving part of withdrawable

Type	3p Part number	4p Part number		
W MP kit	KXT2WMP-3	KXT2WMP-4		

Conversion kit of the fixed part from plug-in to withdrawable

Type	Part number			
FP P>W kit	KXT2FPPtoFPW			

Conversion kit of RC Sel from fixed to plug-in⁽¹⁾

Type	4p Part number			
P MP RC Sel 4p kit	KXT2EPMPRC-4			

⁽¹⁾IEC rated only.

Conversion kit of RC Sel from plug-in to withdrawable⁽¹⁾

Type	4p Part number			
W MP RC Sel kit	KXT2WFPEF-4			

⁽¹⁾IEC rated only.

Key lock for fixed part of withdrawable⁽¹⁾

Type	Part number			
KL-D key lock FP, different keys	KXTCEKLDFPW			
KL-S key lock FP, same keys N.20005	KXTCEKLSFPW			

⁽¹⁾IEC rated only.



Key lock/padlock for fixed part



Ronis key lock/padlock for fixed part

Ronis key lock for fixed part of withdrawable⁽¹⁾

Type	Part number			
KL-D Ronis FP key lock, different keys	KXTCEKLDRonFPW			
KL-S Ronis FP key lock, same Type A keys	KXTCEKLSRonFPW			

⁽¹⁾IEC rated only.

Adapter for mounting the terminals of the fixed circuit breaker on the fixed part

Type	3p Part number	4p Part number		
ADP adapter for fixed part (2 pieces)	KXT2ADP-3	KXT2ADP-4		

Note: When using ADP with ES/MC terminals, also order "Kit F Front Terminals".

Ordering codes for XT2 UL/CSA Accessories

Service releases

Shunt opening release - SOR



SOR uncabled



SOR cabled



SOR for withdrawable

Type	Fixed/Plug-in Part number	Withdrawable Part number		
Uncabled version				
SOR 12V DC	KXTASORA	-		
SOR 24-30V AC/DC	KXTASORB	-		
SOR 48-60V AC/DC	KXTASORC	-		
SOR 110...127V AC / 110...125V DC	KXTASORD	-		
SOR 220...240V AC / 220...250V DC	KXTASORE	-		
SOR 380-440V AC	KXTASORF	-		
SOR 480-525V AC	KXTASORG	-		
Cabled version				
SOR-C 12V DC	KXTASORCFPA	KXTCSORCWA		
SOR-C 24-30V AC/DC	KXTASORCFPB	KXTCSORCWB		
SOR-C 48-60V AC/DC	KXTASORCFPC	KXTCSORCWC		
SOR-C 110...127V AC / 110...125V DC	KXTASORCFPD	KXTCSORCWD		
SOR-C 220...240V AC / 220...250V DC	KXTASORCFPE	KXTCSORCWE		
SOR-C 380-440V AC	KXTASORCFPF	KXTCSORCWF		
SOR-C 480-525V AC	KXTASORCFPG	KXTCSORCWG		

Undervoltage release - UVR



UVR uncabled



UVR cabled



UVR for withdrawable

Type	Fixed/Plug-in Part number	Withdrawable Part number		
Uncabled version				
UVR 24-30V AC/DC	KXTAUVR1	-		
UVR 48V AC/DC	KXTAUVR2	-		
UVR 60V AC/DC	KXTAUVR3	-		
UVR 110...127V AC / 110...125V DC	KXTAUVR4	-		
UVR 220...240V AC / 220...250V DC	KXTAUVR5	-		
UVR 380-440V AC	KXTAUVR6	-		
UVR 480-525V AC	KXTAUVR7	-		
Cabled version				
UVR-C 24-30V AC/DC	KXTAUVRFP1	KXTCUVRW1		
UVR-C 48V AC/DC	KXTAUVRFP2	KXTCUVRW2		
UVR-C 60V AC/DC	KXTAUVRFP3	KXTCUVRW3		
UVR-C 110...127V AC / 110...125V DC	KXTAUVRFP4	KXTCUVRW4		
UVR-C 220...240V AC / 220...250V DC	KXTAUVRFP5	KXTCUVRW5		
UVR-C 380-440V AC	KXTAUVRFP6	KXTCUVRW6		
UVR-C 480-525V AC	KXTAUVRFP7	KXTCUVRW7		

Delay device for undervoltage release - UVD⁽¹⁾



Time delay device for undervoltage release

Type	Part number			
UVD 24...30V AC/DC	KT3UVD8			
UVD 48...60V AC/DC	KT3UVD7			
UVD 110...125V AC/DC	KT3UVD4			
UVD 220...250V AC/DC	KT3UVD2			

⁽¹⁾IEC rated only.

Connectors

Fourth pole connectors for withdrawable⁽¹⁾

Type	Part number		
Connector 4th Pole SOR / PS-SOR	KXTCE3PINCONSOR		
Connector 4th Pole UVR	KXTCE3PINCONUVR		

⁽¹⁾IEC rated only.

Socket plug connector on the panel⁽¹⁾

Type	Part number		
Socket -plug connector with 3 PINS	KXTAE3PINCON		
Socket -plug connector with 6 PINS	KXTAE6PINCON		
Socket -plug connector with 9 PINS	KXTAE9PINCON		
Socket -plug connector with 15 PINS	KXTAE15PINCON		

⁽¹⁾IEC rated only.

Fixed part socket-plug connector⁽¹⁾

Type	Part number		
Socket-plug connector of moving part - 12 PINS	KXTCE12PINMPCON		
Socket-plug connector of fixed part - 12 PINS	KXTCE12PINFPCON		

⁽¹⁾IEC rated only.



Socket-plug panel connector



Fixed part socket-plug connector

Electrical signals

Auxiliary contacts - AUX

Type	Fixed/Plug-in Part number	Withdrawable Part number	
Uncabled version			
AUX 250V	KXTAAUX	-	
AUX 24V DC	KXTAAUXD	-	
AUX-S51 250V	KXTCAXS51	-	
AUX-S51 24V DC	KXTCAXDS51	-	
Cabled version			
AUX-C 3 Q 250V Left	KXTCAXC3QL	-	
AUX-C 1 Q + 1 SY 250V	KXTAAXCQSYFP	KXTCAXCQSYW	
AUX-C 2 Q + 1 SY 250V	KXTAAXC2QSYFP	-	
AUX-C 3 Q + 1 SY 250V	KXTDAXC3QSYFP	KXTCAXC3QSYW	
AUX-C 3 Q + 2 SY 250V	KXTCAXC3Q2SYFP	KXTCAXC3Q2SYW	
AUX-C 2 Q + 2 SY + 1 S51 250V	KXTCAXC2Q2SYS51FP	KXTCAXC2Q2SYS51W	
AUX-S51-C 250V	KXTCAXCS51FP	KXTCAXCS51W	
AUX-C 1 Q + 1 SY 24V DC	KXTAAXCDQSYFP	KXTCAXCDQSYW	
AUX-C 3 Q + 1 SY 24V DC	KXTDAXCD3QSYFP	KXTCAXCD3QSYW	
AUX-S51-C 24V DC	KXTCAXDS51FP	KXTCAXDS51W	
AUX-C 1 Q + 1 SY 400V AC	KXTCAXC4QSYFP	KXTCAXC4QSYW	
AUX-C 2 Q 400V AC	KXTCAXC42QFP	KXTCAXC42QW	



AUX uncabled



AUX cabled



AUX for withdrawable

Ordering codes for XT2 UL/CSA Accessories



AUP - Auxiliary position contacts

Auxiliary position contacts - AUP

Type	Part number		
Cabled version			
AUP-I – Four racked-in contacts 250V for plug-in circuit breaker	KXTAAUP250IN		
AUP-I – Four racked-in contacts 24V DC for plug-in circuit breaker	KXTAAUP24IN		
AUP-R – Two racked-out contacts 250V for withdrawable circuit breaker	KXTCAUP250W		
AUP-R – Two racked-out contacts 24V DC for withdrawable circuit breaker	KXTCAUP24W		



AUE - Early auxiliary contacts

Early auxiliary contacts - AUE

Type	Fixed/Plug-in Part number	Withdrawable Part number	
AUE – Two contacts in the rotary handle RHx (Closed)	KXTAAUECLFP	KXTCAUECLW	
AUE – Two contacts in the rotary handle RHx (Open)	KXTDAUEOPFP	KXTCAUEOPW	

7

Motor Operators



MOE - Motor operator

Stored energy motor operator - MOE

Type	Part number		
MOE 24V DC	KXTCMOE24		
MOE 48...60V DC	KXTCMOE48-60		
MOE 110...125V AC/DC	KXTCMOE110-125		
MOE 220...250V AC/DC	KXTCMOE220-250		
MOE 380...440V AC	KXTCMOE380-440		
MOE 480...525V AC	KXTCMOE480-525		

Electronic stored energy motor operator - MOE-E⁽¹⁾

Type	Part number		
MOE-E 24V DC	KXTCMOEE24		
MOE-E 48...60V DC	KXTCMOEE48-60		
MOE-E 110...125V AC/DC	KXTCMOEE110-125		
MOE-E 220...250V AC/DC	KXTCMOEE220-250		
MOE-E 380...440V AC	KXTCMOEE380-440		
MOE-E 480...525V AC	KXTCMOEE480-525		

⁽¹⁾IEC rated only.

Rotary handle operating mechanisms



Direct handle



Extended handle



IP54

Rotary handle operating mechanisms

Type	Fixed/Plug-in Part number	Withdrawable Part number		
RHD Standard Direct Handle	KXTCRHDSTFP	KXTCRHDSTW		
RHD Emergency Direct Handle	KXTCRHEMFP	KXTCRHEMW		
RHE Standard Extended Handle	KXTCRHESTFP	KXTCRHESTW		
RHE Emergency Extended Handle	KXTCRHEEMFP	KXTCRHEEMW		
RHE Standard Extended Handle with Padlock ⁽¹⁾	KXTCRHESTFPPLK	KXTCRHESTWPLK		
RHE Emergency Extended Handle with Padlock ⁽¹⁾	KXTCRHEEMFPPLK	KXTCRHEEMWPLK		
RHS-L Standard Left Side Handle	KXTCRHSLSSTFP	-		
RHS-L Emergency Left Side Handle	KXTCRHSLSMFP	-		
RHS-R Standard Right Side Handle	KXTCRHSRSSTFP	-		
RHS-R Emergency Right Side Handle	KXTCRHSREMF	-		
Extended Handle Spare Parts				
RHE_B Base for Extended Handle	KXTCRHEBFP	KXTCRHEBW		
RHE_B Base for Extended Handle with Padlock ⁽¹⁾	KXTCRHEBFPPLK	KXTCRHEBWPLK		
RHE_S 500mm Shaft	KXTARHES500	KXTARHES500		
RHE_H Standard Extended Handle	KXTARHEHST	KXTARHEHST		
RHE_H Emergency Extended Handle	KXTARHEHEM	KXTARHEHEM		
LH Standard Large Handle, NEMA 1	KXTALHNDLST	KXTALHNDLST		
LH Emergency Large Handle, NEMA 1	KXTALHNDLEM	KXTALHNDLEM		
Standard Pistol Handle with reset function, 65mm, NEMA 3R, 12	0HB65J10B	0HB65J10B		
Emergency Pistol Handle with reset function, 65mm, NEMA 3R, 12 ⁽¹⁾	0HY65J10B	0HY65J10B		
Standard Pistol Handle with reset function, 65mm, NEMA 4, 4X ⁽¹⁾	0HB65L10B	0HB65L10B		
Emergency Pistol Handle with reset function, 65mm, NEMA 4, 4X ⁽¹⁾	0HY65L10B	0HY65L10B		
Standard Pistol Handle with reset function, 125mm, NEMA 3R, 12	0HB125J10B	0HB125J10B		
Emergency Pistol Handle with reset function, 125mm, NEMA 3R, 12 ⁽¹⁾	0HY125J10B	0HY125J10B		
Standard Pistol Handle with reset function, 125mm, NEMA 4, 4X ⁽¹⁾	0HB125L10B	0HB125L10B		
Emergency Pistol Handle with reset function, 125mm, NEMA 4, 4X ⁽¹⁾	0HY125L10B	0HY125L10B		
148mm Pistol Handle Shaft	0XP10X148	0XP10X148		
225mm Pistol Handle Shaft	0XP10X225	0XP10X225		
500mm Pistol Handle Shaft	0XP10X500	0XP10X500		

⁽¹⁾Consult ABB for availability.

IP54 protection for transmitted rotary handle⁽¹⁾

Type	Part number			
IP54 Protection for RHE	KXTAERHEIP54			

⁽¹⁾IEC rated only.

Flange handle⁽¹⁾

Type	Part number			
Flange Handle + Mechanism + 4ft Cable (NEMA 1, 3R, 12, 4)	KXT2N12FLHDL4			
Flange Handle + Mechanism + 6ft Cable (NEMA 1, 3R, 12, 4)	KXT2N12FLHDL6			
Flange Handle + Mechanism + 10ft Cable (NEMA 1, 3R, 12, 4)	KXT2N12FLHDL10			
Flange Handle + Mechanism + 4ft Cable (NEMA 1, 3R, 12, 4, 4X)	KXT2N4XFLHDL4			
Flange Handle + Mechanism + 6ft Cable (NEMA 1, 3R, 12, 4, 4X)	KXT2N4XFLHDL6			
Flange Handle + Mechanism + 10ft Cable (NEMA 1, 3R, 12, 4, 4X)	KXT2N4XFLHDL10			

Flange Handle Spare Parts

Flange Handle only (NEMA 1, 3R, 12, 4)	KXTAN12FLHDL			
Flange Handle only (NEMA 1, 3R, 12, 4, 4X)	KXTAN4XFLHDL			
Flange Handle Hardware	KXTAFLHDLHW			
Flange Mounting Hardware	KXTCFLMTHW			

⁽¹⁾Consult ABB for availability.

Ordering codes for XT2 UL/CSA Accessories



Fixed padlock



Key lock on the circuit breaker



Key lock on the handle



Key lock on the motor



Front for operating lever mechanism



Interlock

Locks

Padlock on the circuit breaker

Type	Part number
PLL Fixed lock with padlocks in open position	KXTCPLOP
PLL Fixed lock with padlocks in open/closed position	KXTCPLOPCL

Key lock on the circuit breaker

Type	Part number
KLC Ronis key lock open, different keys, removable in open position	KXTCKLCCBDIF
KLC Ronis key lock open, same Type A keys, removable in open position	KXTCKLCCBA
KLC Ronis key lock open, same Type B keys, removable in open position	KXTCKLCCBB
KLC Ronis key lock open, same Type C keys, removable in open position	KXTCKLCCBC
KLC Ronis key lock open, same Type D keys, removable in open position	KXTCKLCCBD
KLC Ronis key lock open/closed, different keys, removable in both positions	KXTCKLCCBOPCL

Key lock on the rotary handle / key lock on the front for locks

Type	Part number
RHL Ronis key lock open, different keys, RHx/FLD	KXTARHLDIF
RHL Ronis key lock open, same Type A keys, RHx/FLD	KXTARHLA
RHL Ronis key lock open, same Type B keys, RHx/FLD	KXTARHLB
RHL Ronis key lock open, same Type C keys, RHx/FLD	KXTARHLC
RHL Ronis key lock open, same Type D keys, RHx/FLD	KXTARHLD
RHL Ronis key lock open/closed, different keys, RHx	KXTARHLOPCL
RHL Ronis key lock open/closed, different keys, FLD	KXTCRHLFLD

Key lock on the motor⁽¹⁾

Type	Part number
MOL-D Ronis key lock open, different keys	KXTCEMOLDIF
MOL-S Ronis key lock open, same Type A keys	KXTCEMOLA
MOL-S Ronis key lock open, same Type B keys	KXTCEMOLB
MOL-S Ronis key lock open, same Type C keys	KXTCEMOLC
MOL-S Ronis key lock open, same Type D keys	KXTCEMOLD
MOL-M Key lock against manual operation	KXTCEMOLMO

⁽¹⁾IEC rated only

Front for operating lever mechanism

Type	Fixed/Plug-in Part number	Withdrawable Part number
FLD front for operating lever mechanism	KXTCFLDFP	KXTCFLDW

Mechanical interlock

Type	Part number
Chassis MIR-H	KXTAMIRHR
Chassis MIR-V	KXTAMIRVR
Plate XT1 F	KXT1MIRPLF
Plate XT1 P	KXT1MIRPLP
Plate XT2 F	KXT2MIRPLF
Plate XT2 P/W	KXT2MIRPLPW
Plate XT4 F	KXT4MIRPLF
Plate XT4 P/W	KXT4MIRPLPW

Residual current devices



RC Sel

Residual current devices⁽¹⁾

Type	3p Part number	4p Part number
RC Sel	–	KXT2ERCSEL-4

⁽¹⁾IEC rated only.

Panel type residual current relay⁽¹⁾

Type	Part number
RCQ020/A 115-230V AC	KXTAERCQ230
RCQ020/A 415V AC	KXTAERCQ415
Toroid closed Ø 60mm	KXTTETOR60
Toroid closed Ø 110mm	KXTTETOR110
Toroid closed Ø 185mm	KXTTETOR185

⁽¹⁾IEC rated only.

Installation



DIN guide

Bracket for DIN rail mounting

Type	3p Part number	4p Part number
KIT DIN50022 ⁽¹⁾	KXTCEDINPL	KXTCEDINPL
KIT DIN50022 UL	KXT2DIN-3	KXT2DIN-4

⁽¹⁾IEC rated only.

Terminals, terminal covers and phase barriers



Terminal cover

Insulating terminal covers

Type	3p Part number	4p Part number
LTC low terminal covers	KXT2LTC-3	KXT2LTC-4
HTC high terminal covers	KXT2HTC-3	KXT2HTC-4

Sealable screws for terminal covers⁽¹⁾



Sealable screw

Type	Part number
Kit with two sealable screws	KXTAESSEAL

⁽¹⁾IEC rated only.

Phase barriers



Phase barriers

Type	4 pcs Part number	6 pcs Part number
PB Height 25mm/0.98in	KXTCPB25-3	KXTCPB25-4
PB Height 100mm/3.94in	KXTCPB100-3	KXTCPB100-4
PB Height 200mm/7.87in	KXTCPB200-3	KXTCPB200-4

Ordering codes for XT2 UL/CSA Accessories



EF terminal



FCCu terminal

Terminals

Type	3 pcs Part number	4 pcs Part number	6 pcs Part number	8 pcs Part number
F Front terminals	KXT2F-3PC	KXT2F-4PC	KXT2F-6PC	KXT2F-8PC
EF Extended front terminals	KXT2EF-3PC	KXT2EF-4PC	KXT2EF-6PC	KXT2EF-8PC
ES Extended spread terminals	KXT2ES-3PC	KXT2ES-4PC	KXT2ES-6PC	KXT2ES-8PC
FC CuAl Terminals for CuAl cables 110A, 14-1/0 AWG, 1x2.5...50mm ²⁽¹⁾	KXT2CUAL1-3PC	KXT2CUAL1-4PC	-	-
FC Cu Terminals for Cu cables 125A, 14-1/0 AWG, 1x2.5...95mm ²	KXT2CU-3PC	KXT2CU-4PC	KXT2CU-6PC	KXT2CU-8PC
MC Multi cable terminals for Cu cables, 6X14-2 AWG, 6X2.5...35mm ²	KXT2MC-3PC	KXT2MC-4PC	KXT2MC-6PC	KXT2MC-8PC
R Rear adjustable terminals ⁽²⁾	KXT2ER-3PC	KXT2ER-4PC	KXT2ER-6PC	KXT2ER-8PC
FB Flexibar terminals ⁽²⁾	KXT2EFB-3PC	KXT2EFB-4PC	KXT2EFB-6PC	KXT2EFB-8PC

⁽¹⁾Consult ABB for availability.

⁽²⁾IEC rated only.

Accessories for electronic trip units

General electronic trip unit accessories⁽¹⁾

Type	Fixed/Plug-in Part number	Withdrawable Part number		
Ekip Display	KXTCEDISP	KXTCEDISP		
Ekip LED Meter	KXTCELED	KXTCELED		
Ekip Com	KXTCECOMFP	KXTCECOMW		
HMI030 interface on front of panel	HMI030	HMI030		

⁽¹⁾IEC rated only.



Ekip Display



Ekip LED Meter

Current sensor for external neutral⁽¹⁾

Type	Part number			
CT external neutral of 10A	KXT2ECT10			
CT external neutral of 25A	KXT2ECT25			
CT external neutral of 63A	KXT2ECT63			
CT external neutral of 100A	KXT2ECT100			
CT external neutral of 160A	KXT2ECT160			

⁽¹⁾IEC rated only.

Connection kits

Type	Fixed/Plug-in Part number	Withdrawable Part number		
24V DC auxiliary voltage kit for electronic trip units ⁽¹⁾	KXTCECAUXFP	KXTCECAUXW		
External neutral connection kit	KXTCECNEFP	KXTCECNEW		

⁽¹⁾IEC rated only.



Ekip T&P unit

Test and configuration units⁽¹⁾

Type	Part number			
Ekip TT - Trip test unit	ZEAEKPTT			
Ekip T&P - Programming and test unit	EKIP			

⁽¹⁾IEC rated only.

Automatic transfer devices



ATS021

ATS021 - ATS022 automatic transfer devices⁽¹⁾

Type	Part number			
ATS021	ATS021			
ATS022	ATS022			

⁽¹⁾IEC rated only.

Spare parts

Type	Fixed/Plug-in Part number	Withdrawable Part number		
SA RC Sel / RC Inst - Opening solenoid for the residual current device ⁽¹⁾	KXT2ESARCFP	KXT2ESARCW		
AUX-C - Loose cabled auxiliary contact 250V AC ⁽²⁾	KXTAAUXCFP	KXTCEAUXCW		
AUX-C - Loose cabled auxiliary contact 24V DC ⁽²⁾	KXTAAUXCDFP	KXTCEAUXCDW		
AUX-C - Loose cabled auxiliary contact 250V AC HD for 600V	KXTAAUXCFPHD	KXTCAUXCWH		
AUX-C - Loose cabled auxiliary contact 24V DC HD for 600V	KXTAAUXCDFPHD	KXTCAUXCDWH		

⁽¹⁾IEC rated only.

⁽²⁾Un-numbered cables. Withdrawable versions are IEC rated only.



Fixed/Moving part connector for withdrawable

Connectors for fixed part/moving part of withdrawable circuit breakers⁽¹⁾

Type	Part number			
1 connector for with 2 pins for SOR/UVR up to 400V	KXTCE2PINCONSOUV			
1 connector with 3 pins for AUX up to 400V	KXTCE3PINCONAUX			

⁽¹⁾IEC rated only.



Flange

Flanges for the compartment door⁽¹⁾

Type	3p Fixed/Plug-in Part number	4p Fixed/Plug-in Part number	3p Withdrawable Part number	4p Withdrawable Part number
Small "optional" flange for circuit breaker	KXTAEFLASMFP	KXTAEFLASMFP	-	-
Large "standard" flange for circuit breaker	KXT2EFLAFP-3	KXT2EFLAFP-4	-	-
Flange for MOE/MOE-E/FLD	KXTCEFLAMOEFP	KXTCEFLAMOEFP	KXTCEFLAMOEW	KXTCEFLAMOEW
Flange for direct handle RHD	KXTAEFLARHDFP	KXTAEFLARHDFP	KXTCEFLARHDW	KXTCEFLARHDW
Flange for residual current RC Sel	-	KXT2EFLARCFP-4	-	KXT2EFLARCW-4

⁽¹⁾IEC rated only.

Ordering codes for XT3 UL/CSA Circuit breakers

XT3 225A TMF - Fixed (F) - 3 poles - Front terminals (F) - UL/CSA

Thermal magnetic trip unit			Int Rtnng (480 V)	N 25kA Part number	S 35kA Part number
Type	In	I ₃			
TMF	60	600		XT3NU3060AFF000XXX	XT3SU3060AFF000XXX
	70	700		XT3NU3070AFF000XXX	XT3SU3070AFF000XXX
	80	800		XT3NU3080AFF000XXX	XT3SU3080AFF000XXX
	90	900		XT3NU3090AFF000XXX	XT3SU3090AFF000XXX
	100	1000		XT3NU3100AFF000XXX	XT3SU3100AFF000XXX
	110	1100		XT3NU3110AFF000XXX	XT3SU3110AFF000XXX
	125	1250		XT3NU3125AFF000XXX	XT3SU3125AFF000XXX
	150	1500		XT3NU3150AFF000XXX	XT3SU3150AFF000XXX
	175	1750		XT3NU3175AFF000XXX	XT3SU3175AFF000XXX
	200	2000		XT3NU3200AFF000XXX	XT3SU3200AFF000XXX
	225	2250		XT3NU3225AFF000XXX	XT3SU3225AFF000XXX

XT3 225A TMF - Fixed (F) - 4 poles - Front terminals (F) - UL/CSA

Thermal magnetic trip unit			Int Rtnng (480 V)	N 25kA Part number	S 35kA Part number
Type	In	I ₃			
TMF	60	600		XT3NU4060AFF000XXX	XT3SU4060AFF000XXX
	70	700		XT3NU4070AFF000XXX	XT3SU4070AFF000XXX
	80	800		XT3NU4080AFF000XXX	XT3SU4080AFF000XXX
	90	900		XT3NU4090AFF000XXX	XT3SU4090AFF000XXX
	100	1000		XT3NU4100AFF000XXX	XT3SU4100AFF000XXX
	110	1100		XT3NU4110AFF000XXX	XT3SU4110AFF000XXX
	125	1250		XT3NU4125AFF000XXX	XT3SU4125AFF000XXX
	150	1500		XT3NU4150AFF000XXX	XT3SU4150AFF000XXX
	175	1750		XT3NU4175AFF000XXX	XT3SU4175AFF000XXX
	200	2000		XT3NU4200AFF000XXX	XT3SU4200AFF000XXX
	225	2250		XT3NU4225AFF000XXX	XT3SU4225AFF000XXX

XT3 225A MCP (MA) - Fixed (F) - 3 poles - Front terminals (F) - UL/CSA

Magnetic trip unit			Int Rtnng (480 V)	S 35 kA Part number
Type	In	I ₃		
MCP	100	600...1200		XT3SU3100MFF000XXX
	110	660...1320		XT3SU3110MFF000XXX
	125	750...1500		XT3SU3125MFF000XXX
	150	900...1800		XT3SU3150MFF000XXX
	200	1200...2400		XT3SU3200MFF000XXX

XT3 225A switch - Fixed (F) - 3 poles - Front terminals (F) - UL/CSA

No trip unit			Int Rtnng (480 V)	N	S		
Type	In	Mag. Override		25kA Part number	35kA Part number		
XT3 - D	225	2250		XT3NU3225DFF000XXX	XT3SU3225DFF000XXX		

XT3 225A switch - Fixed (F) - 4 poles - Front terminals (F) - UL/CSA

No trip unit			Int Rtnng (480 V)	N	S		
Type	In	Mag. Override		25kA Part number	35kA Part number		
XT3 - D	225	2250		XT3NU4225DFF000XXX	XT3SU4225DFF000XXX		

Ordering codes for XT3 UL/CSA Accessories



Fixed part of plug-in

Fixed parts, conversion kits and accessories for fixed parts

Fixed part of plug-in (P)

Type	3p Part number	4p Part number
Kit P FP EF	KXT3PFPEF-3	KXT3PFPEF-4
Kit P FP HR/VR ⁽¹⁾	KXT3EPFPHR-3	KXT3EPFPHR-4

⁽¹⁾IEC rated only. The terminals are factory-mounted in the horizontal position (HR).

Terminals for the fixed parts⁽¹⁾

Type	3p Part number	4p Part number
EF - Front extended terminals	KXT3EEFFP-3	KXT3EEFFP-4
R - Rear terminals HR/VR	KXTEERFP-3	KXTEERFP-4
PS - Rear phase separators 90mm/3.54in	KXTAEPB90-3	KXTAEPB90-4

⁽¹⁾IEC rated only.

Conversion kit of the circuit breaker from fixed into moving part of plug-in

Type	3p Part number	4p Part number
P MP kit	KXT3PMP-3	-



Conversion kit for turning a fixed circuit breaker into the moving part of a plug-in circuit breaker

Adapter for mounting the terminals of the fixed circuit breaker on the fixed part

Type	3p Part number	4p Part number
ADP adapter for fixed part (2 pieces)	KXT3EADP-3	KXT3EADP-4

Note: When using ADP with ES/MC terminals, also order "Kit F Front Terminals".



Fixed part adapter

Service releases



SOR uncabled



SOR cabled



UVR uncabled



UVR cabled



Time delay device for undervoltage release

Shunt opening release - SOR

Type	Part number			
Uncabled version				
SOR 12V DC	KXTASORA			
SOR 24-30V AC/DC	KXTASORB			
SOR 48-60V AC/DC	KXTASORC			
SOR 110...127V AC / 110...125V DC	KXTASORD			
SOR 220...240V AC / 220...250V DC	KXTASORE			
SOR 380-440V AC	KXTASORF			
SOR 480-525V AC	KXTASORG			
Cabled version				
SOR-C 12V DC	KXTASORCFPA			
SOR-C 24-30V AC/DC	KXTASORCFPB			
SOR-C 48-60V AC/DC	KXTASORCFPC			
SOR-C 110...127V AC / 110...125V DC	KXTASORCFPD			
SOR-C 220...240V AC / 220...250V DC	KXTASORCFPE			
SOR-C 380-440V AC	KXTASORCFPF			
SOR-C 480-525V AC	KXTASORCFPG			

Undervoltage release - UVR

Type	Part number			
Uncabled version				
UVR 24-30V AC/DC	KXTAUVR1			
UVR 48V AC/DC	KXTAUVR2			
UVR 60V AC/DC	KXTAUVR3			
UVR 110...127V AC / 110...125V DC	KXTAUVR4			
UVR 220...240V AC / 220...250V DC	KXTAUVR5			
UVR 380-440V AC	KXTAUVR6			
UVR 480-525V AC	KXTAUVR7			
Cabled version				
UVR-C 24-30V AC/DC	KXTAUVRCFP1			
UVR-C 48V AC/DC	KXTAUVRCFP2			
UVR-C 60V AC/DC	KXTAUVRCFP3			
UVR-C 110...127V AC / 110...125V DC	KXTAUVRCFP4			
UVR-C 220...240V AC / 220...250V DC	KXTAUVRCFP5			
UVR-C 380-440V AC	KXTAUVRCFP6			
UVR-C 480-525V AC	KXTAUVRCFP7			

Delay device for undervoltage release - UVD⁽¹⁾

Type	Part number			
UVD 24...30V AC/DC	KT3UVD8			
UVD 48...60V AC/DC	KT3UVD7			
UVD 110...125V AC/DC	KT3UVD4			
UVD 220...250V AC/DC	KT3UVD2			

⁽¹⁾IEC rated only.

Ordering codes for XT3 UL/CSA Accessories



Socket-plug panel connector

Connectors

Socket plug connector on the panel⁽¹⁾

Type	Part number		
Socket-plug connector with 3 PINS	KXTAE3PINCON		
Socket-plug connector with 6 PINS	KXTAE6PINCON		
Socket-plug connector with 9 PINS	KXTAE9PINCON		
Socket-plug connector with 15 PINS	KXTAE15PINCON		

⁽¹⁾IEC rated only.



AUX uncabled

Electrical signals

Auxiliary contacts - AUX

Type	Part number		
Uncabled version			
AUX 250V	KXTAAUX		
AUX 24V DC	KXTAAUXD		
Cabled version			
AUX-C 3 Q 250V Left	KXT3AXC3QL		
AUX-C 1 Q + 1 SY 250V	KXTAAXCQSYFP		
AUX-C 2 Q + 1 SY 250V	KXTAAXC2QSYFP		
AUX-C 3 Q + 1 SY 250V	KXTDAXC3QSYFP		
AUX-C 1 Q + 1 SY 24V DC	KXTAAXCDQSYFP		
AUX-C 3 Q + 1 SY 24V DC	KXTDAXCD3QSYFP		



AUX cabled

Auxiliary position contacts - AUP

Type	Part number		
Cabled version			
AUP-I – Four racked-in contacts 250V for plug-in circuit breaker	KXTAAUP250IN		
AUP-I – Four racked-in contacts 24V DC for plug-in circuit breaker	KXTAAUP24IN		



AUP - Auxiliary position contacts

Early auxiliary contacts - AUE

Type	Part number		
AUE – Two contacts in the rotary handle RHx (Closed)	KXTAAUECLFP		
AUE – Two contacts in the rotary handle RHx (Open)	KXTDAUEOPFP		



AUE - Early auxiliary contacts

Motor operators

Motor operator with direct action - MOD

Type	Part number		
MOD 24V DC	KXTBMOD24		
MOD 48...60V DC	KXTBMOD48-60		
MOD 110...125V AC/DC	KXTBMOD110-125		
MOD 220...250V AC/DC	KXTBMOD220-250		
MOD 380...440V AC	KXTBMOD280-240		
MOD 480...525V AC	KXTBMOD480-525		



Motor operator

Rotary handle operating mechanisms



Direct rotary handle



Extended rotary handle



IP54

Rotary handle operating mechanisms

Type	Part number		
RHD standard direct handle	KXTBRHDSTFP		
RHD emergency direct handle	KXTBRHDEMFP		
RHE standard extended handle	KXTBRHESTFP		
RHE emergency extended handle	KXTBRHEMFP		
RHE standard extended handle with padlock ⁽¹⁾	KXTBRHESTFPPLK		
RHE emergency extended handle with padlock ⁽¹⁾	KXTBRHEMFPPLK		
RHS-L standard left side handle	KXTBRHSLSTFP		
RHS-L emergency left side handle	KXTBRHSLMFP		
RHS-R standard right side handle	KXTBRHSRSTFP		
RHS-R emergency right side handle	KXTBRHSREMFP		
Extended Handle Spare Parts			
RHE_B base for extended handle	KXTBRHEBFP		
RHE_B base for extended handle with padlock ⁽¹⁾	KXTBRHEBFPPLK		
RHE_S 500mm shaft	KXTARHES500		
RHE_H standard extended handle	KXTARHEHST		
RHE_H emergency extended handle	KXTARHEHEM		
LH standard large handle, NEMA 1	KXTALHNDLST		
LH emergency large handle, NEMA 1	KXTALHNDLEM		
Standard Pistol Handle with reset function, 65mm, NEMA 3R, 12	0HB65J10B		
Emergency Pistol Handle with reset function, 65mm, NEMA 3R, 12 ⁽¹⁾	0HY65J10B		
Standard Pistol Handle with reset function, 65mm, NEMA 4, 4X ⁽¹⁾	0HB65L10B		
Emergency Pistol Handle with reset function, 65mm, NEMA 4, 4X ⁽¹⁾	0HY65L10B		
Standard Pistol Handle with reset function, 125mm, NEMA 3R, 12	0HB125J10B		
Emergency Pistol Handle with reset function, 125mm, NEMA 3R, 12 ⁽¹⁾	0HY125J10B		
Standard Pistol Handle with reset function, 125mm, NEMA 4, 4X ⁽¹⁾	0HB125L10B		
Emergency Pistol Handle with reset function, 125mm, NEMA 4, 4X ⁽¹⁾	0HY125L10B		
148mm Pistol Handle Shaft	0XP10X148		
225mm Pistol Handle Shaft	0XP10X225		
500mm Pistol Handle Shaft	0XP10X500		

⁽¹⁾Consult ABB for availability.

IP54 Protection for extended rotary handle⁽¹⁾

Type	Part number		
IP54 protection for RHE	KXTAERHEIP54		

⁽¹⁾IEC rated only.

Flange handle⁽¹⁾

Type	Part number		
Flange Handle + Mechanism + 4ft Cable (NEMA 1, 3R, 12, 4)	KXT3N12FLHDL4		
Flange Handle + Mechanism + 6ft Cable (NEMA 1, 3R, 12, 4)	KXT3N12FLHDL6		
Flange Handle + Mechanism + 10ft Cable (NEMA 1, 3R, 12, 4)	KXT3N12FLHDL10		
Flange Handle + Mechanism + 4ft Cable (NEMA 1, 3R, 12, 4, 4X)	KXT3N4XFLHDL4		
Flange Handle + Mechanism + 6ft Cable (NEMA 1, 3R, 12, 4, 4X)	KXT3N4XFLHDL6		
Flange Handle + Mechanism + 10ft Cable (NEMA 1, 3R, 12, 4, 4X)	KXT3N4XFLHDL10		

Flange Handle Spare Parts

Flange Handle only (NEMA 1, 3R, 12, 4)	KXTAN12FLHDL		
Flange Handle only (NEMA 1, 3R, 12, 4, 4X)	KXTAN4XFLHDL		
Flange Handle Hardware	KXTAFLHDLHW		
Flange Mounting Hardware	KXTBFLMTHW		

⁽¹⁾Consult ABB for availability

Ordering codes for XT3 UL/CSA Accessories

Locks



Fixed padlock

Padlock on the circuit breaker

Type	Part number
PLL removable lock with padlocks in open position	KXTBPLLREM
PLL fixed lock with padlocks in open position	KXTBPLL0P
PLL fixed lock with padlocks in open/closed position	KXTBPLL0PCL



Key lock on the circuit breaker

Key lock on the circuit breaker

Type	Part number
KLC Ronis key lock open, different keys, removable in open position	KXT3KLCCBIF
KLC Ronis key lock open, same Type A keys, removable in open position	KXT3KLCCBA
KLC Ronis key lock open, same Type B keys, removable in open position	KXT3KLCCBB
KLC Ronis key lock open, same Type C keys, removable in open position	KXT3KLCCBC
KLC Ronis key lock open, same Type D keys, removable in open position	KXT3KLCCBD
KLC Ronis key lock open/closed, different keys, removable in both positions	KXT3KLCCBOPCL

7



Key lock on the handle

Key lock on the rotary handle

Type	Part number
RHL Ronis key lock open, different keys, RHx	KXTARHLDIF
RHL Ronis key lock open, same Type A keys, RHx	KXTARHLA
RHL Ronis key lock open, same Type B keys, RHx	KXTARHLB
RHL Ronis key lock open, same Type C keys, RHx	KXTARHLC
RHL Ronis key lock open, same Type D keys, RHx	KXTARHLD
RHL Ronis key lock open/closed, different keys, RHx	KXTARHLOPCL



Key lock on the motor

Key lock on the motor⁽¹⁾

Type	Part number
MOL-D Ronis key lock open, different keys	KXTBEMOLDIF
MOL-S Ronis key lock open, same Type A keys	KXTBEMOLA
MOL-S Ronis key lock open, same Type B keys	KXTBEMOLB
MOL-S Ronis key lock open, same Type C keys	KXTBEMOLC
MOL-S Ronis key lock open, same Type D keys	KXTBEMOLD

⁽¹⁾IEC rated only.



Interlock

Mechanical interlock

Type	Part number
Chassis MIR-H	KXTAMIRHR
Chassis MIR-V	KXTAMIRVR
Plate XT1 F	KXT1MIRPLF
Plate XT1 P	KXT1MIRPLP
Plate XT3 F	KXT3MIRPLF
Plate XT3 P	KXT3MIRPLP

Sealable lock of thermal setting⁽¹⁾

Type	Part number
Lock on thermal setting for TMA or MA trip units	KXTAAASEALREL

⁽¹⁾IEC rated only.



RC Inst / RC Sel

Residual current devices

Residual current devices

Type	3p Part number	4p Part number
RC inst ⁽¹⁾	KXT3ERCINST-3	KXT3ERCINST-4
RC Sel ⁽¹⁾	KXT3ERCSEL-3	KXT3ERCSEL-4
RC B Type ⁽¹⁾	-	KXT3ERCB-4

⁽¹⁾IEC rated only.

Panel-type residual current relay⁽¹⁾

Type	Part number
RCQ020/A 115-230V AC	KXTAERCQ230
RCQ020/A 415V AC	KXTAERCQ415
Toroid closed Ø 60mm	KXTTETOR60
Toroid closed Ø 110mm	KXTTETOR110
Toroid closed Ø 185mm	KXTTETOR185

⁽¹⁾IEC rated only.

Installation

Bracket for DIN rail mounting⁽¹⁾

Type	3p Part number	4p Part number
KIT DIN50022	KXT3EDIN-3	KXT3EDIN-4
KIT DIN50022 XT3+RC Sel/RC Inst	KXT3EDINRCPL	KXT3EDINRCPL

⁽¹⁾IEC rated only.



DIN guide

Terminals, terminal covers and phase barriers

Insulating terminal covers

Type	3p Part number	4p Part number
LTC low terminal covers	KXT3LTC-3	KXT3LTC-4
HTC high terminal covers	KXT3HTC-3	KXT3HTC-4



Terminal covers

Sealable screws for terminal covers⁽¹⁾

Type	Part number
Kit with two sealable screws	KXTAESSEAL

⁽¹⁾IEC rated only.



Sealable screw

Phase barriers

Type	4pcs Part number	6pcs Part number
PB height 25mm/0.98in	KXTBPPB25-3	KXTBPPB25-4
PB height 100mm/3.94in	KXTBPPB100-3	KXTBPPB100-4
PB height 200mm/7.87in	KXTBPPB200-3	KXTBPPB200-4



Phase barriers

Ordering codes for XT3 UL/CSA Accessories



EF terminal



FCCuAl terminal

Terminals

Type	3 pcs Part number	4 pcs Part number	6 pcs Part number	8 pcs Part number
F Front terminals	KXT3F-3PC	KXT3F-4PC	KXT3F-6PC	KXT3F-8PC
EF Extended front terminals	KXT3EF-3PC	KXT3EF-4PC	KXT3EF-6PC	KXT3EF-8PC
ES Extended spread terminals	KXT3ES-3PC	KXT3ES-4PC	KXT3ES-6PC	KXT3ES-8PC
FC CuAl Terminals for CuAl cables 100A, 14-1/0 AWG, 1x2.5...50mm ⁽¹⁾	KXT3CUAL1-3PC	KXT3CUAL1-4PC	KXT3CUAL1-6PC	KXT3CUAL1-8PC
FC CuAl Terminals for CuAl cables w/Control Tap 100A, 14-1/0 AWG, 1x2.5...50mm ⁽¹⁾	KXT3CUAL1C-3PC	KXT3CUAL1C-4PC	-	-
FC CuAl Terminals for CuAl cables 225A, 4 AWG -300 kcmil, 1x35...150mm ⁽¹⁾	KXT3CUAL2-3PC	KXT3CUAL2-4PC	KXT3CUAL2-6PC	KXT3CUAL2-8PC
FC CuAl Terminals for CuAl cables w/Control Tap 225A, 4 AWG-300 kcmil, 1x35...150mm ⁽¹⁾	KXT3CUAL2C-3PC	KXT3CUAL2C-4PC	-	-
FC Cu Terminals for Cu cables, 10-250 AWG, 1x6...185mm ²	KXT3CU-3PC	KXT3CU-4PC	KXT3CU-6PC	KXT3CU-8PC
MC Multi cable terminals for Cu cables, 6x12-2 AWG, 6x2.5...35mm ²	KXT3MC-3PC	KXT3MC-4PC	KXT3MC-6PC	KXT3MC-8PC
R Rear adjustable terminals ⁽²⁾	KXT3ER-3PC	KXT3ER-4PC	KXT3ER-6PC	KXT3ER-8PC
R-RC Rear terminal for residual current ⁽²⁾	-	KXT3ERRC-4PC	-	-
FB Flexibar terminals ⁽²⁾	KXT3EFB-3PC	KXT3EFB-4PC	KXT3EFB-6PC	KXT3EFB-8PC

⁽¹⁾Consult ABB for availability.

⁽²⁾IEC rated only.

Automatic transfer devices

ATS021 - ATS022 automatic transfer devices⁽¹⁾

Type	Part number			
ATS021	ATS021			
ATS022	ATS022			

⁽¹⁾IEC rated only.



ATS021

Spare parts

Type	Fixed/Plugin-in Part number			
SA RC Sel/RC B Type - opening solenoid for the residual current device ⁽¹⁾	KXT3ESARCFP			
SA RC B Type - Opening solenoid for the residual current device ⁽¹⁾	KXT3ESARCFPB			
AUX-C - Loose cabled auxiliary contact 250V AC ⁽²⁾	KXTAAUXCFP			
AUX-C - Loose cabled auxiliary contact 24V DC ⁽²⁾	KXTAAUXCDFP			
AUX-C - Loose cabled auxiliary contact 250V AC HD for 600V	KXTAAUXCFPHD			
AUX-C - Loose cabled auxiliary contact 24V DC HD for 600V	KXTAAUXCDFPHD			

⁽¹⁾IEC rated only

⁽²⁾Un-numbered cables

Flanges for the compartment door

Type	3p Part number	4p Part number		
Small "optional" flange for circuit breaker	KXTAEFLASMFP	KXTAEFLASMFP		
Large "standard" flange for circuit breaker	KXT3EFLAFP-3	KXT3EFLAFP-4		
Flange for MOD	KXTBEFLAMOD	KXTBEFLAMOD		
Flange for direct handle RHD	KXTAEFLARHDFP	KXTAEFLARHDFP		
Flange for residual current RC Sel / Inst	KXT3EFLARCFP-3	KXT3EFLARCFP-4		

⁽¹⁾IEC rated only.



Flange

Ordering codes for XT4 UL/CSA Circuit breakers

XT4 250A TMF - Fixed (F) - 2 poles - Front terminals (F) - UL/CSA

Thermal magnetic trip unit			Int Rtnng (480 V)	N 25kA Part number
Type	In	I _s		
TMF	25	400		XT4NU2025AFF000XXX
	30	400		XT4NU2030AFF000XXX
	35	400		XT4NU2035AFF000XXX
	40	400		XT4NU2040AFF000XXX
	50	500		XT4NU2050AFF000XXX
	60	600		XT4NU2060AFF000XXX
	70	700		XT4NU2070AFF000XXX
	80	800		XT4NU2080AFF000XXX
	90	900		XT4NU2090AFF000XXX
	100	1000		XT4NU2100AFF000XXX
	110	1100		XT4NU2110AFF000XXX
	125	1250		XT4NU2125AFF000XXX
	150	1500		XT4NU2150AFF000XXX
	175	1750		XT4NU2175AFF000XXX
	200	2000		XT4NU2200AFF000XXX
	225	2250		XT4NU2225AFF000XXX
	250	2500		XT4NU2250AFF000XXX

7

XT4 250A TMF/TMA - Fixed (F) - 3 poles - Front terminals (F) - UL/CSA

Thermomagnetic trip unit			Int Rtnng (480 V)	N 25kA Part number	S 35kA Part number	H 65 kA Part number	L 100 kA Part number	V 150 kA Part number	X 200 kA Part number
Type	In	I _s							
TMF	25	400		XT4NU3025AFF000XXX	XT4SU3025AFF000XXX	XT4HU3025AFF000XXX	XT4LU3025AFF000XXX	XT4VU3025AFF000XXX	XT4XU3025AFF000XXX
	30	400		XT4NU3030AFF000XXX	XT4SU3030AFF000XXX	XT4HU3030AFF000XXX	XT4LU3030AFF000XXX	XT4VU3030AFF000XXX	XT4XU3030AFF000XXX
	35	400		XT4NU3035AFF000XXX	XT4SU3035AFF000XXX	XT4HU3035AFF000XXX	XT4LU3035AFF000XXX	XT4VU3035AFF000XXX	XT4XU3035AFF000XXX
	40	400		XT4NU3040AFF000XXX	XT4SU3040AFF000XXX	XT4HU3040AFF000XXX	XT4LU3040AFF000XXX	XT4VU3040AFF000XXX	XT4XU3040AFF000XXX
	50	500		XT4NU3050AFF000XXX	XT4SU3050AFF000XXX	XT4HU3050AFF000XXX	XT4LU3050AFF000XXX	XT4VU3050AFF000XXX	XT4XU3050AFF000XXX
	60	600		XT4NU3060AFF000XXX	XT4SU3060AFF000XXX	XT4HU3060AFF000XXX	XT4LU3060AFF000XXX	XT4VU3060AFF000XXX	XT4XU3060AFF000XXX
	70	700		XT4NU3070AFF000XXX	XT4SU3070AFF000XXX	XT4HU3070AFF000XXX	XT4LU3070AFF000XXX	XT4VU3070AFF000XXX	XT4XU3070AFF000XXX
	80	800		XT4NU3080AFF000XXX	XT4SU3080AFF000XXX	XT4HU3080AFF000XXX	XT4LU3080AFF000XXX	XT4VU3080AFF000XXX	XT4XU3080AFF000XXX
	90	900		XT4NU3090AFF000XXX	XT4SU3090AFF000XXX	XT4HU3090AFF000XXX	XT4LU3090AFF000XXX	XT4VU3090AFF000XXX	XT4XU3090AFF000XXX
	100	1000		XT4NU3100AFF000XXX	XT4SU3100AFF000XXX	XT4HU3100AFF000XXX	XT4LU3100AFF000XXX	XT4VU3100AFF000XXX	XT4XU3100AFF000XXX
	110	1100		XT4NU3110AFF000XXX	XT4SU3110AFF000XXX	XT4HU3110AFF000XXX	XT4LU3110AFF000XXX	XT4VU3110AFF000XXX	XT4XU3110AFF000XXX
	125	1250		XT4NU3125AFF000XXX	XT4SU3125AFF000XXX	XT4HU3125AFF000XXX	XT4LU3125AFF000XXX	XT4VU3125AFF000XXX	XT4XU3125AFF000XXX
	150	1500		XT4NU3150AFF000XXX	XT4SU3150AFF000XXX	XT4HU3150AFF000XXX	XT4LU3150AFF000XXX	XT4VU3150AFF000XXX	XT4XU3150AFF000XXX
	175	1750		XT4NU3175AFF000XXX	XT4SU3175AFF000XXX	XT4HU3175AFF000XXX	XT4LU3175AFF000XXX	XT4VU3175AFF000XXX	XT4XU3175AFF000XXX
	200	2000		XT4NU3200AFF000XXX	XT4SU3200AFF000XXX	XT4HU3200AFF000XXX	XT4LU3200AFF000XXX	XT4VU3200AFF000XXX	XT4XU3200AFF000XXX
	225	2250		XT4NU3225AFF000XXX	XT4SU3225AFF000XXX	XT4HU3225AFF000XXX	XT4LU3225AFF000XXX	XT4VU3225AFF000XXX	XT4XU3225AFF000XXX
	250	2500		XT4NU3250AFF000XXX	XT4SU3250AFF000XXX	XT4HU3250AFF000XXX	XT4LU3250AFF000XXX	XT4VU3250AFF000XXX	XT4XU3250AFF000XXX
TMA	56...80	400...800		XT4NU3080BFF000XXX	XT4SU3080BFF000XXX	XT4HU3080BFF000XXX	XT4LU3080BFF000XXX	XT4VU3080BFF000XXX	XT4XU3080BFF000XXX
	63...90	450...900		XT4NU3090BFF000XXX	XT4SU3090BFF000XXX	XT4HU3090BFF000XXX	XT4LU3090BFF000XXX	XT4VU3090BFF000XXX	XT4XU3090BFF000XXX
	70...100	500...1000		XT4NU3100BFF000XXX	XT4SU3100BFF000XXX	XT4HU3100BFF000XXX	XT4LU3100BFF000XXX	XT4VU3100BFF000XXX	XT4XU3100BFF000XXX
	77...110	550...1100		XT4NU3110BFF000XXX	XT4SU3110BFF000XXX	XT4HU3110BFF000XXX	XT4LU3110BFF000XXX	XT4VU3110BFF000XXX	XT4XU3110BFF000XXX
	87.5...125	625...1250		XT4NU3125BFF000XXX	XT4SU3125BFF000XXX	XT4HU3125BFF000XXX	XT4LU3125BFF000XXX	XT4VU3125BFF000XXX	XT4XU3125BFF000XXX
	105...150	750...1500		XT4NU3150BFF000XXX	XT4SU3150BFF000XXX	XT4HU3150BFF000XXX	XT4LU3150BFF000XXX	XT4VU3150BFF000XXX	XT4XU3150BFF000XXX
	122.5...175	875...1750		XT4NU3175BFF000XXX	XT4SU3175BFF000XXX	XT4HU3175BFF000XXX	XT4LU3175BFF000XXX	XT4VU3175BFF000XXX	XT4XU3175BFF000XXX
	140...200	1000...2000		XT4NU3200BFF000XXX	XT4SU3200BFF000XXX	XT4HU3200BFF000XXX	XT4LU3200BFF000XXX	XT4VU3200BFF000XXX	XT4XU3200BFF000XXX
	157.5...225	1125...2250		XT4NU3225BFF000XXX	XT4SU3225BFF000XXX	XT4HU3225BFF000XXX	XT4LU3225BFF000XXX	XT4VU3225BFF000XXX	XT4XU3225BFF000XXX
	175...250	1250...2500		XT4NU3250BFF000XXX	XT4SU3250BFF000XXX	XT4HU3250BFF000XXX	XT4LU3250BFF000XXX	XT4VU3250BFF000XXX	XT4XU3250BFF000XXX

Ordering codes for XT4 UL/CSA Circuit breakers

XT4 250A TMF/TMA - Fixed (F) - 4 poles - Front terminals (F) - UL/CSA

Thermomagnetic trip unit			Int Rtnng (480 V)	N	S	H	L	V	X
Type	In	I ₃		25kA Part number	35kA Part number	65kA Part number	100kA Part number	150kA Part number	200kA Part number
TMF	25	400		XT4NU4025AFF000XXX	XT4SU4025AFF000XXX	XT4HU4025AFF000XXX	XT4LU4025AFF000XXX	XT4VU4025AFF000XXX	XT4XU4025AFF000XXX
	30	400		XT4NU4030AFF000XXX	XT4SU4030AFF000XXX	XT4HU4030AFF000XXX	XT4LU4030AFF000XXX	XT4VU4030AFF000XXX	XT4XU4030AFF000XXX
	35	400		XT4NU4035AFF000XXX	XT4SU4035AFF000XXX	XT4HU4035AFF000XXX	XT4LU4035AFF000XXX	XT4VU4035AFF000XXX	XT4XU4035AFF000XXX
	40	400		XT4NU4040AFF000XXX	XT4SU4040AFF000XXX	XT4HU4040AFF000XXX	XT4LU4040AFF000XXX	XT4VU4040AFF000XXX	XT4XU4040AFF000XXX
	50	500		XT4NU4050AFF000XXX	XT4SU4050AFF000XXX	XT4HU4050AFF000XXX	XT4LU4050AFF000XXX	XT4VU4050AFF000XXX	XT4XU4050AFF000XXX
	60	600		XT4NU4060AFF000XXX	XT4SU4060AFF000XXX	XT4HU4060AFF000XXX	XT4LU4060AFF000XXX	XT4VU4060AFF000XXX	XT4XU4060AFF000XXX
	70	700		XT4NU4070AFF000XXX	XT4SU4070AFF000XXX	XT4HU4070AFF000XXX	XT4LU4070AFF000XXX	XT4VU4070AFF000XXX	XT4XU4070AFF000XXX
TMA	56...80	400...800		XT4NU4080BFF000XXX	XT4SU4080BFF000XXX	XT4HU4080BFF000XXX	XT4LU4080BFF000XXX	XT4VU4080BFF000XXX	XT4XU4080BFF000XXX
	63...90	450...900		XT4NU4090BFF000XXX	XT4SU4090BFF000XXX	XT4HU4090BFF000XXX	XT4LU4090BFF000XXX	XT4VU4090BFF000XXX	XT4XU4090BFF000XXX
	70...100	500...1000		XT4NU4100BFF000XXX	XT4SU4100BFF000XXX	XT4HU4100BFF000XXX	XT4LU4100BFF000XXX	XT4VU4100BFF000XXX	XT4XU4100BFF000XXX
	77...110	550...1100		XT4NU4110BFF000XXX	XT4SU4110BFF000XXX	XT4HU4110BFF000XXX	XT4LU4110BFF000XXX	XT4VU4110BFF000XXX	XT4XU4110BFF000XXX
	87.5...125	625...1250		XT4NU4125BFF000XXX	XT4SU4125BFF000XXX	XT4HU4125BFF000XXX	XT4LU4125BFF000XXX	XT4VU4125BFF000XXX	XT4XU4125BFF000XXX
	105...150	750...1500		XT4NU4150BFF000XXX	XT4SU4150BFF000XXX	XT4HU4150BFF000XXX	XT4LU4150BFF000XXX	XT4VU4150BFF000XXX	XT4XU4150BFF000XXX
	122.5...175	875...1750		XT4NU4175BFF000XXX	XT4SU4175BFF000XXX	XT4HU4175BFF000XXX	XT4LU4175BFF000XXX	XT4VU4175BFF000XXX	XT4XU4175BFF000XXX
	140...200	1000...2000		XT4NU4200BFF000XXX	XT4SU4200BFF000XXX	XT4HU4200BFF000XXX	XT4LU4200BFF000XXX	XT4VU4200BFF000XXX	XT4XU4200BFF000XXX
	157.5...225	1125...2250		XT4NU4225BFF000XXX	XT4SU4225BFF000XXX	XT4HU4225BFF000XXX	XT4LU4225BFF000XXX	XT4VU4225BFF000XXX	XT4XU4225BFF000XXX
	175...250	1250...2500		XT4NU4250BFF000XXX	XT4SU4250BFF000XXX	XT4HU4250BFF000XXX	XT4LU4250BFF000XXX	XT4VU4250BFF000XXX	XT4XU4250BFF000XXX

7

XT4 250A MCP (MA) - Fixed (F) - 3 poles - Front terminals (F) - UL/CSA

Magnetic trip unit			Int Rtnng (480 V)	H					
Type	In	I ₃		65kA Part number					
MCP	25	75...275		XT4HU3025MFF000XXX					
	50	150...550		XT4HU3050MFF000XXX					
	80	400...800		XT4HU3080MFF000XXX					
	100	500...7000		XT4HU3100MFF000XXX					
	110	550...1100		XT4HU3110MFF000XXX					
	125	625...1250		XT4HU3125MFF000XXX					
	150	750...1500		XT4HU3150MFF000XXX					
	175	875...1750		XT4HU3175MFF000XXX					
	200	1000...2000		XT4HU3200MFF000XXX					
	225	1125...2250		XT4HU3225MFF000XXX					
	250	1250...2500		XT4HU3250MFF000XXX					

XT4 250A Ekip - Fixed (F) - 3 poles - Front terminals (F) - UL/CSA

Ekip electronic trip units		Int Rtnng (480 V)	N 25kA Part number	S 35kA Part number	H 65kA Part number	L 100kA Part number	V 150kA Part number	X ⁽¹⁾ 200kA Part number
Type	In							
Ekip LS/I	40		XT4NU3040EFF000XXX	XT4SU3040EFF000XXX	XT4HU3040EFF000XXX	XT4LU3040EFF000XXX	XT4VU3040EFF000XXX	XT4XU3040EFF000XXX
	60		XT4NU3060EFF000XXX	XT4SU3060EFF000XXX	XT4HU3060EFF000XXX	XT4LU3060EFF000XXX	XT4VU3060EFF000XXX	XT4XU3060EFF000XXX
	100		XT4NU3100EFF000XXX	XT4SU3100EFF000XXX	XT4HU3100EFF000XXX	XT4LU3100EFF000XXX	XT4VU3100EFF000XXX	XT4XU3100EFF000XXX
	150		XT4NU3150EFF000XXX	XT4SU3150EFF000XXX	XT4HU3150EFF000XXX	XT4LU3150EFF000XXX	XT4VU3150EFF000XXX	XT4XU3150EFF000XXX
	225		XT4NU3225EFF000XXX	XT4SU3225EFF000XXX	XT4HU3225EFF000XXX	XT4LU3225EFF000XXX	XT4VU3225EFF000XXX	XT4XU3225EFF000XXX
	250		XT4NU3250EFF000XXX	XT4SU3250EFF000XXX	XT4HU3250EFF000XXX	XT4LU3250EFF000XXX	XT4VU3250EFF000XXX	XT4XU3250EFF000XXX
Ekip LSI	40		XT4NU3040FFF000XXX	XT4SU3040FFF000XXX	XT4HU3040FFF000XXX	XT4LU3040FFF000XXX	XT4VU3040FFF000XXX	XT4XU3040FFF000XXX
	60		XT4NU3060FFF000XXX	XT4SU3060FFF000XXX	XT4HU3060FFF000XXX	XT4LU3060FFF000XXX	XT4VU3060FFF000XXX	XT4XU3060FFF000XXX
	100		XT4NU3100FFF000XXX	XT4SU3100FFF000XXX	XT4HU3100FFF000XXX	XT4LU3100FFF000XXX	XT4VU3100FFF000XXX	XT4XU3100FFF000XXX
	150		XT4NU3150FFF000XXX	XT4SU3150FFF000XXX	XT4HU3150FFF000XXX	XT4LU3150FFF000XXX	XT4VU3150FFF000XXX	XT4XU3150FFF000XXX
	225		XT4NU3225FFF000XXX	XT4SU3225FFF000XXX	XT4HU3225FFF000XXX	XT4LU3225FFF000XXX	XT4VU3225FFF000XXX	XT4XU3225FFF000XXX
	250		XT4NU3250FFF000XXX	XT4SU3250FFF000XXX	XT4HU3250FFF000XXX	XT4LU3250FFF000XXX	XT4VU3250FFF000XXX	XT4XU3250FFF000XXX
Ekip LSIG	40		XT4NU3040GFF000XXX	XT4SU3040GFF000XXX	XT4HU3040GFF000XXX	XT4LU3040GFF000XXX	XT4VU3040GFF000XXX	XT4XU3040GFF000XXX
	60		XT4NU3060GFF000XXX	XT4SU3060GFF000XXX	XT4HU3060GFF000XXX	XT4LU3060GFF000XXX	XT4VU3060GFF000XXX	XT4XU3060GFF000XXX
	100		XT4NU3100GFF000XXX	XT4SU3100GFF000XXX	XT4HU3100GFF000XXX	XT4LU3100GFF000XXX	XT4VU3100GFF000XXX	XT4XU3100GFF000XXX
	150		XT4NU3150GFF000XXX	XT4SU3150GFF000XXX	XT4HU3150GFF000XXX	XT4LU3150GFF000XXX	XT4VU3150GFF000XXX	XT4XU3150GFF000XXX
	225		XT4NU3225GFF000XXX	XT4SU3225GFF000XXX	XT4HU3225GFF000XXX	XT4LU3225GFF000XXX	XT4VU3225GFF000XXX	XT4XU3225GFF000XXX
	250		XT4NU3250GFF000XXX	XT4SU3250GFF000XXX	XT4HU3250GFF000XXX	XT4LU3250GFF000XXX	XT4VU3250GFF000XXX	XT4XU3250GFF000XXX
Ekip E-LSIG	40		XT4NU3040HFF000XXX	XT4SU3040HFF000XXX	XT4HU3040HFF000XXX	XT4LU3040HFF000XXX	XT4VU3040HFF000XXX	-
	60		XT4NU3060HFF000XXX	XT4SU3060HFF000XXX	XT4HU3060HFF000XXX	XT4LU3060HFF000XXX	XT4VU3060HFF000XXX	-
	100		XT4NU3100HFF000XXX	XT4SU3100HFF000XXX	XT4HU3100HFF000XXX	XT4LU3100HFF000XXX	XT4VU3100HFF000XXX	-
	150		XT4NU3150HFF000XXX	XT4SU3150HFF000XXX	XT4HU3150HFF000XXX	XT4LU3150HFF000XXX	XT4VU3150HFF000XXX	-
	225		XT4NU3225HFF000XXX	XT4SU3225HFF000XXX	XT4HU3225HFF000XXX	XT4LU3225HFF000XXX	XT4VU3225HFF000XXX	-
	250		XT4NU3250HFF000XXX	XT4SU3250HFF000XXX	XT4HU3250HFF000XXX	XT4LU3250HFF000XXX	XT4VU3250HFF000XXX	-
Ekip I	40		XT4NU3040JFF000XXX	XT4SU3040JFF000XXX	XT4HU3040JFF000XXX	XT4LU3040JFF000XXX	XT4VU3040JFF000XXX	XT4XU3040JFF000XXX
	60		XT4NU3060JFF000XXX	XT4SU3060JFF000XXX	XT4HU3060JFF000XXX	XT4LU3060JFF000XXX	XT4VU3060JFF000XXX	XT4XU3060JFF000XXX
	100		XT4NU3100JFF000XXX	XT4SU3100JFF000XXX	XT4HU3100JFF000XXX	XT4LU3100JFF000XXX	XT4VU3100JFF000XXX	XT4XU3100JFF000XXX
	150		XT4NU3150JFF000XXX	XT4SU3150JFF000XXX	XT4HU3150JFF000XXX	XT4LU3150JFF000XXX	XT4VU3150JFF000XXX	XT4XU3150JFF000XXX
	225		XT4NU3225JFF000XXX	XT4SU3225JFF000XXX	XT4HU3225JFF000XXX	XT4LU3225JFF000XXX	XT4VU3225JFF000XXX	XT4XU3225JFF000XXX
	250		XT4NU3250JFF000XXX	XT4SU3250JFF000XXX	XT4HU3250JFF000XXX	XT4LU3250JFF000XXX	XT4VU3250JFF000XXX	XT4XU3250JFF000XXX
Ekip M-LIU	40		-	-	XT4HU3040LFF000XXX	-	-	-
	60		-	-	XT4HU3060LFF000XXX	-	-	-
	100		-	-	XT4HU3100LFF000XXX	-	-	-
	150		-	-	XT4HU3150LFF000XXX	-	-	-

⁽¹⁾Consult ABB for availability.

Ordering codes for XT4 UL/CSA

Circuit breakers

XT4 250A Ekip - Fixed (F) - 4 poles - Front terminals (F) - UL/CSA

Ekip electronic trip units		Int Rtnng (480 V)	N 25kA Part number	S 35kA Part number	H 65kA Part number	L 100kA Part number	V 150kA Part number	X ⁽¹⁾ 200kA Part number
Type	In							
Ekip LS/I	40		XT4NU4040EFF000XXX	XT4SU4040EFF000XXX	XT4HU4040EFF000XXX	XT4LU4040EFF000XXX	XT4VU4040EFF000XXX	XT4XU4040EFF000XXX
	60		XT4NU4060EFF000XXX	XT4SU4060EFF000XXX	XT4HU4060EFF000XXX	XT4LU4060EFF000XXX	XT4VU4060EFF000XXX	XT4XU4060EFF000XXX
	100		XT4NU4100EFF000XXX	XT4SU4100EFF000XXX	XT4HU4100EFF000XXX	XT4LU4100EFF000XXX	XT4VU4100EFF000XXX	XT4XU4100EFF000XXX
	150		XT4NU4150EFF000XXX	XT4SU4150EFF000XXX	XT4HU4150EFF000XXX	XT4LU4150EFF000XXX	XT4VU4150EFF000XXX	XT4XU4150EFF000XXX
	225		XT4NU4225EFF000XXX	XT4SU4225EFF000XXX	XT4HU4225EFF000XXX	XT4LU4225EFF000XXX	XT4VU4225EFF000XXX	XT4XU4225EFF000XXX
	250		XT4NU4250EFF000XXX	XT4SU4250EFF000XXX	XT4HU4250EFF000XXX	XT4LU4250EFF000XXX	XT4VU4250EFF000XXX	XT4XU4250EFF000XXX
Ekip LSI	40		XT4NU4040FFF000XXX	XT4SU4040FFF000XXX	XT4HU4040FFF000XXX	XT4LU4040FFF000XXX	XT4VU4040FFF000XXX	XT4XU4040FFF000XXX
	60		XT4NU4060FFF000XXX	XT4SU4060FFF000XXX	XT4HU4060FFF000XXX	XT4LU4060FFF000XXX	XT4VU4060FFF000XXX	XT4XU4060FFF000XXX
	100		XT4NU4100FFF000XXX	XT4SU4100FFF000XXX	XT4HU4100FFF000XXX	XT4LU4100FFF000XXX	XT4VU4100FFF000XXX	XT4XU4100FFF000XXX
	150		XT4NU4150FFF000XXX	XT4SU4150FFF000XXX	XT4HU4150FFF000XXX	XT4LU4150FFF000XXX	XT4VU4150FFF000XXX	XT4XU4150FFF000XXX
	225		XT4NU4225FFF000XXX	XT4SU4225FFF000XXX	XT4HU4225FFF000XXX	XT4LU4225FFF000XXX	XT4VU4225FFF000XXX	XT4XU4225FFF000XXX
	250		XT4NU4250FFF000XXX	XT4SU4250FFF000XXX	XT4HU4250FFF000XXX	XT4LU4250FFF000XXX	XT4VU4250FFF000XXX	XT4XU4250FFF000XXX
Ekip LSIG	40		XT4NU4040GFF000XXX	XT4SU4040GFF000XXX	XT4HU4040GFF000XXX	XT4LU4040GFF000XXX	XT4VU4040GFF000XXX	XT4XU4040GFF000XXX
	60		XT4NU4060GFF000XXX	XT4SU4060GFF000XXX	XT4HU4060GFF000XXX	XT4LU4060GFF000XXX	XT4VU4060GFF000XXX	XT4XU4060GFF000XXX
	100		XT4NU4100GFF000XXX	XT4SU4100GFF000XXX	XT4HU4100GFF000XXX	XT4LU4100GFF000XXX	XT4VU4100GFF000XXX	XT4XU4100GFF000XXX
	150		XT4NU4150GFF000XXX	XT4SU4150GFF000XXX	XT4HU4150GFF000XXX	XT4LU4150GFF000XXX	XT4VU4150GFF000XXX	XT4XU4150GFF000XXX
	225		XT4NU4225GFF000XXX	XT4SU4225GFF000XXX	XT4HU4225GFF000XXX	XT4LU4225GFF000XXX	XT4VU4225GFF000XXX	XT4XU4225GFF000XXX
	250		XT4NU4250GFF000XXX	XT4SU4250GFF000XXX	XT4HU4250GFF000XXX	XT4LU4250GFF000XXX	XT4VU4250GFF000XXX	XT4XU4250GFF000XXX
Ekip E-LSIG	40		XT4NU4040HFF000XXX	XT4SU4040HFF000XXX	XT4HU4040HFF000XXX	XT4LU4040HFF000XXX	XT4VU4040HFF000XXX	-
	60		XT4NU4060HFF000XXX	XT4SU4060HFF000XXX	XT4HU4060HFF000XXX	XT4LU4060HFF000XXX	XT4VU4060HFF000XXX	-
	100		XT4NU4100HFF000XXX	XT4SU4100HFF000XXX	XT4HU4100HFF000XXX	XT4LU4100HFF000XXX	XT4VU4100HFF000XXX	-
	150		XT4NU4150HFF000XXX	XT4SU4150HFF000XXX	XT4HU4150HFF000XXX	XT4LU4150HFF000XXX	XT4VU4150HFF000XXX	-
	225		XT4NU4225HFF000XXX	XT4SU4225HFF000XXX	XT4HU4225HFF000XXX	XT4LU4225HFF000XXX	XT4VU4225HFF000XXX	-
	250		XT4NU4250HFF000XXX	XT4SU4250HFF000XXX	XT4HU4250HFF000XXX	XT4LU4250HFF000XXX	XT4VU4250HFF000XXX	-
Ekip I	40		XT4NU4040JFF000XXX	XT4SU4040JFF000XXX	XT4HU4040JFF000XXX	XT4LU4040JFF000XXX	XT4VU4040JFF000XXX	XT4XU4040JFF000XXX
	60		XT4NU4060JFF000XXX	XT4SU4060JFF000XXX	XT4HU4060JFF000XXX	XT4LU4060JFF000XXX	XT4VU4060JFF000XXX	XT4XU4060JFF000XXX
	100		XT4NU4100JFF000XXX	XT4SU4100JFF000XXX	XT4HU4100JFF000XXX	XT4LU4100JFF000XXX	XT4VU4100JFF000XXX	XT4XU4100JFF000XXX
	150		XT4NU4150JFF000XXX	XT4SU4150JFF000XXX	XT4HU4150JFF000XXX	XT4LU4150JFF000XXX	XT4VU4150JFF000XXX	XT4XU4150JFF000XXX
	225		XT4NU4225JFF000XXX	XT4SU4225JFF000XXX	XT4HU4225JFF000XXX	XT4LU4225JFF000XXX	XT4VU4225JFF000XXX	XT4XU4225JFF000XXX
	250		XT4NU4250JFF000XXX	XT4SU4250JFF000XXX	XT4HU4250JFF000XXX	XT4LU4250JFF000XXX	XT4VU4250JFF000XXX	XT4XU4250JFF000XXX

⁽¹⁾Consult ABB for availability.

XT4 250A switch - Fixed (F) - 3 poles - Front terminals (F) - UL/CSA

No trip unit			Int Rtnng (480 V)	N 25kA Part number	S 35kA Part number	H 65kA Part number	L 100kA Part number	V 150kA Part number
Type	In	Mag. Override						
XT4-D	250	2500		XT4NU3250DFF000XXX	XT4SU3250DFF000XXX	XT4HU3250DFF000XXX	XT4LU3250DFF000XXX	XT4VU3250DFF000XXX

XT4 250A switch - Fixed (F) - 4 poles - Front terminals (F) - UL/CSA

No trip unit			Int Rtnng (480 V)	N 25kA Part number	S 35kA Part number	H 65kA Part number	L 100kA Part number	V 150kA Part number
Type	In	Mag. Override						
XT4-D	250	2500		XT4NU4250DFF000XXX	XT4SU4250DFF000XXX	XT4HU4250DFF000XXX	XT4LU4250DFF000XXX	XT4VU4250DFF000XXX

XT4 250A Breaking part - UL/CSA

Type	Int Rtnng (480 V)	N 25kA Part number	S 35kA Part number	H 65kA Part number	L 100kA Part number	V 150kA Part number
XT4 250A breaking part - 3p		KXT4BP3N250	KXT4BP3S250	KXT4BP3H250	KXT4BP3L250	KXT4BP3V250
XT4 250A breaking part - 4p		KXT4BP4N250	KXT4BP4S250	KXT4BP4H250	KXT4BP4L250	KXT4BP4V250

XT4 250A Loose trip unit - UL/CSA

Thermal magnetic trip unit			3p	4p		
Type	In	I _g	Part number	Part number		
TMF	25	400	KXT4TU3TMF25	KXT4TU4TMF25		
	30	400	KXT4TU3TMF30	KXT4TU4TMF30		
	35	400	KXT4TU3TMF35	KXT4TU4TMF35		
	40	400	KXT4TU3TMF40	KXT4TU4TMF40		
	50	500	KXT4TU3TMF50	KXT4TU4TMF50		
	60	600	KXT4TU3TMF60	KXT4TU4TMF60		
	70	700	KXT4TU3TMF70	KXT4TU4TMF70		
	80	800	KXT4TU3TMF80	-		
	90	900	KXT4TU3TMF90	-		
	100	1000	KXT4TU3TMF100	-		
	110	110	KXT4TU3TMF110	-		
	125	1250	KXT4TU3TMF125	-		
	150	1500	KXT4TU3TMF150	-		
	175	1750	KXT4TU3TMF175	-		
	200	2000	KXT4TU3TMF200	-		
225	2250	KXT4TU3TMF225	-			
250	2500	KXT4TU3TMF250	-			
TMA	56...80	400...800	KXT4TU3TMA80	KXT4TU4TMA80		
	63...90	450...900	KXT4TU3TMA90	KXT4TU4TMA90		
	70...100	500...1000	KXT4TU3TMA100	KXT4TU4TMA100		
	77...110	550...1100	KXT4TU3TMA110	KXT4TU4TMA110		
	87.5...125	625...1250	KXT4TU3TMA125	KXT4TU4TMA125		
	105...150	750...1500	KXT4TU3TMA150	KXT4TU4TMA150		
	122.5...175	875...1750	KXT4TU3TMA175	KXT4TU4TMA175		
	140...200	1000...2000	KXT4TU3TMA200	KXT4TU4TMA200		
	157.5...225	1125...2250	KXT4TU3TMA225	KXT4TU4TMA225		
	175...250	1250...2500	KXT4TU3TMA250	KXT4TU4TMA250		

Ordering codes for XT4 UL/CSA Circuit breakers

XT4 250A Loose trip unit - UL/CSA

Ekip electronic trip units		3p	4p
Type	In	Part number	Part number
Ekip LS/I	40	KXT4TU3LS/I40	KXT4TU4LS/I40
	60	KXT4TU3LS/I60	KXT4TU4LS/I60
	100	KXT4TU3LS/I100	KXT4TU4LS/I100
	150	KXT4TU3LS/I150	KXT4TU4LS/I150
	225	KXT4TU3LS/I225	KXT4TU4LS/I225
	250	KXT4TU3LS/I250	KXT4TU4LS/I250
Ekip LSI	40	KXT4TU3LSI40	KXT4TU4LSI40
	60	KXT4TU3LSI60	KXT4TU4LSI60
	100	KXT4TU3LSI100	KXT4TU4LSI100
	150	KXT4TU3LSI150	KXT4TU4LSI150
	225	KXT4TU3LSI225	KXT4TU4LSI225
	250	KXT4TU3LSI250	KXT4TU4LSI250
Ekip LSIG	40	KXT4TU3LSIG40	KXT4TU4LSIG40
	60	KXT4TU3LSIG60	KXT4TU4LSIG60
	100	KXT4TU3LSIG100	KXT4TU4LSIG100
	150	KXT4TU3LSIG150	KXT4TU4LSIG150
	225	KXT4TU3LSIG225	KXT4TU4LSIG225
	250	KXT4TU3LSIG250	KXT4TU4LSIG250
Ekip E-LSIG	40	KXT4TU3E-LSIG40	KXT4TU4E-LSIG40
	60	KXT4TU3E-LSIG60	KXT4TU3E-LSIG60
	100	KXT4TU3E-LSIG100	KXT4TU4E-LSIG100
	150	KXT4TU3E-LSIG150	KXT4TU4E-LSIG150
	225	KXT4TU3E-LSIG225	KXT4TU4E-LSIG225
	250	KXT4TU3E-LSIG250	KXT4TU4E-LSIG250
Ekip I	40	KXT4TU3I40	KXT4TU4I40
	60	KXT4TU3I60	KXT4TU4I60
	100	KXT4TU3I100	KXT4TU4I100
	150	KXT4TU3I150	KXT4TU4I150
	225	KXT4TU3I225	KXT4TU4I225
	250	KXT4TU3I250	KXT4TU4I250

Ordering codes for XT4 UL/CSA Accessories



Fixed part of plug-in



Fixed part of withdrawable



Conversion kit for turning a fixed circuit breaker into the moving part of a plug-in circuit breaker



Conversion kit for turning a fixed circuit breaker into the moving part of a withdrawable circuit breaker

Fixed parts, conversion kits and accessories for fixed parts

Fixed part of plug-in (P)

Type	3p Part number	4p Part number
Kit P FP E	KXT4PFPEF-3	KXT4PFPEF-4
Kit P FP HR/VR ⁽¹⁾	KXT4EPFPHR-3	KXT4EPFPHR-4

⁽¹⁾IEC rated only. The terminals are factory-mounted in the horizontal position (HR).

Fixed part of withdrawable (W)

Type	3p Part number	4p Part number
Kit W FP EF	KXT4WFPEF-3	KXT4WFPEF-4
Kit W FP HR/VR ⁽¹⁾	KXT4EWFPHR-3	KXT4EWFPHR-4

⁽¹⁾IEC rated only. The terminals are factory-mounted in the horizontal position (HR).

Fixed part terminals⁽¹⁾

Type	3p Part number	4p Part number
EF - Front extended terminals	KXT4EEFFP-3	KXT4EEFFP-4
R - Rear terminals HR/VR	KXTEERFP-3	KXTEERFP-4
PS - Rear phase separators 90mm/3.54in	KXTAEPB90-3	KXTAEPB90-4

⁽¹⁾IEC rated only.

Conversion kit of the circuit breaker from fixed into moving part of plug-in

Type	3p Part number	4p Part number
P MP kit	KXT4PMP-3	KXT4PMP-4

Conversion kit of the circuit breaker from fixed into moving part of withdrawable

Type	3p Part number	4p Part number
W MP kit	KXT4WMP-3	KXT4WMP-4

Conversion Kit of the fixed part from plug-in to withdrawable

Type	Part number
FP P>W kit	KXT4FPPtoFPW

Ordering codes for XT4 UL/CSA Accessories

Conversion Kit of the RC Sel from fixed to plug-in⁽¹⁾

Type	3p Part number	4p Part number
P MP RC Sel 4p KIT		KXT4EPMPRC-4

⁽¹⁾IEC rated only.

Conversion Kit of RC Sel from plug-in to withdrawable⁽¹⁾

Type	3p Part number	4p Part number
W MP RC Sel 4p KIT	-	KXT4EWMPRC-4

⁽¹⁾IEC rated only.



Key lock/padlock for fixed part

Key lock for fixed part of withdrawable⁽¹⁾

Type	Part number
KL-D Key Lock FP, different keys	KXTCEKLD FPW
KL-S Key Lock FP, same keys N.20005	KXTCEKLS FPW

⁽¹⁾IEC rated only.



Ronis key lock/padlock for fixed part

Ronis key lock for fixed part of withdrawable⁽¹⁾

Type	Part number
KL-D Ronis FP key lock, different keys	KXTCEKLD RonFPW
KL-S Ronis FP key lock, same Type A keys	KXTCEKLS RonFPW

⁽¹⁾IEC rated only.



Fixed part adapter

Adapter for mounting the terminals of the fixed circuit breaker on the fixed part

Type	3p Part number	4p Part number
ADP adapter for fixed part (2 pieces)	KXT4ADP-3	KXT4ADP-4

Note: When using ADP with ES/MC terminals, also order "Kit F Front Terminals".

Service releases



SOR uncabled



SOR cabled



SOR for withdrawable



UVR uncabled



UVR cabled



SOR for withdrawable



Time delay device for undervoltage release

Shunt opening release - SOR

Type	Fixed/Plug-in Part number	Withdrawable Part number		
Uncabled version				
SOR 12V DC	KXTASORA	-		
SOR 24-30V AC/DC	KXTASORB	-		
SOR 48-60V AC/DC	KXTASORC	-		
SOR 110...127V AC / 110...125V DC	KXTASORD	-		
SOR 220...240V AC / 220...250V DC	KXTASORE	-		
SOR 380-440V AC	KXTASORF	-		
SOR 480-525V AC	KXTASORG	-		
Cabled version				
SOR-C 12V DC	KXTASORCFPA	KXTCSORCWA		
SOR-C 24-30V AC/DC	KXTASORCFPB	KXTCSORCWB		
SOR-C 48-60V AC/DC	KXTASORCFPC	KXTCSORCWC		
SOR-C 110...127V AC / 110...125V DC	KXTASORCFPD	KXTCSORCWD		
SOR-C 220...240V AC / 220...250V DC	KXTASORCFPE	KXTCSORCWE		
SOR-C 380-440V AC	KXTASORCFPF	KXTCSORCWF		
SOR-C 480-525V AC	KXTASORCFPG	KXTCSORCWG		

Undervoltage release - UVR

Type	Fixed/Plug-in Part number	Withdrawable Part number		
Uncabled version				
UVR 24-30V AC/DC	KXTAUVR1	-		
UVR 48V AC/DC	KXTAUVR2	-		
UVR 60V AC/DC	KXTAUVR3	-		
UVR 110...127V AC / 110...125V DC	KXTAUVR4	-		
UVR 220...240V AC / 220...250V DC	KXTAUVR5	-		
UVR 380-440V AC	KXTAUVR6	-		
UVR 480-525V AC	KXTAUVR7	-		
Cabled version				
UVR-C 24-30V AC/DC	KXTAUVRCFP1	KXTCUVRWC1		
UVR-C 48V AC/DC	KXTAUVRCFP2	KXTCUVRWC2		
UVR-C 60V AC/DC	KXTAUVRCFP3	KXTCUVRWC3		
UVR-C 110...127V AC / 110...125V DC	KXTAUVRCFP4	KXTCUVRWC4		
UVR-C 220...240V AC / 220...250V DC	KXTAUVRCFP5	KXTCUVRWC5		
UVR-C 380-440V AC	KXTAUVRCFP6	KXTCUVRWC6		
UVR-C 480-525V AC	KXTAUVRCFP7	KXTCUVRWC7		

Delay device for undervoltage release - UVD⁽¹⁾

Type	Part number			
UVD 24...30V AC/DC	KT3UVD8			
UVD 48...60V AC/DC	KT3UVD7			
UVD 110...125V AC/DC	KT3UVD4			
UVD 220...250V AC/DC	KT3UVD2			

⁽¹⁾IEC rated only.

Ordering codes for XT4 UL/CSA Accessories

Connectors

Fourth pole connectors for withdrawable⁽¹⁾

Type	Part number		
Connector 4 th pole SOR	KXTCE3PINCONSOR		
Connector 4 th pole UVR	KXTCE3PINCONUVR		

⁽¹⁾IEC rated only.

Socket-plug connector on the panel⁽¹⁾

Type	Part number		
Socket-plug connector with 3 PINS	KXTAE3PINCON		
Socket-plug connector with 6 PINS	KXTAE6PINCON		
Socket-plug connector with 9 PINS	KXTAE9PINCON		
Socket-plug connector with 15 PINS	KXTAE15PINCON		

⁽¹⁾IEC rated only.

Fixed part socket-plug connector⁽¹⁾

Type	Part number		
Socket-plug connector of moving part - 12 PINS	KXTCE12PINMPCON		
Socket-plug connector of fixed part - 12 PINS	KXTCE12PINFPCON		

⁽¹⁾IEC rated only.



Socket-plug connector of fixed part

7

Electrical signals

Auxiliary contacts - AUX

Type	Fixed/Plug-in Part number	Withdrawable Part number	
Uncabled version			
AUX 250V	KXTAAUX	-	
AUX 24V DC	KXTAAUXD	-	
AUX-S51 250V	KXTCAXS51	-	
AUX-S51 24V DC	KXTCAXDS51	-	
Cabled version			
AUX-C 3 Q 250V left	KXTCAXC3QL	-	
AUX-C 1 Q + 1 SY 250V	KXTAAXCQSYFP	KXTCAXCQSYW	
AUX-C 2 Q + 1 SY 250V	KXTAAXC2QSYFP	-	
AUX-C 3 Q + 1 SY 250V	KXTDAXC3QSYFP	KXTCAXC3QSYW	
AUX-C 3 Q + 2 SY 250V	KXTCAXC3Q2SYFP	KXTCAXC3Q2SYW	
AUX-C 2 Q + 2 SY + 1 S51 250V	KXTCAXC2Q2SYS51FP	KXTCAXC2Q2SYS51W	
AUX-S51-C 250V	KXTCAXCS51FP	KXTCAXCS51W	
AUX-C 1 Q + 1 SY 24V DC	KXTAAXCDQSYFP	KXTCAXCDQSYW	
AUX-C 3 Q + 1 SY 24V DC	KXTDAXCD3QSYFP	KXTCAXCD3QSYW	
AUX-S51-C 24V DC	KXTCAXDS51FP	KXTCAXDS51W	
AUX-C 1 Q + 1 SY 400V AC	KXTCAXC4QSYFP	KXTCAXC4QSYW	
AUX-C 2 Q 400V AC	KXTCAXC42QFP	KXTCAXC42QW	



AUX uncabled



AUX cabled



AUX for withdrawable



AUP - Auxiliary position contacts

Auxiliary position contacts - AUP

Type	Part number		
Cabled version			
AUP-I - Four racked-in contacts 250V for plug-in circuit breaker	KXTAAUP250IN		
AUP-I - Four racked-in contacts 24V DC for plug-in circuit breaker	KXTAAUP24IN		
AUP-R - Two racked-out contacts 250V for withdrawable circuit breaker	KXTCAUP250W		
AUP-R - Two racked-out contacts 24V DC for withdrawable circuit breaker	KXTCAUP24W		



AUE - Early auxiliary contacts

Early auxiliary contacts - AUE

Type	Fixed/Plug-in Part number	Withdrawable Part number	
AUE – Two contacts in the rotary handle RHx (Closed)	KXTAAUECLFP	KXTCAUECLW	
AUE – Two contacts in the rotary handle RHx (Open)	KXTDAUEOPFP	KXTCAUEOPW	

Motor operators



MOE - Motor operator

Stored energy motor operator - MOE

Type	Part number		
MOE 24V DC	KXTCMOE24		
MOE 48...60V DC	KXTCMOE48-60		
MOE 110...125V AC/DC	KXTCMOE110-125		
MOE 220...250V AC/DC	KXTCMOE220-250		
MOE 380...440V AC	KXTCMOE380-440		
MOE 480...525V AC	KXTCMOE480-525		

Electronic stored energy motor operator - MOE-E⁽¹⁾

Type	Part number		
MOE-E 24V DC	KXTCMOEE24		
MOE-E 48...60V DC	KXTCMOEE48-60		
MOE-E 110...125V AC/DC	KXTCMOEE110-125		
MOE-E 220...250V AC/DC	KXTCMOEE220-250		
MOE-E 380...440V AC	KXTCMOEE380-440		
MOE-E 480...525V AC	KXTCMOEE480-525		

⁽¹⁾IEC rated only.

Ordering codes for XT4 UL/CSA Accessories

Rotary handle operating mechanisms



Direct rotary handle



Extended rotary handle

7

Rotary handle operating mechanisms

Type	Fixed/Plug-In Part number	Withdrawable Part number	
RHD Standard Direct Handle	KXTCRHDSTFP	KXTCRHDSTW	
RHD Emergency Direct Handle	KXTCRHDEMFP	KXTCRHDEMW	
RHE Standard Extended Handle	KXTCRHESTFP	KXTCRHESTW	
RHE Emergency Extended Handle	KXTCRHEEMFP	KXTCRHEEMW	
RHE Standard Extended Handle with Padlock ⁽¹⁾	KXTCRHESTFPPLK	KXTCRHESTWPLK	
RHE Emergency Extended Handle with Padlock ⁽¹⁾	KXTCRHEEMFPPLK	KXTCRHEEMWPLK	
RHS-L Standard Left Side Handle	KXTCRHSLSSTFP	-	
RHS-L Emergency Left Side Handle	KXTCRHSLEMFP	-	
RHS-R Standard Right Side Handle	KXTCRHSRSSTFP	-	
RHS-R Emergency Right Side Handle	KXTCRHSREMFP	-	
Extended Handle Spare Parts			
RHE-B Base for Extended Handle	KXTCRHEBFP	KXTCRHEBW	
RHE-B Base for Extended Handle with Padlock ⁽¹⁾	KXTCRHEBFPPLK	KXTCRHEBWPLK	
RHE-S 500mm Shaft	KXTARHES500	KXTARHES500	
RHE-H Standard Extended Handle	KXTARHEHST	KXTARHEHST	
RHE-H Emergency Extended Handle	KXTARHEHEM	KXTARHEHEM	
LH Standard Large Handle, NEMA 1	KXTALHNDLST	KXTALHNDLST	
LH Emergency Large Handle, NEMA 1	KXTALHNDLEM	KXTALHNDLEM	
Standard Pistol Handle with reset function, 65mm, NEMA 3R, 12	OHB65J10B	OHB65J10B	
Emergency Pistol Handle with reset function, 65mm, NEMA 3R, 12 ⁽¹⁾	OHY65J10B	OHY65J10B	
Standard Pistol Handle with reset function, 65mm, NEMA 4, 4X ⁽¹⁾	OHB65L10B	OHB65L10B	
Emergency Pistol Handle with reset function, 65mm, NEMA 4, 4X ⁽¹⁾	OHY65L10B	OHY65L10B	
Standard Pistol Handle with reset function, 125mm, NEMA 3R, 12	OHB125J10B	OHB125J10B	
Emergency Pistol Handle with reset function, 125mm, NEMA 3R, 12 ⁽¹⁾	OHY125J10B	OHY125J10B	
Standard Pistol Handle with reset function, 125mm, NEMA 4, 4X ⁽¹⁾	OHB125L10B	OHB125L10B	
Emergency Pistol Handle with reset function, 125mm, NEMA 4, 4X ⁽¹⁾	OHY125L10B	OHY125L10B	
148mm Pistol Handle Shaft	OXPT10X148	OXPT10X148	
225mm Pistol Handle Shaft	OXPT10X225	OXPT10X225	
500mm Pistol Handle Shaft	OXPT10X500	OXPT10X500	

⁽¹⁾Consult ABB for availability.



IP54

IP54 Protection for extended rotary handle⁽¹⁾

Type	Part number		
IP54 Protection for RHE	KXTAERHEIP54		

⁽¹⁾IEC rated only.

Flange handle⁽¹⁾

Type	Part number		
Flange Handle + Mechanism + 4ft Cable (NEMA 1, 3R, 12, 4)	KXT4N12FLHDL4		
Flange Handle + Mechanism + 6ft Cable (NEMA 1, 3R, 12, 4)	KXT4N12FLHDL6		
Flange Handle + Mechanism + 10ft Cable (NEMA 1, 3R, 12, 4)	KXT4N12FLHDL10		
Flange Handle + Mechanism + 4ft Cable (NEMA 1, 3R, 12, 4, 4X)	KXT4N4XFLHDL4		
Flange Handle + Mechanism + 6ft Cable (NEMA 1, 3R, 12, 4, 4X)	KXT4N4XFLHDL6		
Flange Handle + Mechanism + 10ft Cable (NEMA 1, 3R, 12, 4, 4X)	KXT4N4XFLHDL10		

Flange Handle Spare Parts

Flange Handle only (NEMA 1, 3R, 12, 4)	KXTAN12FLHDL		
Flange Handle only (NEMA 1, 3R, 12, 4, 4X)	KXTAN4XFLHDL		
Flange Handle Hardware	KXTAFLHDLHW		
Flange Mounting Hardware	KXTCFLMTHW		

⁽¹⁾Consult ABB for availability.

Locks



Fixed padlock



Key lock on the circuit breaker



Key lock on the handle



Key lock on the motor



Front for operating lever mechanism



Interlock

Padlock on the circuit breaker

Type	Part number
PLL Fixed lock with padlocks in open position	KXTCPLLOP
PLL Fixed lock with padlocks in open/closed position	KXTCPLLOPCL

Key lock on the circuit breaker

Type	Part number
KLC Ronis key lock open, different keys, removable in open position	KXTCKLCCBDIF
KLC Ronis key lock open, same Type A keys, removable in open position	KXTCKLCCBA
KLC Ronis key lock open, same Type B keys, removable in open position	KXTCKLCCBB
KLC Ronis key lock open, same Type C keys, removable in open position	KXTCKLCCBC
KLC Ronis key lock open, same Type D keys, removable in open position	KXTCKLCCBD
KLC Ronis key lock open/closed, different keys, removable in both positions	KXTCKLCCBOPCL

Key lock on the rotary handle / key lock on the front for locks

Type	Part number
RHL Ronis key lock open, different keys, RHx/FLD	KXTARHLDIF
RHL Ronis key lock open, same Type A keys, RHx/FLD	KXTARHLA
RHL Ronis key lock open, same Type B keys, RHx/FLD	KXTARHLB
RHL Ronis key lock open, same Type C keys, RHx/FLD	KXTARHLC
RHL Ronis key lock open, same Type D keys, RHx/FLD	KXTARHLD
RHL Ronis key lock open/closed, different keys, RHx	KXTARHLOPCL
RHL Ronis key lock open/closed, different keys, FLD	KXTCRHLFLD

Key lock on the motor⁽¹⁾

Type	Part number
MOL-D Ronis key lock, open, different keys	KXTCCEMOLDIF
MOL-D Ronis key lock open, same Type A keys	KXTCCEMOLA
MOL-D Ronis key lock open, same Type B keys	KXTCCEMOLB
MOL-D Ronis key lock open, same Type C keys	KXTCCEMOLC
MOL-D Ronis key lock open, same Type D keys	KXTCCEMOLD
MOL-M Key lock against manual operation	KXTCCEMOLMO

⁽¹⁾IEC rated only

Front for operating lever mechanism

Type	Fixed/Plug-in Part number	Withdrawable Part number
FLD Front for operating lever mechanism	KXTCFLDFP	KXTCFLDW

Mechanical interlock

Type	Part number
Chassis MIR-H	KXTAMIRHR
Chassis MIR-V	KXTAMIRVR
Plate XT1 F	KXT1MIRPLF
Plate XT1 P	KXT1MIRPLP
Plate XT2 F	KXT2MIRPLF
Plate XT2 P/W	KXT2MIRPLPW
Plate XT4 F	KXT4MIRPLF
Plate XT4 P/W	KXT4MIRPLPW

Ordering codes for XT4 UL/CSA Accessories



RC Sel

Residual current devices⁽¹⁾

Residual current devices

Type	3p Part number	4p Part number
RC Sel	-	KXT4ERCSEL-4

⁽¹⁾IEC rated only.

Panel type residual current relay⁽¹⁾

Type	Part number
RCQ020/A 115-230V AC	KXTAERCQ230
RCQ020/A 415V AC	KXTAERCQ415
Toroid closed Ø 60mm	KXTTETOR60
Toroid closed Ø 110mm	KXTTETOR110
Toroid closed Ø 185mm	KXTTETOR185

⁽¹⁾IEC rated only.

7



DIN guide

Installation

Bracket for DIN rail mounting

Type	3p Part number	4p Part number
KIT DIN50022 ⁽¹⁾	KXTCEDINPL	KXTCEDINPL
KIT DIN50022 UL	KXT4DIN-3	KXT4DIN-4

⁽¹⁾IEC rated only.



Terminal covers

Terminals, terminal covers and phase barriers

Insulating terminal covers

Type	3p Part number	4p Part number
LTC low terminal covers	KXT4LTC-3	KXT4LTC-4
HTC high terminal covers	KXT4HTC-3	KXT4HTC-4



Sealable screw

Sealable screws for terminal covers⁽¹⁾

Type	Part number
Kit with two sealable screws	KXTAESSEAL

⁽¹⁾IEC rated only.



Phase barriers



EF terminal



FCCuAI terminal

Phase barriers

Type	4 pcs Part number	6 pcs Part number
PB height 25mm/0.98in	KXTCPB25-3	KXTCPB25-4
PB height 100mm/3.94in	KXTCPB100-3	KXTCPB100-4
PB height 200mm/7.87in	KXTCPB200-3	KXTCPB200-4

Terminals

Type	3 pcs Part number	4 pcs Part number	6 pcs Part number	8 pcs Part number
F Front terminals	KXT4F-3PC	KXT4F-4PC	KXT4F-6PC	KXT4F-8PC
EF Extended front terminals	KXT4EF-3PC	KXT4EF-4PC	KXT4EF-6PC	KXT4EF-8PC
ES Extended spread terminals	KXT4ES-3PC	KXT4ES-4PC	KXT4ES-6PC	KXT4ES-8PC
FC CuAI Terminals for CuAI cables 100A, 14-1/0 AWG, 1x2.5...50mm ²⁽¹⁾	KXT4CUAL1-3PC	KXT4CUAL1-4PC	KXT4CUAL1-6PC	KXT4CUAL1-8PC
FC CuAI Terminals for CuAI cables w/Control Tap 100A, 14-1/0 AWG, 1x2.5...50mm ²⁽¹⁾⁽²⁾	KXT4CUAL1C-3PC	KXT4CUAL1C-4PC	-	-
FC CuAI Terminals for CuAI cables 225A, 4 AWG -300 kcmil, 1x35...150mm ²⁽¹⁾	KXT4CUAL2-3PC	KXT4CUAL2-4PC	KXT4CUAL2-6PC	KXT4CUAL2-8PC
FC CuAI Terminals for CuAI cables w/Control Tap 225A, 4 AWG -300 kcmil, 1x35...150mm ²⁽¹⁾⁽²⁾	KXT4CUAL2C-3PC	KXT4CUAL2C-4PC	-	-
FC CuAI Terminals for CuAI cables 250A, 250-350 kcmil, 1x120...185mm ²⁽¹⁾⁽²⁾	KXT4CUAL3-3PC	KXT4CUAL3-4PC	KXT4CUAL3-6PC	KXT4CUAL3-8PC
FC Cu Terminals for Cu cables 250A, 10-250 AWG, 1x6...185mm ²	KXT4CU-3PC	KXT4CU-4PC	KXT4CU-6PC	KXT4CU-8PC
FC Cu Terminals for Cu cables, XT4X to 150A, 14-1/0 AWG, 1x2.5...50mm ²⁽³⁾	KXT4XCU-3PC	KXT4XCU-4PC	-	-
MC Multi cable terminals for Cu cables, 6x12-2 AWG, 6x2.5...35mm ²	KXT4MC-3PC	KXT4MC-4PC	KXT4MC-6PC	KXT4MC-8PC
R Rear adjustable terminals ⁽⁴⁾	KXT4ER-3PC	KXT4ER-4PC	KXT4ER-6PC	KXT4ER-8PC
FB Flexibar terminals ⁽⁴⁾	KXT4EFB-3PC	KXT4EFB-4PC	KXT4EFB-6PC	KXT4EFB-8PC

⁽¹⁾Not available for XT4 X up to 150A.

⁽²⁾Consult ABB for availability.

⁽³⁾For use with the XT4 X version up to 150A only. Note: XT4X from 175-250A uses the standard 250A CU lug.

⁽⁴⁾IEC rated only.

Ordering codes for XT4 UL/CSA Accessories



Ekip Display



Ekip LED Meter

Accessories for electronic trip units

General electronic trip unit accessories⁽¹⁾

Type	Fixed/Plug-in Part number	Withdrawable Part number		
Ekip Display	KXTCEDISP	KXTCEDISP		
Ekip LED Meter	KXTCELED	KXTCELED		
Ekip Com	KXTCECOMFP	KXTCECOMW		
HMI030 Interface on front of panel	HMI030	HMI030		
PR212/CI contactor control unit	1SDA050708R1	1SDA050708R1		

⁽¹⁾IEC rated only.

Current sensor for external neutral⁽¹⁾

Type	Part number			
CT external neutral of 40A	KXT4ECT40			
CT external neutral of 63A	KXT4ECT63			
CT external neutral of 100A	KXT4ECT100			
CT external neutral of 160A	KXT4ECT160			
CT external neutral of 250A	KXT4ECT250			

⁽¹⁾IEC rated only.

Connection kits

Type	Fixed/Plug-in Part number	Withdrawable Part number		
24V DC auxiliary voltage kit for electronic trip units ⁽¹⁾	KXTCECAUXFP	KXTCECAUXW		
External neutral connection kit	KXTCECNEFP	KXTCECNEW		

⁽¹⁾IEC rated only.



Ekip T&P unit

Test and configurator units⁽¹⁾

Type	Part number			
Ekip TT - Trip test unit	ZAEKPTT			
Ekip T&P - Programming and test unit	EKIP			

⁽¹⁾IEC rated only.

Automatic transfer devices

ATS021 - ATS022 Automatic transfer devices⁽¹⁾

Type	Part number			
ATS021	ATS021			
ATS022	ATS022			

⁽¹⁾IEC rated only.



ATS021

Spare parts

Type	Fixed/Plug-in Part number	Withdrawable Part number		
SA RC Sel - Opening solenoid for the residual current device ⁽¹⁾	KXT4ESARCFP	KXT4ESARCW		
AUX-C - Loose cabled auxiliary contact 250V AC ⁽²⁾	KXTAAUXCFP	KXTCEAUXCW		
AUX-C - Loose cabled auxiliary contact 24V DC ⁽²⁾	KXTAAUXCDFP	KXTCEAUXCDW		
AUX-C - Loose cabled auxiliary contact 250V AC HD	KXTAAUXCFPHD	KXTCAUXCWDW		
AUX-C - Loose cabled auxiliary contact 24V DC HD	KXTAAUXCDFPHD	KXTCAUXCDWHD		

⁽¹⁾IEC rated only.

⁽²⁾Un-numbered cables. Withdrawable versions are IEC rated only.



Fixed/Moving part connector for withdrawable

Connectors for fixed part/moving part of withdrawable circuit breakers⁽¹⁾

Type	Part number			
1 connector for with 2 pins for SOR/UVR up to 400V	KXTCE2PINCONSOUV			
1 connector with 3 pins for AUX up to 400V	KXTCE3PINCONAUX			

⁽¹⁾IEC rated only.



Flange

Flanges for the compartment door⁽¹⁾

Type	3p Fixed/Plug-in Part number	4p Fixed/Plug-in Part number	3p Withdrawable Part number	4p Withdrawable Part number
Small "optional" flange for circuit breaker	KXTAEFLASMFP	KXTAEFLASMFP	-	-
Large "standard" flange for circuit breaker	KXT4EFLAFP-3	KXT4EFLAFP-4	-	-
Flange for MOE/MOE-E/FLD	KXTCEFLAMOEFP	KXTCEFLAMOEFP	KXTCEFLAMOEW	KXTCEFLAMOEW
Flange for direct handle RHD	KXTAEFLARHDFP	KXTAEFLARHDFP	KXTCEFLARHDW	KXTCEFLARHDW
Flange for residual current RC Sel	-	KXT4EFLARCFP-4	-	KXT4EFLARCW-4

⁽¹⁾IEC rated only.

Contact us

ABB

Low Voltage Products
8155 T&B Boulevard
Memphis, TN 38125
www.abb.com/lowvoltage

USA Technical Support: 888-385-1221
Customer Service: 888-862-3290
7:00 AM to 5:30 PM, CST, Monday – Friday
lvps.support@us.abb.com

The data and illustrations are not binding. We reserve the right to make changes in the course of technical development of the product.

© Copyright 2015 ABB.
All rights reserved.

1SXU200095C0201 – May 2015