

ATV930U30N4

Variable speed drive, Altivar Process ATV900,
ATV930, 3 kW, 400/480 V, with braking unit, IP21



Main

Device application	Industrial application
Device short name	ATV930
Product destination	Asynchronous motors Synchronous motors
EMC filter	Integrated with 50 m conforming to EN/IEC 61800-3 category C2 Integrated with 150 m conforming to EN/IEC 61800-3 category C3
IP degree of protection	IP21 conforming to IEC 61800-5-1 IP21 conforming to IEC 60529
Degree of protection	UL type 1 conforming to UL 508C
Type of cooling	Forced convection
Supply frequency	50...60 Hz +/- 5 %
Network number of phases	3 phases
Motor power kW	3 kW (normal duty) 2.2 kW (heavy duty)
Motor power hp	3 hp heavy duty
Line current	5.8 A at 380 V (normal duty) 5.1 A at 480 V (normal duty) 4.5 A at 380 V (heavy duty) 4 A at 480 V (heavy duty)
Continuous output current	7.2 A at 4 kHz for normal duty 5.6 A at 4 kHz for heavy duty
Maximum transient current	8.6 A during 60 s (normal duty) 8.4 A during 60 s (heavy duty)
Speed drive output frequency	0.1...599 Hz
Safety function	STO (safe torque off) SIL 3
Option module	Slot A: communication module for Profibus DP V1 Slot A: communication module for Profinet Slot A: communication module for DeviceNet Slot A: communication module for EtherCAT Slot A: communication module for CANopen daisy chain RJ45 Slot A: communication module for CANopen SUB-D 9

Disclaimer: This documentation is not intended as a substitute for and is not to be used for determining suitability or reliability of these products for specific user applications

Slot A: communication module for CANopen screw terminals
 Slot A/slot B/slot C: digital and analog I/O extension module
 Slot A/slot B/slot C: output relay extension module
 Slot B: 5/12 V digital encoder interface module
 Slot B: analog encoder interface module
 Slot B: resolver encoder interface module
 communication module for Ethernet Powerlink

Range of product	Altivar Process ATV900
Product or component type	Variable speed drive
Variant	With braking chopper Standard version
Mounting mode	Wall mount
Communication port protocol	Modbus serial EtherNet/IP Modbus TCP
[Us] rated supply voltage	380...480 V - 15...10 %
IP degree of protection	IP21

Complementary

Output voltage	<= power supply voltage
Frequency resolution	Display unit: 0.1 Hz Analog input: 0.012/50 Hz
Electrical connection	Control: screw terminal 0.5...1.5 mm ² /AWG 20...AWG 16 Line side: screw terminal 2.5...6 mm ² /AWG 14...AWG 10 Motor: screw terminal 2.5...6 mm ² /AWG 14...AWG 10 DC bus: screw terminal 2.5...6 mm ² /AWG 14...AWG 10
Connector type	2 RJ45 for Ethernet IP/Modbus TCP on the control block 1 RJ45 for Modbus serial on the control block
Physical interface	2-wire RS 485 for Modbus serial
Transmission frame	RTU for Modbus serial
Transmission rate	10/100 Mbit/s for Ethernet IP/Modbus TCP 4.8, 9.6, 19.2, 38.4 kbit/s for Modbus serial
Exchange mode	Half duplex, full duplex, autonegotiation Ethernet IP/Modbus TCP
Data format	8 bits, configurable odd, even or no parity for Modbus serial
Type of polarization	No impedance for Modbus serial
Number of addresses	1...247 for Modbus serial
Supply	External supply for digital inputs: 24 V DC (19...30 V), <1.25 mA, protection type: overload and short-circuit protection Internal supply for reference potentiometer (1 to 10 kOhm): 10.5 V DC +/- 5 %, <10 mA, protection type: overload and short-circuit protection Internal supply for digital inputs and STO: 24 V DC (21...27 V), <200 mA, protection type: overload and short-circuit protection
Local signalling	Local diagnostic: 3 LED (mono/dual colour) Embedded communication status: 5 LED (dual colour) Communication module status: 2 LED (dual colour) Presence of voltage: 1 LED (red)
Input compatibility	DI1...DI8: discrete input level 1 PLC conforming to EN/IEC 61131-2 DI7, DI8: pulse input level 1 PLC conforming to IEC 65A-68 STOA, STOB: discrete input level 1 PLC conforming to EN/IEC 61131-2
Discrete input logic	Positive logic (source) (DI1...DI8), < 5 V (state 0), > 11 V (state 1) Negative logic (sink) (DI1...DI8), > 16 V (state 0), < 10 V (state 1) Positive logic (source) (DI7, DI8), < 0.6 V (state 0), > 2.5 V (state 1) Positive logic (source) (STOA, STOB), < 5 V (state 0), > 11 V (state 1)
Sampling duration	2 ms +/- 0.5 ms (DI1...DI8) - discrete input 5 ms +/- 1 ms (DI7, DI8) - pulse input 1 ms +/- 1 ms (AI1, AI2, AI3) - analog input 5 ms +/- 1 ms (AQ1, AQ2) - analog output
Accuracy	+/- 0.6 % AI1, AI2, AI3 for a temperature variation 60 °C analog input +/- 1 % AQ1, AQ2 for a temperature variation 60 °C analog output
Linearity error	AI1, AI2, AI3: +/- 0.15 % of maximum value for analog input AQ1, AQ2: +/- 0.2 % for analog output
Refresh time	Relay output (R1, R2, R3): 5 ms (+/- 0.5 ms)
Isolation	Between power and control terminals

Variable speed drive application selection	Food and beverage processing Mixer Food and beverage processing Conveyor Food and beverage processing Shredder Hoisting Process crane Marine Thruster Marine Winch Material working (wood, ceramic, stone, pvc, metal) Press Material working (wood, ceramic, stone, pvc, metal) Extruder Mining mineral and metal Other application Oil and gas Drilling rig Oil and gas Progressive cavity pump Oil and gas Rod pump Oil and gas Swapping pump Oil and gas Compressor for regasification Oil and gas Separator Oil and gas Other application Water and waste water Separator
Power range	2.2...3 kW at 380...440 V 3 phases 2.2...3 kW at 480...500 V 3 phases
Discrete input number	10
Discrete input type	DI1...DI8 programmable, 24 V DC (≤ 30 V), impedance: 3.5 kOhm DI7, DI8 programmable as pulse input: 0...30 kHz, 24 V DC (≤ 30 V) STOA, STOB safe torque off, 24 V DC (≤ 30 V), impedance: > 2.2 kOhm
Number of preset speeds	16 preset speeds
Discrete output number	2
Discrete output type	Logic output DQ+ 0...1 kHz ≤ 30 V DC 100 mA Programmable as pulse output DQ+ 0...30 kHz ≤ 30 V DC 20 mA Logic output DQ- 0...1 kHz ≤ 30 V DC 100 mA
Analogue input number	3
Analogue input type	AI1, AI2, AI3 software-configurable voltage: 0...10 V DC, impedance: 30 kOhm, resolution 12 bits AI1, AI2, AI3 software-configurable current: 0...20 mA/4...20 mA, impedance: 250 Ohm, resolution 12 bits
Analogue output number	2
Analogue output type	Software-configurable voltage AQ1, AQ2: 0...10 V DC impedance 470 Ohm, resolution 10 bits Software-configurable current AQ1, AQ2: 0...20 mA impedance 500 Ohm, resolution 10 bits
Relay output number	3
Relay output type	Configurable relay logic R1: fault relay NO/NC electrical durability 100000 cycles Configurable relay logic R2: sequence relay NO electrical durability 1000000 cycles Configurable relay logic R3: sequence relay NO electrical durability 1000000 cycles
Maximum switching current	Relay output R1 on resistive load, $\cos \phi = 1$: 3 A at 250 V AC Relay output R1 on resistive load, $\cos \phi = 1$: 3 A at 30 V DC Relay output R1 on inductive load, $\cos \phi = 0.4$ and $L/R = 7$ ms: 2 A at 250 V AC Relay output R1 on inductive load, $\cos \phi = 0.4$ and $L/R = 7$ ms: 2 A at 30 V DC Relay output R2, R3 on resistive load, $\cos \phi = 1$: 5 A at 250 V AC Relay output R2, R3 on resistive load, $\cos \phi = 1$: 5 A at 30 V DC Relay output R2, R3 on inductive load, $\cos \phi = 0.4$ and $L/R = 7$ ms: 2 A at 250 V AC Relay output R2, R3 on inductive load, $\cos \phi = 0.4$ and $L/R = 7$ ms: 2 A at 30 V DC
Minimum switching current	Relay output R1, R2, R3: 5 mA at 24 V DC
Method of access	Slave Modbus TCP
Asynchronous motor control profile	Variable torque standard Constant torque standard Optimized torque mode
Synchronous motor control profile	Permanent magnet motor Synchronous reluctance motor
Acceleration and deceleration ramps	Linear adjustable separately from 0.01...9999 s
Motor slip compensation	Automatic whatever the load Not available in permanent magnet motor law Adjustable Can be suppressed
Switching frequency	2...16 kHz adjustable 4...16 kHz with derating factor
Nominal switching frequency	4 kHz
Braking to standstill	By DC injection
Apparent power	4.2 kVA at 480 V (normal duty) 3.3 kVA at 480 V (heavy duty)

Prospective line I _{sc}	50 kA
Power dissipation in W	Natural convection: 31 W at 380 V, switching frequency 4 kHz Forced convection: 78 W at 380 V, switching frequency 4 kHz
Protection type	Thermal protection: motor Safe torque off: motor Motor phase break: motor Thermal protection: drive Safe torque off: drive Overheating: drive Overcurrent between output phases and earth: drive Overload of output voltage: drive Short-circuit protection: drive Motor phase break: drive Overvoltages on the DC bus: drive Line supply overvoltage: drive Line supply undervoltage: drive Line supply phase loss: drive Overspeed: drive Break on the control circuit: drive
Width	144 mm
Height	350 mm
Depth	206 mm
Product weight	4.6 kg

Environment

Insulation resistance	> 1 MOhm 500 V DC for 1 minute to earth
Noise level	54.5 dB conforming to 86/188/EEC
Vibration resistance	1.5 mm peak to peak (f= 2...13 Hz) conforming to IEC 60068-2-6 1 gn (f= 13...200 Hz) conforming to IEC 60068-2-6
Shock resistance	15 gn for 11 ms conforming to IEC 60068-2-27
Environmental characteristic	Chemical pollution resistance class 3C3 conforming to EN/IEC 60721-3-3 Dust pollution resistance class 3S3 conforming to EN/IEC 60721-3-3
Pollution degree	2 conforming to EN/IEC 61800-5-1
Relative humidity	5...95 % without condensation conforming to IEC 60068-2-3
Ambient air temperature for operation	-15...50 °C (without derating) 50...60 °C (with derating factor)
Standards	UL 508C EN/IEC 61800-3 Environment 1 category C2 EN/IEC 61800-3 Environment 2 category C3 EN/IEC 61800-3 EN/IEC 61800-5-1 IEC 61000-3-12 IEC 60721-3 IEC 61508 IEC 13849-1
Operating altitude	<= 1000 m without derating 1000...4800 m with current derating 1 % per 100 m
Operating position	Vertical +/- 10 degree
Product certifications	TÜV CSA UL
Marking	CE
Maximum THDI	<48 % full load conforming to IEC 61000-3-12
Electromagnetic compatibility	Electrostatic discharge immunity test level 3 conforming to IEC 61000-4-2 Radiated radio-frequency electromagnetic field immunity test level 3 conforming to IEC 61000-4-3 Electrical fast transient/burst immunity test level 4 conforming to IEC 61000-4-4 1.2/50 µs - 8/20 µs surge immunity test level 3 conforming to IEC 61000-4-5 Conducted radio-frequency immunity test level 3 conforming to IEC 61000-4-6
Volume of cooling air	38 m ³ /h
Ambient air temperature for storage	-40...70 °C

Packing Units

Unit Type of Package 1	PCE
Number of Units in Package 1	1
Package 1 Weight	6.085 kg
Package 1 Height	31 cm
Package 1 width	19 cm
Package 1 Length	41 cm
Unit Type of Package 2	P06
Number of Units in Package 2	6
Package 2 Weight	49.51 kg
Package 2 Height	73.5 cm
Package 2 width	60 cm
Package 2 Length	80 cm

Offer Sustainability

Sustainable offer status	Green Premium product
REACH Regulation	REACH Declaration
EU RoHS Directive	Pro-active compliance (Product out of EU RoHS legal scope) EU RoHS Declaration
Mercury free	Yes
RoHS exemption information	Yes
China RoHS Regulation	China RoHS declaration
WEEE	The product must be disposed on European Union markets following specific waste collection and never end up in rubbish bins
California proposition 65	WARNING: This product can expose you to chemicals including: Lead and lead compounds, which is known to the State of California to cause cancer and birth defects or other reproductive harm. For more information go to www.P65Warnings.ca.gov
Upgradeability	Upgraded components available 

Dimensions

Right, Front and Rear View

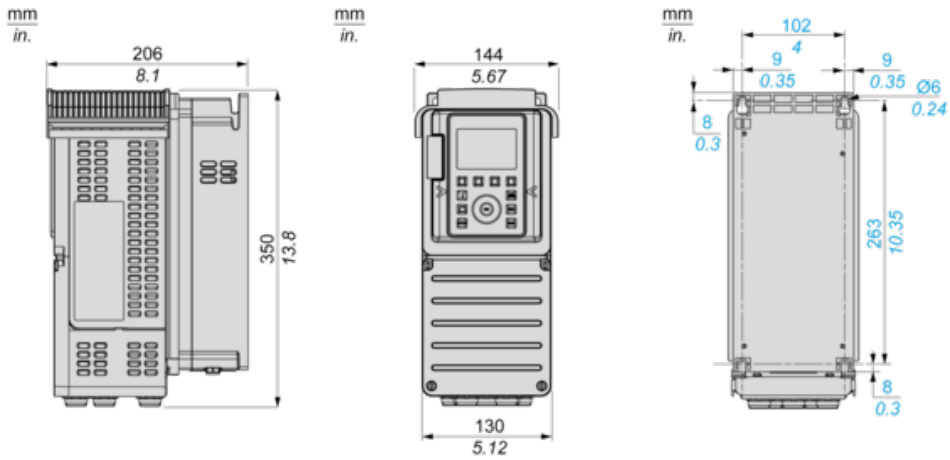

Clearances

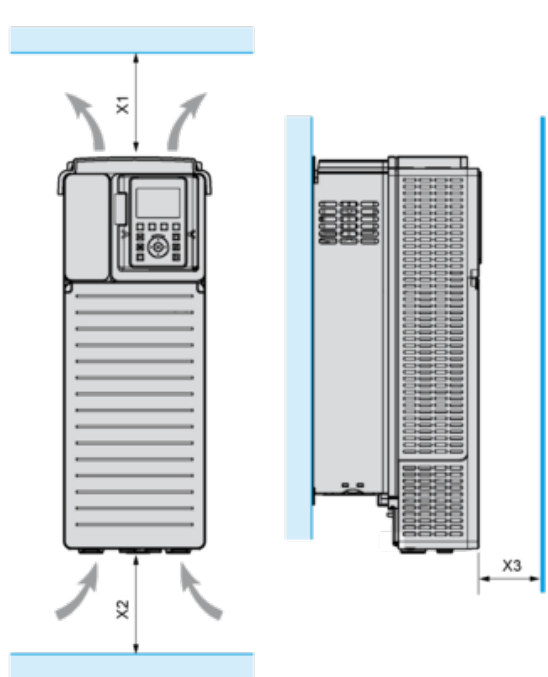

X1	X2	X3
≥ 100 mm (3.94 in.)	≥ 100 mm (3.94 in.)	≥ 10 mm (0.39 in.)

- Mount the device in a vertical position ($\pm 10^\circ$). This is required for cooling the device.
- Do not mount the device close to heat sources.
- Leave sufficient free space so that the air required for cooling purposes can circulate from the bottom to the top of the drive.

Mounting Types

Mounting Type A: Individual IP21

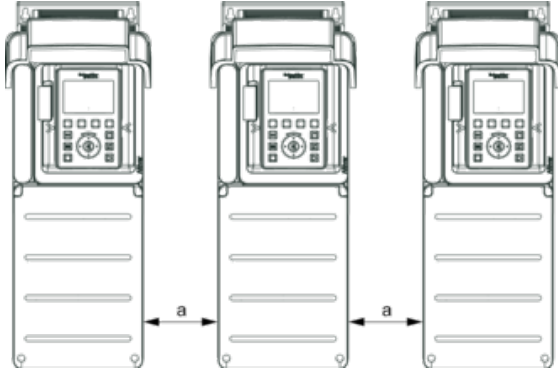

$a \geq 100 \text{ mm (3.94 in.)}$

Mounting Type B: Side by Side IP20

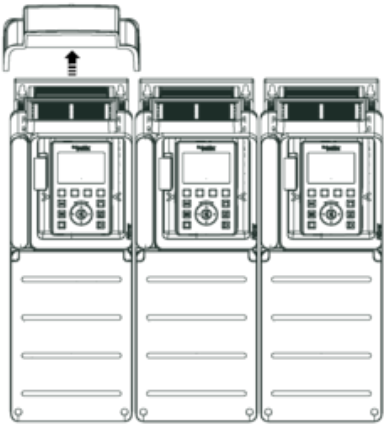

Mounting Type C: Individual IP20

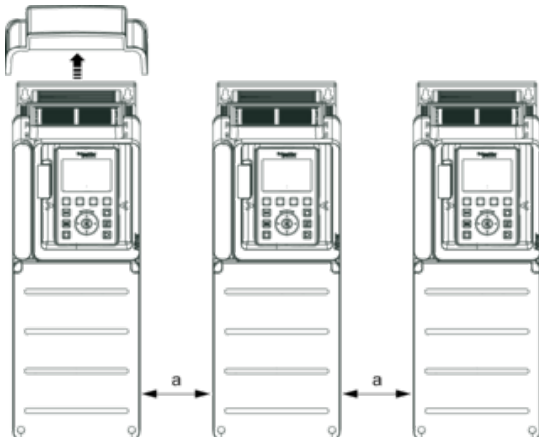

$a \geq 0$

Three-Phase Power Supply with Upstream Breaking via Line Contactor

Connection diagrams conforming to standards EN 954-1 category 1 and IEC/EN 61508 capacity SIL1, stopping category 0 in accordance with standard IEC/EN 60204-1

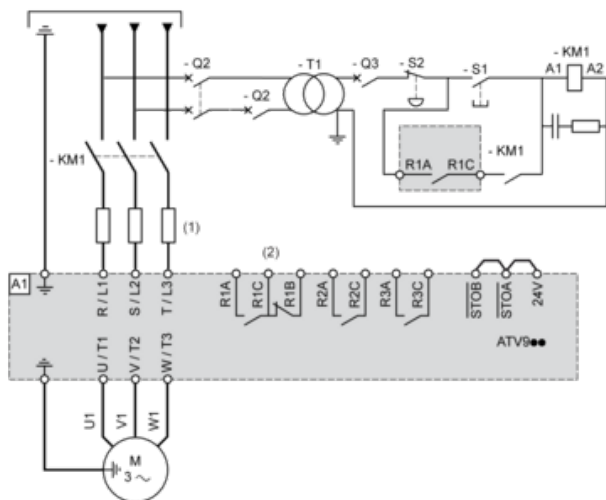

(1) Line choke if used

(2) Use relay R1 set to operating state Fault to switch Off the product once an error is detected.

A1 : Drive

KM1 : Line Contactor

Q2, Q3 : Circuit breakers

S1, S2 : Pushbuttons

T1 : Transformer for control part

Three-Phase Power Supply with Downstream Breaking via Contactor

Connection diagrams conforming to standards EN 954-1 category 1 and IEC/EN 61508 capacity SIL1, stopping category 0 in accordance with standard IEC/EN 60204-1

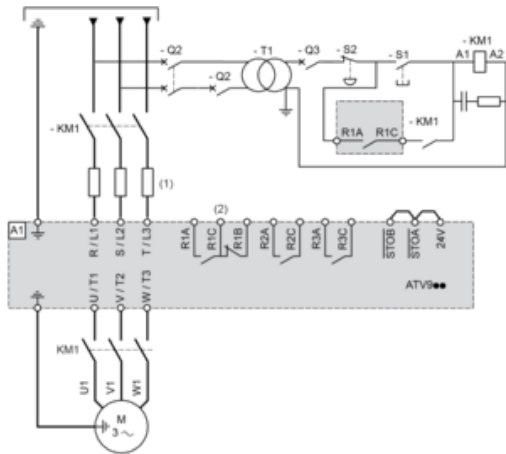

(1) Line choke if used

(2) Use relay R1 set to operating state Fault to switch Off the product once an error is detected.

A1 : Drive

KM1 : Contactor

Control Block Wiring Diagram

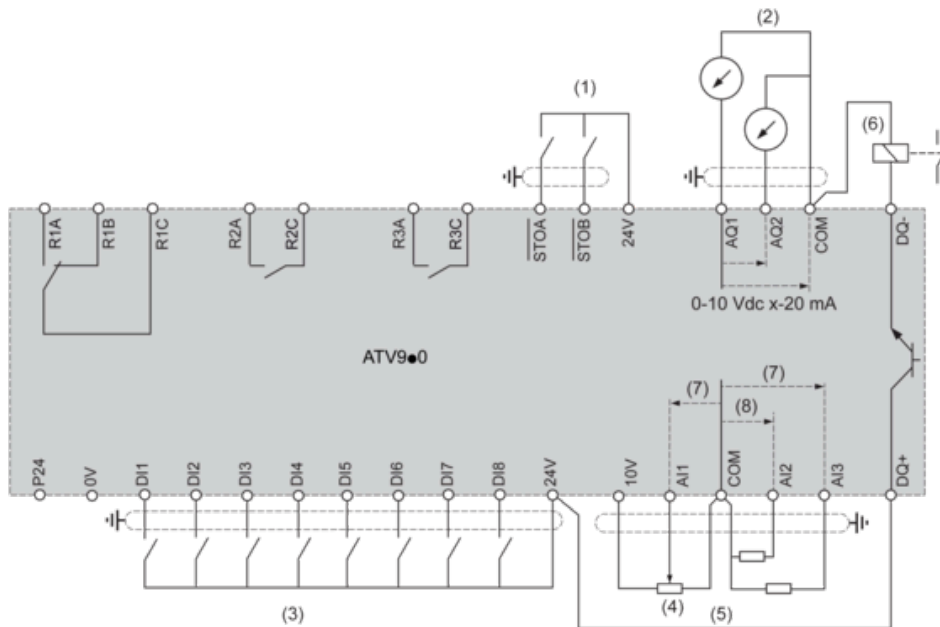

- (1) Safe Torque Off
 - (2) Analog Output
 - (3) Digital Input
 - (4) Reference potentiometer
 - (5) Analog Input
 - (6) Digital Output
 - (7) 0-10 Vdc, x-20 mA
 - (8) 0-10 Vdc, -10 Vdc...+10 Vdc
- R1A, R1B, R1C : Fault relay
R2A, R2C : Sequence relay
R3A, R3C : Sequence relay

Sensor Connection

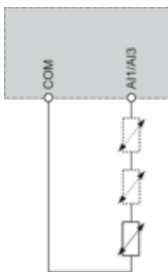

It is possible to connect either 1 or 3 sensors on terminals AI1 or AI3

Sink / Source Switch Configuration

The switch is used to adapt the operation of the logic inputs to the technology of the programmable controller outputs.

- Set the switch to Source (factory setting) if using PLC outputs with PNP transistors.
- Set the switch to Ext if using PLC outputs with NPN transistors.

Switch Set to SRC (Source) Position Using the Output Power Supply for the Digital Inputs

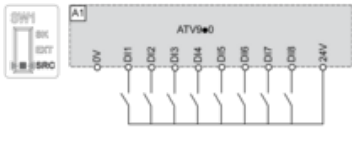

Switch Set to SRC (Source) Position and Use of an External Power Supply for the DIs

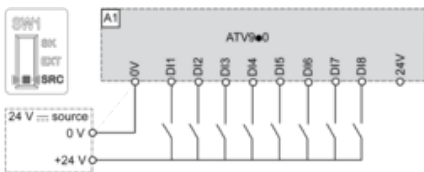

Switch Set to SK (Sink) Position Using the Output Power Supply for the Digital Inputs

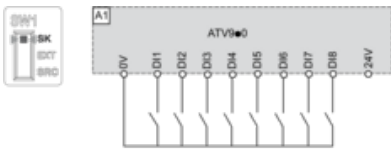

Switch Set to EXT Position Using an External Power Supply for the DIs

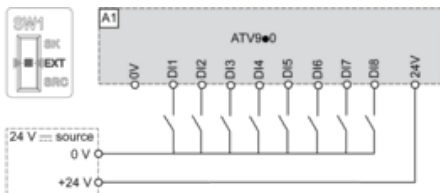

Derating Curves

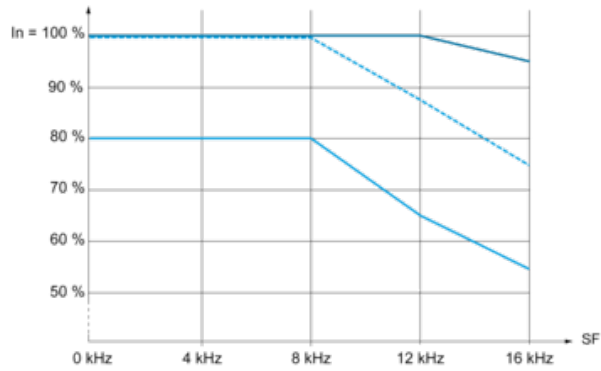

- 40 °C (104 °F) - Mounting type A, B and C
- - - 50 °C (122 °F) - Mounting type A, B and C
- 60 °C (140 °F) - Mounting type B and C

In : Nominal Drive Current

SF : Switching Frequency