

# ATV610C13N4

variable speed drive ATV610 - 132 kW / 200HP  
- 380...415 V - IP20



## Main

Range of product	Altivar Easy 610
Product or component type	Variable speed drive
Product specific application	Fan, pump, compressor, conveyor
Device short name	ATV610
Variant	Standard version
Product destination	Asynchronous motors
Mounting mode	Cabinet mount
EMC filter	Integrated conforming to EN/IEC 61800-3 category C3 with 50 m maximum
IP degree of protection	IP20
Type of cooling	Forced convection
Supply frequency	50...60 Hz (+/-5 %)
Network number of phases	3 phases
[Us] rated supply voltage	380...415 V (- 15...10 %)
Motor power kW	132 kW normal duty 110 kW heavy duty
Motor power hp	200 hp normal duty 150 hp heavy duty
Line current	237 A at 380 V normal duty 213 A at 415 V normal duty 201 A at 380 V heavy duty 188 A at 415 V heavy duty
Prospective line I <sub>sc</sub>	50 kA
Apparent power	153.1 kVA at 415 V normal duty 135.1 kVA at 415 V heavy duty
Continuous output current	250 A at 2.5 kHz normal duty 211 A at 2.5 kHz heavy duty
Maximum transient current	275 A during 60 s normal duty 317 A during 60 s heavy duty
Asynchronous motor control profile	Optimized torque mode Constant torque standard Variable torque standard
Output frequency	0.0001...0.5 kHz
Nominal switching frequency	2.5 kHz
Switching frequency	1...8 kHz adjustable
Discrete input logic	16 preset speeds
Communication port protocol	Modbus serial
Option card	Slot A : communication card Profibus DP V1 Slot A : digital or analog I/O extension card Slot A : relay output card

The information provided in this documentation contains general descriptions and/or technical characteristics of the performance of the products contained herein. This documentation is not intended as a substitute for and is not to be used for determining suitability or reliability of these products for specific user applications. It is the duty of any such user or integrator to perform the appropriate and complete risk analysis, evaluation and testing of the products with respect to the relevant specific application or use thereof. Neither Schneider Electric Industries SAS nor any of its affiliates or subsidiaries shall be responsible or liable for misuse of the information contained herein.

## Complementary

Output voltage	$\leq$ power supply voltage
Motor slip compensation	Not available in permanent magnet motor law Adjustable Automatic whatever the load Can be suppressed
Acceleration and deceleration ramps	Linear adjustable separately from 0.01 to 9000 s S, U or customized
Braking to standstill	By DC injection
Protection type	Motor : thermal protection Motor : motor phase break Drive : thermal protection Drive : overheating Drive : overcurrent between output phases and earth Drive : overload of output voltage Drive : short-circuit protection Drive : motor phase break Drive : overvoltages on the DC bus Drive : line supply overvoltage Drive : line supply undervoltage Drive : line supply phase loss Drive : overspeed Drive : break on the control circuit
Frequency resolution	Display unit : 0.1 Hz Analog input : 0.012/50 Hz
Electrical connection	Control, screw terminal : 0.5...1.5 mm <sup>2</sup> Line side, screw terminal : 2 x 70...3 x 120 mm <sup>2</sup> Motor, screw terminal : 3 x 70...3 x 120 mm <sup>2</sup>
Connector type	1 RJ45 (on the remote graphic terminal) for Modbus serial
Physical interface	2-wire RS 485 for Modbus serial
Transmission frame	RTU for Modbus serial
Transmission rate	4.8, 9.6, 19.2, 38.4 kbit/s for Modbus serial
Type of polarization	No impedance for Modbus serial
Number of addresses	1...247 for Modbus serial
Method of access	Slave
Supply	External supply for digital inputs : 24 V DC (limits : 19...30 V), $\leq$ 1.25 mA (overload and short-circuit protection) Internal supply for reference potentiometer (1 to 10 kOhm) : 10.5 V DC +/- 5 %, $\leq$ 10 mA (overload and short-circuit protection)
Local signalling	1 LED red for presence of voltage 2 LEDs for local diagnostic 1 LED yellow for embedded communication status 2 LEDs dual colour for communication module status
Width	320 mm
Height	852 mm 1159 mm with IP21 conformity kit
Depth	390 mm
Product weight	82 kg
Analogue input number	3
Analogue input type	Software-configurable voltage AI1, AI2, AI3 : 0...10 V DC, impedance 30 kOhm, resolution 12 bits Software-configurable current AI1, AI2, AI3 : 0...20 mA, impedance 250 Ohm, resolution 12 bits Software-configurable temperature probe or water level sensor AI2, AI3
Discrete input number	6
Discrete input type	Programmable as pulse input DI5, DI6 0...30 kHz : 24 V DC (limits : $\leq$ 30 V) Programmable as logic input DI1...DI6 : 24 V DC (limits : $\leq$ 30 V), impedance 3.5 kOhm
Input compatibility	Level 1 PLC conforming to EN/IEC 61131-2, logic input DI1...DI6 Level 1 PLC conforming to IEC 65A-68, pulse input DI5, DI6
Discrete input logic	Positive logic (source) : DI1...DI6 configurable logic input, $<$ 5 V (state 0), $>$ 11 V (state 1) Negative logic (sink) : DI1...DI6 configurable logic input, $>$ 16 V (state 0), $<$ 10 V (state 1) Positive logic (source) : DI5, DI6 configurable pulse input, $<$ 0.6 V (state 0), $>$ 2.5 V (state 1)
Analogue output number	2

Analogue output type	Software-configurable voltage AQ1, AQ2 : 0...10 V DC, impedance > 470 Ohm, resolution 10 bits Software-configurable current AQ1, AQ2 : 0...20 mA, resolution 10 bits
Sampling duration	Analog input AI1, AI2, AI3 : 5 ms (+/- 0.1 ms) Analog output AQ1, AQ2 : 10 ms (+/- 1 ms) Discrete input DI1...DI6 : 2 ms (+/- 0.5 ms) configurable Pulse input DI5, DI6 : 5 ms (+/- 1 ms) configurable
Accuracy	Analog input AI1, AI2, AI3 : +/- 0.6 % for a temperature variation 60 °C Analog output AQ1, AQ2 : +/- 1 % for a temperature variation 60 °C
Linearity error	Analog input AI1, AI2, AI3 : +/- 0.15 % of maximum value Analog output AQ1, AQ2 : +/- 0.2 %
Relay output number	3
Relay output type	Configurable relay logic R1 : fault relay NO/NC, electrical durability 100000 cycles Configurable relay logic R2 : sequence relay NO, electrical durability 100000 cycles Configurable relay logic R3 : sequence relay NO, electrical durability 100000 cycles
Refresh time	Relay output R1, R2, R3 : 5 ms (+/- 0.5 ms)
Minimum switching current	Relay output R1, R2, R3 : 5 mA at 24 V DC
Maximum switching current	Relay output R1, R2, R3 on resistive load (cos phi = 1) : 3 A at 250 V AC Relay output R1, R2, R3 on resistive load (cos phi = 1) : 3 A at 30 V DC Relay output R1, R2, R3 on inductive load (cos phi = 0.4 and L/R = 7 ms) : 2 A at 250 V AC Relay output R1, R2, R3 on inductive load (cos phi = 0.4 and L/R = 7 ms) : 2 A at 30 V DC
Isolation	Between power and control terminals
Insulation resistance	> 1 mOhm at 500 V DC for 1 minute to earth

## Environment

Noise level	76 dB conforming to 86/188/EEC
Power dissipation in W	2755 W (forced convection) at 380 V, switching frequency 2.5 kHz
Operating position	Vertical +/- 10 degree
Electromagnetic compatibility	1.2/50 µs - 8/20 µs surge immunity test level 3 conforming to IEC 61000-4-5 Electrical fast transient/burst immunity test level 4 conforming to IEC 61000-4-4 Electrostatic discharge immunity test level 3 conforming to IEC 61000-4-2 Radiated radio-frequency electromagnetic field immunity test level 3 conforming to IEC 61000-4-3 Conducted radio-frequency immunity test level 3 conforming to IEC 61000-4-6
Pollution degree	2 conforming to EN/IEC 61800-5-1
Vibration resistance	1.5 mm peak to peak (f= 2...13 Hz) conforming to IEC 60068-2-6 1 gn (f= 13...200 Hz) conforming to IEC 60068-2-6
Shock resistance	6 gn during 11 ms conforming to IEC 60068-2-27
Relative humidity	5...95 % without condensation conforming to IEC 60068-2-3
Ambient air temperature for operation	-15...45 °C without derating 45...60 °C with derating factor
Operating altitude	1000...4800 m with current derating 1 % per 100 m <= 1000 m without derating
Environmental characteristic	Chemical pollution resistance class 3C3 conforming to EN/IEC 60721-3-3 Dust pollution resistance class 3S3 conforming to EN/IEC 60721-3-3
Standards	EN/IEC 61800-3 EN/IEC 61800-3 environment 2 category C3 EN/IEC 61800-5-1 IEC 60721-3
Product certifications	REACH
Marking	CE

## Offer Sustainability

Sustainable offer status	Green Premium product
RoHS (date code: YYWW)	Compliant - since 1505 - Schneider Electric declaration of conformity <a href="#">Schneider Electric declaration of conformity</a>
REACH	Reference not containing SVHC above the threshold
Product environmental profile	Available <a href="#">Product Environmental</a>
Product end of life instructions	Available <a href="#">Product Environmental</a>

Dimensions

IP20 Drives

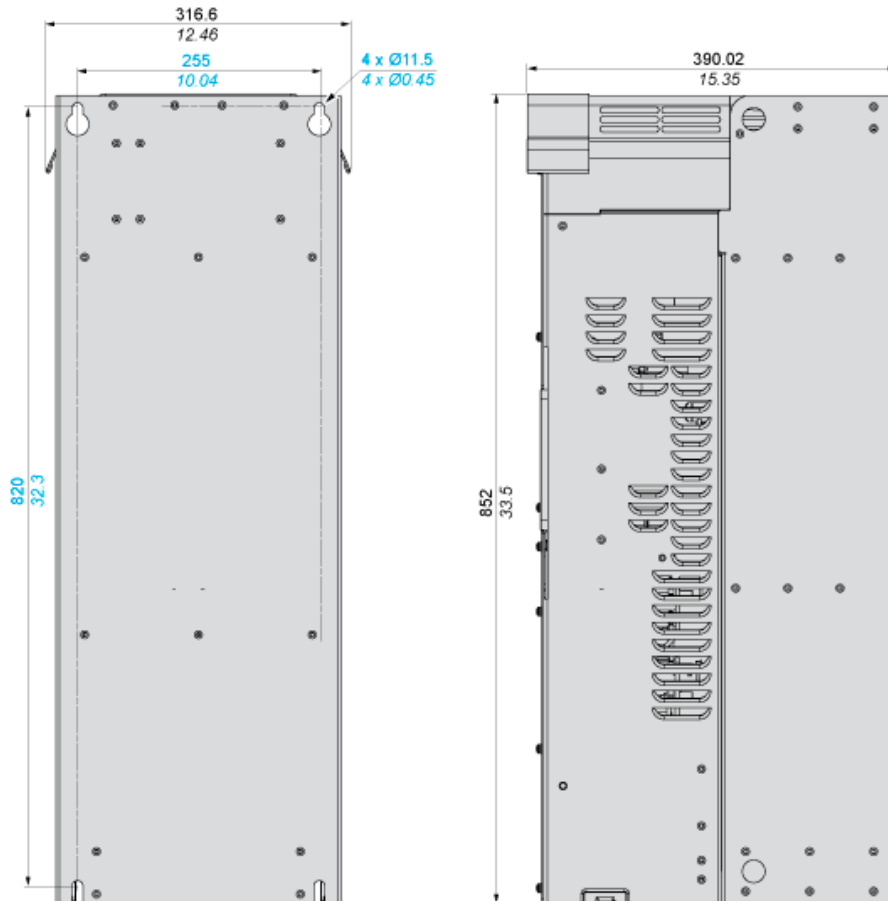

Drawings from left to right: rear view, right side view with top cover.

IP21 Drives with Lower Conduit Box Sold Separately

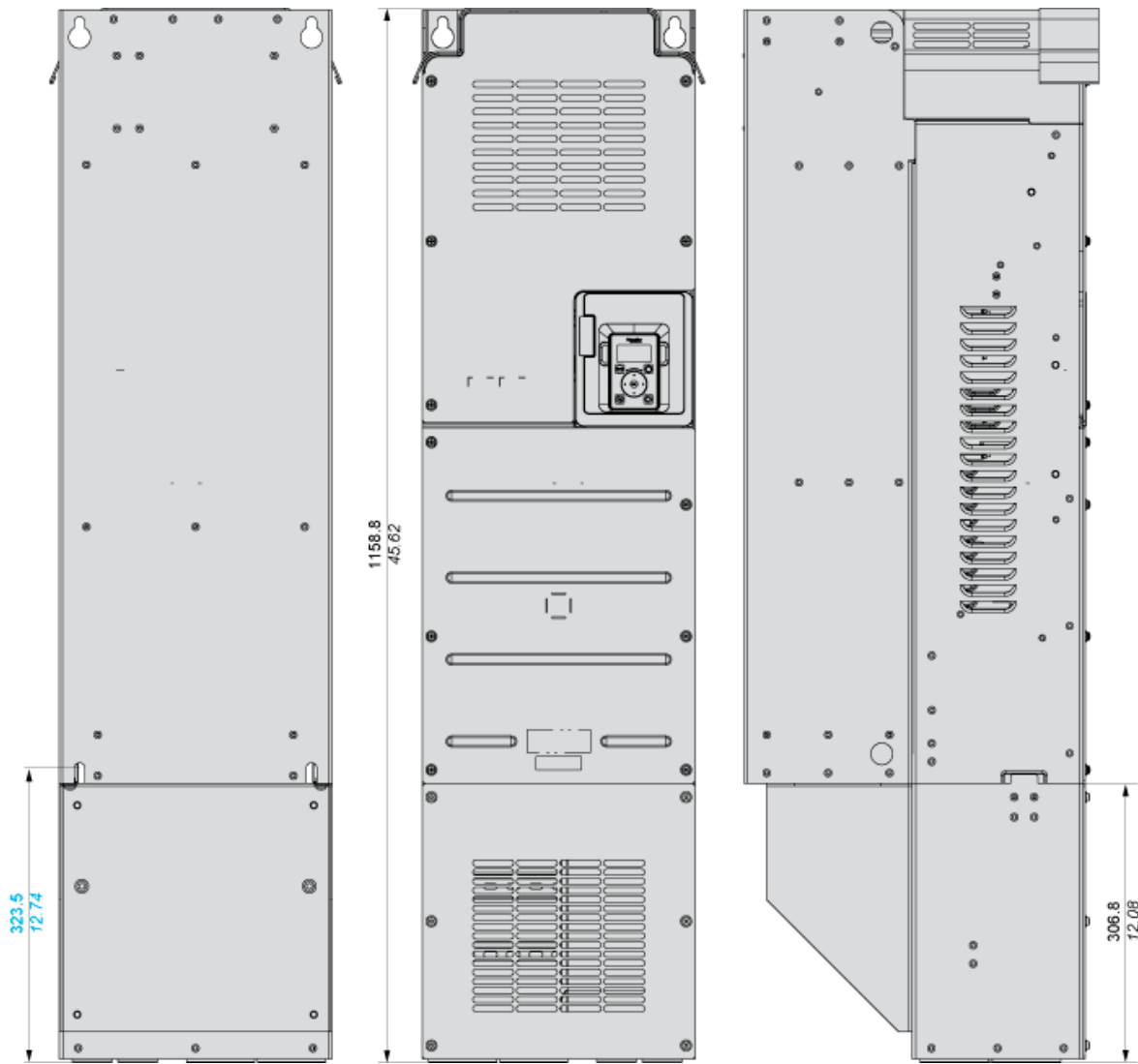

Drawings from left to right: rear view, front view and left side view with top cover.

Clearances

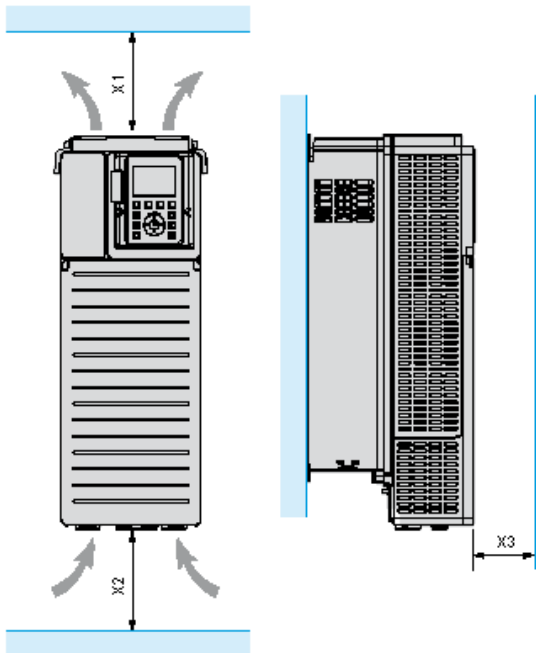

X1	X2	X3
≥ 250 mm (10 in.)	≥ 250 mm (10 in.)	≥ 100 mm (3.94 in.)

- Mount the device in a vertical position ( $\pm 10^\circ$ ). This is required for cooling the device.
- Do not mount the device close to heat sources.
- Leave sufficient free space so that the air required for cooling purposes can circulate from the bottom to the top of the drive.

Mounting Types

Mounting Type A: Individual IP21

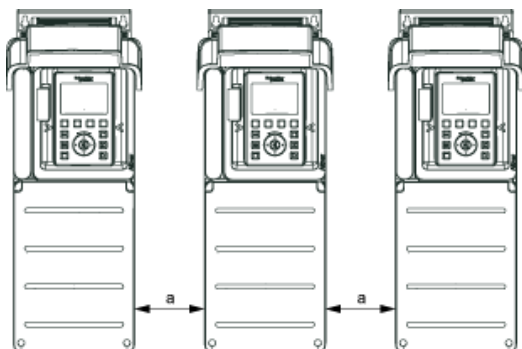

$a \geq 110 \text{ mm (4.33 in.)}$

Mounting Type B: Side by Side IP20 , Only possible at ambient temperature lower than 40 °C (104 °F)

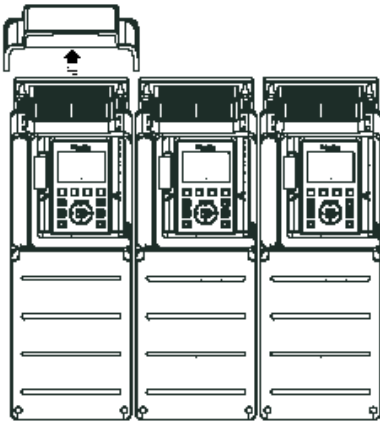

Mounting Type C: Individual IP20

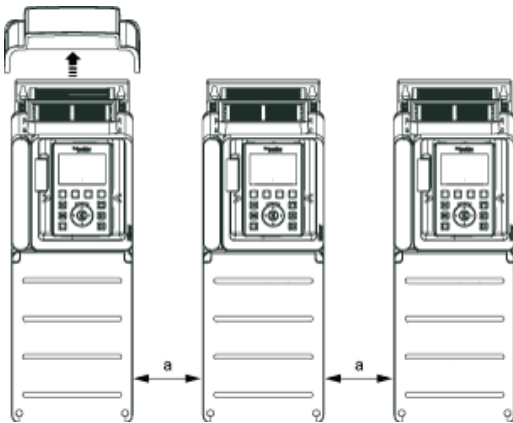

$a \geq 110 \text{ mm (4.33 in.)}$

## Single or Three-phase Power Supply - Diagram With Line Contactor

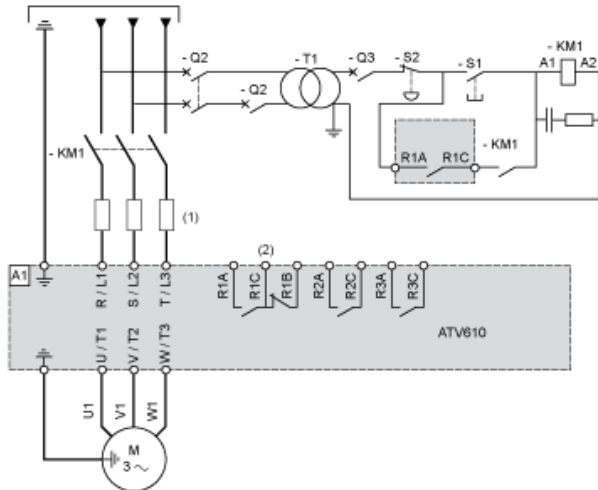

- (1) Line chokes
- (2) See control block wiring diagram
- A1 : Drive
- KM1 :Line Contactor
- Q2, Circuit breakers
- Q3 :
- S1, Pushbuttons
- S2 :
- T1 : Transformer for control part

## Control Block Wiring Diagram

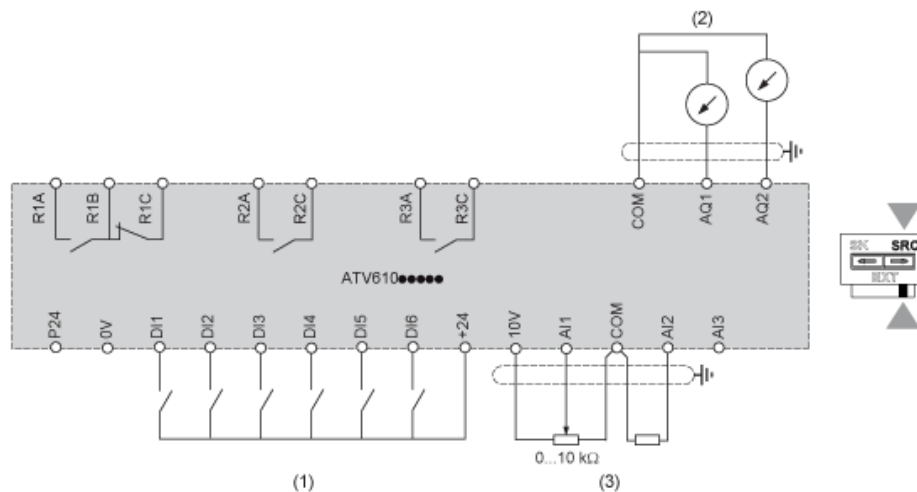

- (1) Digital Input
- (2) Analog Output
- (3) Analog Input
- R1A, Fault relay output
- R1B,
- R1C :
- R2A, Sequence relay output
- R2C :
- R3A, Sequence relay output
- R3C :



## Sensor Connection

It is possible to connect either 1 or 3 sensors on terminals AI2 or AI3.

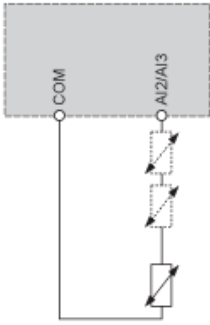

Derating Curves

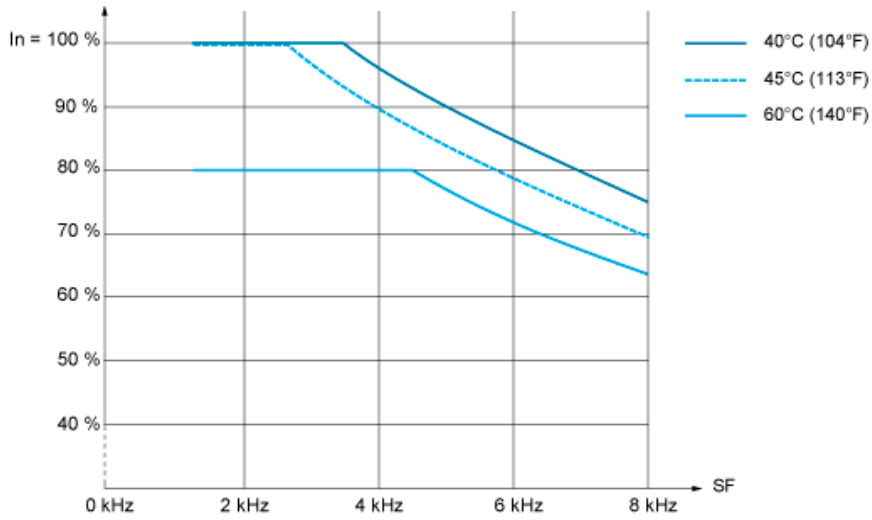

In : Nominal Drive Current  
SF : Switching Frequency